

Stormwater Report

Boxford, Massachusetts

Spofford Pond School

May 13, 2021

Revised: November 1, 2021

JOB NO: ENG20-0865

Weston & SampsonSM

Weston & Sampson
55 Walkers Brook Drive, Suite 100
Reading, MA 01867

www.westonandsampson.com
Tel: 978-532-1900 Fax: 978-977-0100

Table of Contents

Massachusetts DEP Stormwater Report Checklist

Stormwater Report Summary

Attachment A - Locus Map

Attachment B - NRCS Soils Map, Soils Report, and HSG Classifications

Attachment C - Test Pit Logs

Attachment D - Drainage Plans and HydroCAD Reports

Attachment E - Calculations

1. Pretreatment Volume Calculation
2. Standard #1 Velocity Calculations
3. TSS Removal Calcs
4. WQF Statement
5. Maine DEP Isolator Row Letter
6. StormTech Technical Memo
7. Isolator Row Sizing
8. Diversion Weir Calculation
9. Autodesk Storm and Sanitary Analysis Report

Attachment F - Long Term Pollution Prevention Plan

Attachment G - Construction Period Pollution and Erosion and Sedimentation
Control Plan

Attachment H - Operations & Maintenance Plan

Attachment I - Illicit Discharge Statement



Checklist for Stormwater Report

A. Introduction

Important: When filling out forms on the computer, use only the tab key to move your cursor - do not use the return key.



A Stormwater Report must be submitted with the Notice of Intent permit application to document compliance with the Stormwater Management Standards. The following checklist is NOT a substitute for the Stormwater Report (which should provide more substantive and detailed information) but is offered here as a tool to help the applicant organize their Stormwater Management documentation for their Report and for the reviewer to assess this information in a consistent format. As noted in the Checklist, the Stormwater Report must contain the engineering computations and supporting information set forth in Volume 3 of the [Massachusetts Stormwater Handbook](#). The Stormwater Report must be prepared and certified by a Registered Professional Engineer (RPE) licensed in the Commonwealth.

The Stormwater Report must include:

- The Stormwater Checklist completed and stamped by a Registered Professional Engineer (see page 2) that certifies that the Stormwater Report contains all required submittals.¹ This Checklist is to be used as the cover for the completed Stormwater Report.
- Applicant/Project Name
- Project Address
- Name of Firm and Registered Professional Engineer that prepared the Report
- Long-Term Pollution Prevention Plan required by Standards 4-6
- Construction Period Pollution Prevention and Erosion and Sedimentation Control Plan required by Standard 8²
- Operation and Maintenance Plan required by Standard 9

In addition to all plans and supporting information, the Stormwater Report must include a brief narrative describing stormwater management practices, including environmentally sensitive site design and LID techniques, along with a diagram depicting runoff through the proposed BMP treatment train. Plans are required to show existing and proposed conditions, identify all wetland resource areas, NRCS soil types, critical areas, Land Uses with Higher Potential Pollutant Loads (LUHPPL), and any areas on the site where infiltration rate is greater than 2.4 inches per hour. The Plans shall identify the drainage areas for both existing and proposed conditions at a scale that enables verification of supporting calculations.

As noted in the Checklist, the Stormwater Management Report shall document compliance with each of the Stormwater Management Standards as provided in the Massachusetts Stormwater Handbook. The soils evaluation and calculations shall be done using the methodologies set forth in Volume 3 of the Massachusetts Stormwater Handbook.

To ensure that the Stormwater Report is complete, applicants are required to fill in the Stormwater Report Checklist by checking the box to indicate that the specified information has been included in the Stormwater Report. If any of the information specified in the checklist has not been submitted, the applicant must provide an explanation. The completed Stormwater Report Checklist and Certification must be submitted with the Stormwater Report.

¹ The Stormwater Report may also include the Illicit Discharge Compliance Statement required by Standard 10. If not included in the Stormwater Report, the Illicit Discharge Compliance Statement must be submitted prior to the discharge of stormwater runoff to the post-construction best management practices.

² For some complex projects, it may not be possible to include the Construction Period Erosion and Sedimentation Control Plan in the Stormwater Report. In that event, the issuing authority has the discretion to issue an Order of Conditions that approves the project and includes a condition requiring the proponent to submit the Construction Period Erosion and Sedimentation Control Plan before commencing any land disturbance activity on the site.



Checklist for Stormwater Report

B. Stormwater Checklist and Certification

The following checklist is intended to serve as a guide for applicants as to the elements that ordinarily need to be addressed in a complete Stormwater Report. The checklist is also intended to provide conservation commissions and other reviewing authorities with a summary of the components necessary for a comprehensive Stormwater Report that addresses the ten Stormwater Standards.

Note: Because stormwater requirements vary from project to project, it is possible that a complete Stormwater Report may not include information on some of the subjects specified in the Checklist. If it is determined that a specific item does not apply to the project under review, please note that the item is not applicable (N.A.) and provide the reasons for that determination.

A complete checklist must include the Certification set forth below signed by the Registered Professional Engineer who prepared the Stormwater Report.

Registered Professional Engineer's Certification

I have reviewed the Stormwater Report, including the soil evaluation, computations, Long-term Pollution Prevention Plan, the Construction Period Erosion and Sedimentation Control Plan (if included), the Long-term Post-Construction Operation and Maintenance Plan, the Illicit Discharge Compliance Statement (if included) and the plans showing the stormwater management system, and have determined that they have been prepared in accordance with the requirements of the Stormwater Management Standards as further elaborated by the Massachusetts Stormwater Handbook. I have also determined that the information presented in the Stormwater Checklist is accurate and that the information presented in the Stormwater Report accurately reflects conditions at the site as of the date of this permit application.

Registered Professional Engineer Block and Signature



 11/1/2021
Signature and Date

Checklist

Project Type: Is the application for new development, redevelopment, or a mix of new and redevelopment?

- New development
- Redevelopment
- Mix of New Development and Redevelopment



Checklist for Stormwater Report

Checklist (continued)

LID Measures: Stormwater Standards require LID measures to be considered. Document what environmentally sensitive design and LID Techniques were considered during the planning and design of the project:

- No disturbance to any Wetland Resource Areas
- Site Design Practices (e.g. clustered development, reduced frontage setbacks)
- Reduced Impervious Area (Redevelopment Only)
- Minimizing disturbance to existing trees and shrubs
- LID Site Design Credit Requested:
 - Credit 1
 - Credit 2
 - Credit 3
- Use of "country drainage" versus curb and gutter conveyance and pipe
- Bioretention Cells (includes Rain Gardens)
- Constructed Stormwater Wetlands (includes Gravel Wetlands designs)
- Treebox Filter
- Water Quality Swale
- Grass Channel
- Green Roof
- Other (describe): Sediment Forebay

Standard 1: No New Untreated Discharges

- No new untreated discharges
- Outlets have been designed so there is no erosion or scour to wetlands and waters of the Commonwealth
- Supporting calculations specified in Volume 3 of the Massachusetts Stormwater Handbook included.



Checklist for Stormwater Report

Checklist (continued)

Standard 2: Peak Rate Attenuation

- Standard 2 waiver requested because the project is located in land subject to coastal storm flowage and stormwater discharge is to a wetland subject to coastal flooding.
- Evaluation provided to determine whether off-site flooding increases during the 100-year 24-hour storm.
- Calculations provided to show that post-development peak discharge rates do not exceed pre-development rates for the 2-year and 10-year 24-hour storms. If evaluation shows that off-site flooding increases during the 100-year 24-hour storm, calculations are also provided to show that post-development peak discharge rates do not exceed pre-development rates for the 100-year 24-hour storm.

Standard 3: Recharge

- Soil Analysis provided.
- Required Recharge Volume calculation provided.
- Required Recharge volume reduced through use of the LID site Design Credits.
- Sizing the infiltration, BMPs is based on the following method: Check the method used.
 - Static
 - Simple Dynamic
 - Dynamic Field¹
- Runoff from all impervious areas at the site discharging to the infiltration BMP.
- Runoff from all impervious areas at the site is *not* discharging to the infiltration BMP and calculations are provided showing that the drainage area contributing runoff to the infiltration BMPs is sufficient to generate the required recharge volume.
- Recharge BMPs have been sized to infiltrate the Required Recharge Volume.
- Recharge BMPs have been sized to infiltrate the Required Recharge Volume *only* to the maximum extent practicable for the following reason:
 - Site is comprised solely of C and D soils and/or bedrock at the land surface
 - M.G.L. c. 21E sites pursuant to 310 CMR 40.0000
 - Solid Waste Landfill pursuant to 310 CMR 19.000
 - Project is otherwise subject to Stormwater Management Standards only to the maximum extent practicable.
- Calculations showing that the infiltration BMPs will drain in 72 hours are provided.
- Property includes a M.G.L. c. 21E site or a solid waste landfill and a mounding analysis is included.

¹ 80% TSS removal is required prior to discharge to infiltration BMP if Dynamic Field method is used.



Checklist for Stormwater Report

Checklist (continued)

Standard 3: Recharge (continued)

- The infiltration BMP is used to attenuate peak flows during storms greater than or equal to the 10-year 24-hour storm and separation to seasonal high groundwater is less than 4 feet and a mounding analysis is provided.
- Documentation is provided showing that infiltration BMPs do not adversely impact nearby wetland resource areas.

Standard 4: Water Quality

The Long-Term Pollution Prevention Plan typically includes the following:

- Good housekeeping practices;
 - Provisions for storing materials and waste products inside or under cover;
 - Vehicle washing controls;
 - Requirements for routine inspections and maintenance of stormwater BMPs;
 - Spill prevention and response plans;
 - Provisions for maintenance of lawns, gardens, and other landscaped areas;
 - Requirements for storage and use of fertilizers, herbicides, and pesticides;
 - Pet waste management provisions;
 - Provisions for operation and management of septic systems;
 - Provisions for solid waste management;
 - Snow disposal and plowing plans relative to Wetland Resource Areas;
 - Winter Road Salt and/or Sand Use and Storage restrictions;
 - Street sweeping schedules;
 - Provisions for prevention of illicit discharges to the stormwater management system;
 - Documentation that Stormwater BMPs are designed to provide for shutdown and containment in the event of a spill or discharges to or near critical areas or from LUHPPL;
 - Training for staff or personnel involved with implementing Long-Term Pollution Prevention Plan;
 - List of Emergency contacts for implementing Long-Term Pollution Prevention Plan.
- A Long-Term Pollution Prevention Plan is attached to Stormwater Report and is included as an attachment to the Wetlands Notice of Intent.
 - Treatment BMPs subject to the 44% TSS removal pretreatment requirement and the one inch rule for calculating the water quality volume are included, and discharge:
 - is within the Zone II or Interim Wellhead Protection Area
 - is near or to other critical areas
 - is within soils with a rapid infiltration rate (greater than 2.4 inches per hour)
 - involves runoff from land uses with higher potential pollutant loads.
 - The Required Water Quality Volume is reduced through use of the LID site Design Credits.
 - Calculations documenting that the treatment train meets the 80% TSS removal requirement and, if applicable, the 44% TSS removal pretreatment requirement, are provided.



Checklist for Stormwater Report

Checklist (continued)

Standard 4: Water Quality (continued)

- The BMP is sized (and calculations provided) based on:
 - The ½" or 1" Water Quality Volume or
 - The equivalent flow rate associated with the Water Quality Volume and documentation is provided showing that the BMP treats the required water quality volume.
- The applicant proposes to use proprietary BMPs, and documentation supporting use of proprietary BMP and proposed TSS removal rate is provided. This documentation may be in the form of the propriety BMP checklist found in Volume 2, Chapter 4 of the Massachusetts Stormwater Handbook and submitting copies of the TARP Report, STEP Report, and/or other third party studies verifying performance of the proprietary BMPs.
- A TMDL exists that indicates a need to reduce pollutants other than TSS and documentation showing that the BMPs selected are consistent with the TMDL is provided.

Standard 5: Land Uses With Higher Potential Pollutant Loads (LUHPPLs)

- The NPDES Multi-Sector General Permit covers the land use and the Stormwater Pollution Prevention Plan (SWPPP) has been included with the Stormwater Report.
- The NPDES Multi-Sector General Permit covers the land use and the SWPPP will be submitted **prior to** the discharge of stormwater to the post-construction stormwater BMPs.
- The NPDES Multi-Sector General Permit does **not** cover the land use.
- LUHPPLs are located at the site and industry specific source control and pollution prevention measures have been proposed to reduce or eliminate the exposure of LUHPPLs to rain, snow, snow melt and runoff, and been included in the long term Pollution Prevention Plan.
- All exposure has been eliminated.
- All exposure has **not** been eliminated and all BMPs selected are on MassDEP LUHPPL list.
- The LUHPPL has the potential to generate runoff with moderate to higher concentrations of oil and grease (e.g. all parking lots with >1000 vehicle trips per day) and the treatment train includes an oil grit separator, a filtering bioretention area, a sand filter or equivalent.

Standard 6: Critical Areas

- The discharge is near or to a critical area and the treatment train includes only BMPs that MassDEP has approved for stormwater discharges to or near that particular class of critical area.
- Critical areas and BMPs are identified in the Stormwater Report.



Checklist for Stormwater Report

Checklist (continued)

Standard 7: Redevelopments and Other Projects Subject to the Standards only to the maximum extent practicable

- The project is subject to the Stormwater Management Standards only to the maximum Extent Practicable as a:
 - Limited Project
 - Small Residential Projects: 5-9 single family houses or 5-9 units in a multi-family development provided there is no discharge that may potentially affect a critical area.
 - Small Residential Projects: 2-4 single family houses or 2-4 units in a multi-family development with a discharge to a critical area
 - Marina and/or boatyard provided the hull painting, service and maintenance areas are protected from exposure to rain, snow, snow melt and runoff
 - Bike Path and/or Foot Path
- Redevelopment Project
- Redevelopment portion of mix of new and redevelopment.
- Certain standards are not fully met (Standard No. 1, 8, 9, and 10 must always be fully met) and an explanation of why these standards are not met is contained in the Stormwater Report.
- The project involves redevelopment and a description of all measures that have been taken to improve existing conditions is provided in the Stormwater Report. The redevelopment checklist found in Volume 2 Chapter 3 of the Massachusetts Stormwater Handbook may be used to document that the proposed stormwater management system (a) complies with Standards 2, 3 and the pretreatment and structural BMP requirements of Standards 4-6 to the maximum extent practicable and (b) improves existing conditions.

Standard 8: Construction Period Pollution Prevention and Erosion and Sedimentation Control

A Construction Period Pollution Prevention and Erosion and Sedimentation Control Plan must include the following information:

- Narrative;
 - Construction Period Operation and Maintenance Plan;
 - Names of Persons or Entity Responsible for Plan Compliance;
 - Construction Period Pollution Prevention Measures;
 - Erosion and Sedimentation Control Plan Drawings;
 - Detail drawings and specifications for erosion control BMPs, including sizing calculations;
 - Vegetation Planning;
 - Site Development Plan;
 - Construction Sequencing Plan;
 - Sequencing of Erosion and Sedimentation Controls;
 - Operation and Maintenance of Erosion and Sedimentation Controls;
 - Inspection Schedule;
 - Maintenance Schedule;
 - Inspection and Maintenance Log Form.
- A Construction Period Pollution Prevention and Erosion and Sedimentation Control Plan containing the information set forth above has been included in the Stormwater Report.



Checklist for Stormwater Report

Checklist (continued)

Standard 8: Construction Period Pollution Prevention and Erosion and Sedimentation Control (continued)

- The project is highly complex and information is included in the Stormwater Report that explains why it is not possible to submit the Construction Period Pollution Prevention and Erosion and Sedimentation Control Plan with the application. A Construction Period Pollution Prevention and Erosion and Sedimentation Control has **not** been included in the Stormwater Report but will be submitted **before** land disturbance begins.
- The project is **not** covered by a NPDES Construction General Permit.
- The project is covered by a NPDES Construction General Permit and a copy of the SWPPP is in the Stormwater Report.
- The project is covered by a NPDES Construction General Permit but no SWPPP been submitted. The SWPPP will be submitted BEFORE land disturbance begins.

Standard 9: Operation and Maintenance Plan

- The Post Construction Operation and Maintenance Plan is included in the Stormwater Report and includes the following information:
 - Name of the stormwater management system owners;
 - Party responsible for operation and maintenance;
 - Schedule for implementation of routine and non-routine maintenance tasks;
 - Plan showing the location of all stormwater BMPs maintenance access areas;
 - Description and delineation of public safety features;
 - Estimated operation and maintenance budget; and
 - Operation and Maintenance Log Form.
- The responsible party is **not** the owner of the parcel where the BMP is located and the Stormwater Report includes the following submissions:
 - A copy of the legal instrument (deed, homeowner's association, utility trust or other legal entity) that establishes the terms of and legal responsibility for the operation and maintenance of the project site stormwater BMPs;
 - A plan and easement deed that allows site access for the legal entity to operate and maintain BMP functions.

Standard 10: Prohibition of Illicit Discharges

- The Long-Term Pollution Prevention Plan includes measures to prevent illicit discharges;
- An Illicit Discharge Compliance Statement is attached;
- NO Illicit Discharge Compliance Statement is attached but will be submitted **prior to** the discharge of any stormwater to post-construction BMPs.

Stormwater Report

November 1, 2021

Applicant/Project Name: Town of Boxford
Spofford Pond School

Project Address: 31 Spofford Road, Boxford, MA

Application Prepared by:

Firm: Weston & Sampson, Inc.

Registered PE: James Pearson

Below is an explanation concerning Standards 1-10 as they apply to the Spofford Pond School project:

General:

The project applicant, the Town of Boxford, proposes a redevelopment project at the Spofford Pond School located at 31 Spofford Road in Boxford to improve site access and traffic circulation. Site work will include, but is not limited to grading, drainage, paving and landscaping. The site is actively used as an elementary school for the town of Boxford and will remain in use over the duration of the project. The site is predominantly developed, and the middle courtyard of the school contains a drinking water well, placing part of the site under Zone I well head protection with an approximate 250-FT protective radius. Existing topography is relatively moderate across the site, with elevations ranging from 140-FT at the northwestern portion of the site to a low of approximately 127-FT to the southeast, along the Spofford Pond existing drainage channel and headwall. NRCS soil mapping describes the site as being a mixture of Hinckley Loamy Sand (HSG-A) and Merrimac Fine Sandy Loam (HSG-A). Test pits conducted across the site generally support the soil mapping and can be found in Attachment C of this report.

Standard 1: No New Untreated Discharges

The proposed project will create no new untreated discharges. Total impervious area will be increased in comparison with existing conditions by approximately 9,945-SF. All discharges from new impervious area as well as a large portion of existing impervious, will undergo treatment via street sweeping, deep sump hooded catch basins, and underground stormtech chambers. Flows from the impervious areas southeast of the existing building will also receive pretreatment from a sediment forebay prior to discharge to the underground stormtech chambers. Additionally, subsurface detention chambers have been proposed to remove TSS from existing stormwater flows using proprietary treatment devices. As such, existing stormwater discharges will meet Standard 1 to the maximum extent practicable. HydroCAD modeling of the site is provided in Attachment D.

Standard 2: Peak Rate Attenuation

Existing and proposed conditions were modeled using HydroCAD computer software and Town of Boxford rainfall data. A table, summarizing peak discharges for the 2-Yr, 10-Yr, 25-Yr, 50-Yr and 100-Yr storm events can be found in Attachment D. The proposed design is such that peak runoff rates do not exceed pre-development rates, even in the 100-year storm scenario. Peak discharges will be managed by the underground stormtech chamber system.

Due to the prohibition associated with proposing stormwater recharge on this site (see standard 3), there will be a small increase in stormwater volumes leaving the site. This will result in negligible impact to the vernal pool downstream of the site. The increased stormwater volume during the 100-year storm is calculated as 12,436 cubic feet. The vernal pool is approximately 10,309 square feet in area, therefore the water surface in the vernal pool would theoretically increase by 1.2 feet as a result of the 100-year design storm. This increase will not result in downstream flooding and is therefore considered negligible.

To ensure that the work incorporates the performance standards recommended in the DEP's Stormwater Management Policy, necessary erosion and sedimentation control measures will be utilized during construction, as depicted on the site plans.

Standard 3: Recharge

As a redevelopment, Standard 3 shall be met to the maximum extent practicable. However, due to the proximity of the site to a landfill and the known presence of arsenic in the onsite drinking water well, stormwater recharge practices are not recommended for this site. Supporting documentation from the project LSP is provided to further support this conclusion.

Standard 4: Water Quality

Standard 4 shall be met to the maximum extent practicable. Treatment practices have been designed to capture the required water quality volume and provide treatment to remove greater than 80% of total suspended solids. The proposed stormwater management system will present an improvement over existing conditions.

During the project, appropriate BMPs will be used to minimize sedimentation and soil erosion.

Standard 5: Land Uses with Higher Potential Pollutant Loads (LUHPPLs)

This site is not considered a LUHPPL, as such, Standard 5 does not apply.

Standard 6: Critical Areas

Discharges will occur within a Zone II of a wellhead protection area. See Figure 4 of the Notice of Intent Application, entitled Environmental Resources Map. A NHSP certified vernal pool is located within the wetlands where the proposed drainage network discharges through a drainage channel. The project does not propose to discharge any untreated runoff to this area.

Standard 7: Redevelopments and Other Projects Subject to the Standards Only to the Maximum Extent Practicable

This is a redevelopment project. Stormwater standards 1, 2, 3 and 4 have been met to the maximum extent practicable.

Standard 8: Construction Period Pollution Prevention and Erosion and Sediment Control

A detailed Construction Period Pollution Prevention and Erosion and Sedimentation Control Plan is included in Attachment G. To ensure that the work incorporates the performance standards recommended in the DEP's Stormwater Management Policy, necessary erosion and sedimentation control measures will be utilized during construction.

Standard 9: Operation and Maintenance Plan

An operations and maintenance plan is included in Attachment H.

Standard 10: Prohibition of Illicit Discharges

An illicit discharge compliance statement has been included in Attachment I.

Registered Professional Engineer's Certification

I have reviewed the Stormwater Report, including any relevant soil evaluations, computations, Long-term Pollution Prevention Plan, the Construction Period Erosion and Sedimentation Control Plan, the Long-term Post-Construction Operation and Maintenance Plan, the Illicit Discharge Compliance Statement and the plans showing the stormwater management system, and have determined that they have been prepared in accordance with the requirements of the Stormwater Management Standards as further elaborated by the Massachusetts Stormwater Handbook. I have also determined that the information presented in the Stormwater Checklist is accurate and that the information presented in the Stormwater Report accurately reflects conditions at the site as of the date of this permit application.

Registered Professional Engineer Block and Signature

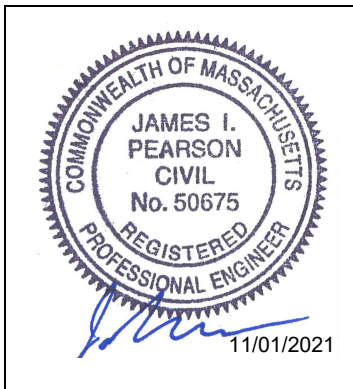



Signature and Date

11/1/2021

Attachment A - Locus Map

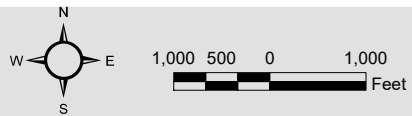

Copyright © 2013 National Geographic Society, i-cubed



Data Source: Office of Geographic and Environmental Information (MassGIS), Commonwealth of Massachusetts Executive Office of Environmental Affairs

Legend
 Site Location

Attachment A
Locus Map
Spofford Pond School
USGS Topographic Map



**Attachment B - NRCS Soils Map, Soils Report, and HSG
Classifications**

Hydrologic Soil Group—Essex County, Massachusetts, Northern Part



Soil Map may not be valid at this scale.

Map Scale: 1:2,150 if printed on A landscape (11" x 8.5") sheet.

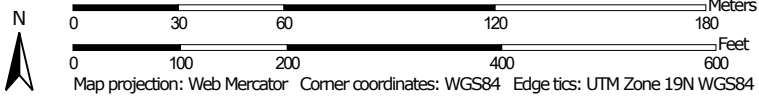

MAP LEGEND

Area of Interest (AOI)









 Area of Interest (AOI)

Soils

Soil Rating Polygons





 A
 A/D
 B
 B/D
 C
 C/D
 D
 Not rated or not available

Soil Rating Lines

 A
 A/D
 B
 B/D
 C
 C/D
 D
 Not rated or not available

Soil Rating Points





 A
 A/D
 B
 B/D

 C
 C/D
 D
 Not rated or not available

Water Features

 Streams and Canals

Transportation

 Rails
 Interstate Highways
 US Routes
 Major Roads
 Local Roads

Background

 Aerial Photography

MAP INFORMATION

The soil surveys that comprise your AOI were mapped at 1:15,800.

Warning: Soil Map may not be valid at this scale.

Enlargement of maps beyond the scale of mapping can cause misunderstanding of the detail of mapping and accuracy of soil line placement. The maps do not show the small areas of contrasting soils that could have been shown at a more detailed scale.

Please rely on the bar scale on each map sheet for map measurements.

Source of Map: Natural Resources Conservation Service
 Web Soil Survey URL:
 Coordinate System: Web Mercator (EPSG:3857)

Maps from the Web Soil Survey are based on the Web Mercator projection, which preserves direction and shape but distorts distance and area. A projection that preserves area, such as the Albers equal-area conic projection, should be used if more accurate calculations of distance or area are required.

This product is generated from the USDA-NRCS certified data as of the version date(s) listed below.

Soil Survey Area: Essex County, Massachusetts, Northern Part
 Survey Area Data: Version 16, Jun 9, 2020

Soil map units are labeled (as space allows) for map scales 1:50,000 or larger.

Date(s) aerial images were photographed: Sep 13, 2019—Oct 5, 2019

The orthophoto or other base map on which the soil lines were compiled and digitized probably differs from the background imagery displayed on these maps. As a result, some minor shifting of map unit boundaries may be evident.

Hydrologic Soil Group

Map unit symbol	Map unit name	Rating	Acres in AOI	Percent of AOI
253C	Hinckley loamy sand, 8 to 15 percent slopes	A	9.4	74.7%
254B	Merrimac fine sandy loam, 3 to 8 percent slopes	A	3.2	25.3%
Totals for Area of Interest			12.6	100.0%

Description

Hydrologic soil groups are based on estimates of runoff potential. Soils are assigned to one of four groups according to the rate of water infiltration when the soils are not protected by vegetation, are thoroughly wet, and receive precipitation from long-duration storms.

The soils in the United States are assigned to four groups (A, B, C, and D) and three dual classes (A/D, B/D, and C/D). The groups are defined as follows:

Group A. Soils having a high infiltration rate (low runoff potential) when thoroughly wet. These consist mainly of deep, well drained to excessively drained sands or gravelly sands. These soils have a high rate of water transmission.

Group B. Soils having a moderate infiltration rate when thoroughly wet. These consist chiefly of moderately deep or deep, moderately well drained or well drained soils that have moderately fine texture to moderately coarse texture. These soils have a moderate rate of water transmission.

Group C. Soils having a slow infiltration rate when thoroughly wet. These consist chiefly of soils having a layer that impedes the downward movement of water or soils of moderately fine texture or fine texture. These soils have a slow rate of water transmission.

Group D. Soils having a very slow infiltration rate (high runoff potential) when thoroughly wet. These consist chiefly of clays that have a high shrink-swell potential, soils that have a high water table, soils that have a claypan or clay layer at or near the surface, and soils that are shallow over nearly impervious material. These soils have a very slow rate of water transmission.

If a soil is assigned to a dual hydrologic group (A/D, B/D, or C/D), the first letter is for drained areas and the second is for undrained areas. Only the soils that in their natural condition are in group D are assigned to dual classes.

Rating Options

Aggregation Method: Dominant Condition

Component Percent Cutoff: None Specified

Tie-break Rule: Higher

Attachment C - Test Pit Logs

M E M O R A N D U M

TO: James Pearson
FROM: Kyle Elmy
DATE: January 21, 2021
SUBJECT: Spofford Pond School, Boxford, MA – Test pit results

Test pits were conducted on January 19th, 2021, at the Spofford Pond School in Boxford, MA. The test pits were performed to better understand the subsurface soil and drainage conditions, so that proper precautions could be accounted for during the reconstruction of the school parking lots and landscaping. The following is a summary of the test pit explorations. Detailed test pit logs and photos are attached to this memorandum. The soil was evaluated by Kyle Elmy, of Weston & Sampson, a licensed soil evaluator in MA, SE14274.

Eight (8) test pits were performed on site. Please refer to the attached site plan for exact locations of the test pits. The test pits were excavated to a depth of 6-ft to 8-ft below ground surface (b.g.s.). Test pits were stopped when the required depths were reached or pit stability could not be maintained and further exploration could not be achieved. Test pits throughout the site were consistent and contained mostly sandy loam and sand with a notable amount of gravel and cobbles.

Screening for contaminated soils was conducted in conjunction with the test pits. A Photoionization Detector (PID) was used to analyze the soils within the pit. Samples were taken at 2-ft intervals and tested using the jar headspace method. No contaminants were encountered within any of the test pits.

With respect to the site, test pit 1 was located behind the school at the Northwest end of the pavement where, the pavement met the grass. Test pit 1 ranged from fill to sandy loam to sand, with a massive structure. The test pit was stopped at a depth of 93-in b.g.s., due to pit stability. No sample was taken and no redox was encountered. Irrigation piping was discovered, at 3-in b.g.s.

Test pit 2 was to the Southeast of test pit 1, in a reclaimed asphalt overflow parking lot, to the Southeast of the school. Test pit 2 ranged from pavement to sandy loam to sand, with a massive structure. The test pit was stopped at a depth of 72-in b.g.s., due to pit stability. No sample was taken and no redox was encountered.

Test pit 3 was located along the entrance to the parking lot, to the South of test pit 2, and to the Southeast of the school and parking lot. Test pit 3 ranged from pavement to fill to sandy loam to sand, with a massive structure. The test pit was stopped at a depth of 90-in b.g.s., due to pit stability. No sample was taken and no redox was encountered. A PVC pipe was encountered at 54-in b.g.s. The pipe size was not able to be determined, but it is believed to be for storm drainage.

Test pit 4 was located at the Southwest of test pit 3 in a median within the parking lot. Test pit 4 ranged from fill to sand, with a massive structure. The test pit was stopped at a depth of 92-in b.g.s., due to pit stability. No sample was taken and no redox was encountered. As digging began two (2) small concrete blocks were encountered at 12-in b.g.s., no other debris was encountered in the fill.

Test pit 5 was to the Southwest of test pit 4, and to the west of the parking lot entryway. Test pit 5 ranged from fill to sandy loam to sand, with a massive structure. The test pit was stopped at a depth of 84-in b.g.s., due to pit stability. Redox features were not encountered at this location and no sample was taken.

Test pit 6 was to the Southwest of test pit 5, and centered in the grassy area in front of the front parking lot. Test pit 6 ranged from sandy loam to sand, with a massive structure. The test pit was stopped at a depth of 92-in, b.g.s., due to pit stability. Redox features were not encountered at this location and no sample was taken.

Test pit 7 was located to the Northwest of test pit 6, along the wooded area to the south west of the school. Test pit 7 ranged from fill to sandy loam to sand, with a massive structure. The test pit was stopped at a depth of 96-in, b.g.s., due to pit stability. Redox features were not encountered at this location and no sample was taken.

Test pit 8 was located to the Northeast of test pit 7 along the western side of the school within a parking lot median. Test pit 8 ranged from fill to sandy loam to sand, with a massive structure. The test pit was stopped at a depth of 96-in, b.g.s., due to pit stability. Redox features were not encountered at this location and no sample was taken.

The USDA web soil survey indicates that at this site the following soils are present; map unit 253C Hinckley loamy sand and 254B Merrimac fine sandy loam. The USGS surficial geologic map indicates that in this particular location coarse deposits consisting of gravel and sand are present. The test pit data gathered at the Spofford Pond School is consistent with the data recorded on both the USDA and USGS websites. Please refer to the attached maps and test pit results for more information and soil layer ranges.

TEST PIT LOG			
PROJECT NAME/NO.	Spofford Pond School - ENG20-0865	TEST PIT NUMBER	
LOCATION	Spofford Pond School, Boxford, MA	TP 1	
CLIENT	Boxford, MA	GROUND SURFACE	
CONTRACTOR	RE Thompson	FOREMAN:	see plan
OBSERVED BY	K. Elmy	DATE	1/19/21
CHECKED BY		DATE	
		DEPTH TO GROUNDWATER BELOW SURFACE	
		Not Observed	
DEPTH BELOW GROUND SURFACE (in.)	TEST PIT DIAGRAM AND SOIL DESCRIPTION		
19"	Fill 10% Gravel & 10% Cobbles		
24"	Ap - Dark Brown Sandy Loam (10YR 3/3) 10% Gravel & 10% Cobbles		
29"	Bw - Brown Sandy Loam (10YR 4/3) 10% Gravel & 10% Cobbles		
93"	C1 - Yellowish Brown Coarse Sand (10YR 5/4) 5% Gravel		
	- End of Exploration -		
NOTES:		TEST PIT NUMBER	
1. No Redox encountered		TP 1	
2. PID = 0.0PPM		WESTON & SAMPSON	
3. Irrigation line encountered at 3-in		ENGINEERS, INC.	

TEST PIT LOG

PROJECT NAME/NO.	Spofford Pond School - ENG20-0865		TEST PIT NUMBER TP 1
LOCATION	Spofford Pond School, Boxford, MA		
CLIENT	Boxford, MA		GROUND SURFACE
CONTRACTOR	RE Thompson	FOREMAN:	ELEVATION <u>see plan</u>
OBSERVED BY	K. Elmy	DATE	1/19/21
CHECKED BY		DATE	
			DEPTH TO GROUNDWATER BELOW SURFACE <u>Not Observed</u>

DEPTH BELOW GROUND SURFACE (in.)	TEST PIT DIAGRAM AND SOIL DESCRIPTION
----------------------------------	---------------------------------------



NOTES:

1. No Redox encountered
2. PID = 0.0PPM
3. Irrigation line encountered at 3-in

TEST PIT NUMBER
TP 1

WESTON & SAMPSON
ENGINEERS, INC.

TEST PIT LOG

PROJECT NAME/NO.	<u>Spofford Pond School - ENG20-0865</u>	TEST PIT NUMBER	
LOCATION	<u>Spofford Pond School, Boxford, MA</u>	TP 2	
CLIENT	<u>Boxford, MA</u>	GROUND SURFACE	
CONTRACTOR	<u>RE Thompson</u>	FOREMAN:	<u>see plan</u>
OBSERVED BY	<u>K. Elmy</u>	DATE	<u>1/19/21</u>
CHECKED BY	_____	DATE	_____
		DEPTH TO GROUNDWATER BELOW SURFACE <u>Not Observed</u>	

DEPTH BELOW GROUND SURFACE (in.)	TEST PIT DIAGRAM AND SOIL DESCRIPTION
4"	Pavement
8"	Bw - Yellowish Brown Sandy Loam (10YR 5/6) 10% Gravel & 10% Cobbles
24"	C1 - Brown Sand (10YR 5/3) 10% Gravel & 5% Cobbles
72"	C2 - Pale Brown Coarse Sand (10YR 6/3) 5% Gravel & 5% Cobbles
	- End of Exploration -

NOTES: 1. No Redox encountered 2. PID = 0.0PPM	TEST PIT NUMBER
	TP 2
	WESTON & SAMPSON ENGINEERS, INC.

TEST PIT LOG

PROJECT NAME/NO.	Spofford Pond School - ENG20-0865		TEST PIT NUMBER TP 2
LOCATION	Spofford Pond School, Boxford, MA		
CLIENT	Boxford, MA		GROUND SURFACE
CONTRACTOR	RE Thompson	FOREMAN:	ELEVATION <u>see plan</u>
OBSERVED BY	K. Elmy	DATE	1/19/21
CHECKED BY		DATE	
			DEPTH TO GROUNDWATER BELOW SURFACE <u>Not Observed</u>

DEPTH BELOW
GROUND
SURFACE (in.)

TEST PIT DIAGRAM AND SOIL DESCRIPTION



NOTES:

1. No Redox encountered
2. PID = 0.0PPM

TEST PIT NUMBER

TP 2

**WESTON & SAMPSON
ENGINEERS, INC.**

TEST PIT LOG

PROJECT NAME/NO.	<u>Spofford Pond School - ENG20-0865</u>	TEST PIT NUMBER	
LOCATION	<u>Spofford Pond School, Boxford, MA</u>	TP 3	
CLIENT	<u>Boxford, MA</u>	GROUND SURFACE	
CONTRACTOR	<u>RE Thompson</u>	FOREMAN:	<u>see plan</u>
OBSERVED BY	<u>K. Elmy</u>	DATE	<u>1/19/21</u>
CHECKED BY	_____	DATE	_____
		DEPTH TO GROUNDWATER BELOW SURFACE <u>Not Observed</u>	

DEPTH BELOW GROUND SURFACE (in.)	TEST PIT DIAGRAM AND SOIL DESCRIPTION
4"	Pavement
21"	Fill
24"	Ab - Dark Brown Sandy Loam (10YR 3/3) 10% Gravel & 10% Cobbles
32"	Bw - Brown Sandy Loam (10YR 5/3) 10% Gravel & 10% Cobbles
90"	C1 - Dark Yellowish Brown Coarse Sand (10YR 4/4) 5% Gravel & 5% Cobbles
	- End of Exploration -

NOTES: 1. No Redox encountered 2. PID = 0.0PPM 3. PVC pipe encountered at 54-in	TEST PIT NUMBER
	TP 3
	WESTON & SAMPSON ENGINEERS, INC.

TEST PIT LOG

PROJECT NAME/NO.	Spofford Pond School - ENG20-0865		TEST PIT NUMBER TP 3
LOCATION	Spofford Pond School, Boxford, MA		
CLIENT	Boxford, MA		GROUND SURFACE
CONTRACTOR	RE Thompson	FOREMAN:	ELEVATION <u>see plan</u>
OBSERVED BY	K. Elmy	DATE	1/19/21
CHECKED BY		DATE	
			DEPTH TO GROUNDWATER BELOW SURFACE <u>Not Observed</u>

DEPTH BELOW GROUND SURFACE (in.)	TEST PIT DIAGRAM AND SOIL DESCRIPTION
----------------------------------	---------------------------------------



NOTES: 1. No Redox encountered 2. PID = 0.0PPM 3. PVC pipe encountered at 54-in	TEST PIT NUMBER TP 3
	WESTON & SAMPSON ENGINEERS, INC.

TEST PIT LOG

PROJECT NAME/NO.	<u>Spofford Pond School - ENG20-0865</u>	TEST PIT NUMBER	
LOCATION	<u>Spofford Pond School, Boxford, MA</u>	TP 4	
CLIENT	<u>Boxford, MA</u>	GROUND SURFACE	
CONTRACTOR	<u>RE Thompson</u>	FOREMAN:	<u>see plan</u>
OBSERVED BY	<u>K. Elmy</u>	DATE	<u>1/19/21</u>
CHECKED BY	_____	DATE	_____
		DEPTH TO GROUNDWATER BELOW SURFACE <u>Not Observed</u>	

DEPTH BELOW GROUND SURFACE (in.)	TEST PIT DIAGRAM AND SOIL DESCRIPTION
28"	Fill
92"	C1 - Yellowish Brown Coarse Sand (10YR 5/4) 5% Gravel & 5% Cobbles
	- End of Exploration -

NOTES: 1. No Redox encountered 2. PID = 0.0PPM	TEST PIT NUMBER TP 4
	WESTON & SAMPSON ENGINEERS, INC.

TEST PIT LOG

PROJECT NAME/NO.	Spofford Pond School - ENG20-0865		TEST PIT NUMBER TP 4
LOCATION	Spofford Pond School, Boxford, MA		
CLIENT	Boxford, MA		GROUND SURFACE
CONTRACTOR	RE Thompson	FOREMAN:	ELEVATION <u>see plan</u>
OBSERVED BY	K. Elmy	DATE	1/19/21
CHECKED BY		DATE	
			DEPTH TO GROUNDWATER BELOW SURFACE <u>Not Observed</u>

DEPTH BELOW
GROUND
SURFACE (in.)

TEST PIT DIAGRAM AND SOIL DESCRIPTION



NOTES:

1. No Redox encountered
2. PID = 0.0PPM

TEST PIT NUMBER

TP 4

**WESTON & SAMPSON
ENGINEERS, INC.**

TEST PIT LOG			
PROJECT NAME/NO.	Spofford Pond School - ENG20-0865		TEST PIT NUMBER TP 5
LOCATION	Spofford Pond School, Boxford, MA		
CLIENT	Boxford, MA		GROUND SURFACE
CONTRACTOR	RE Thompson	FOREMAN:	ELEVATION
OBSERVED BY	K. Elmy	DATE	1/19/21
CHECKED BY		DATE	
			DEPTH TO GROUNDWATER BELOW SURFACE
			Not Observed
DEPTH BELOW GROUND SURFACE (in.)	TEST PIT DIAGRAM AND SOIL DESCRIPTION		
12"	Fill 10% Gravel & 10% Cobbles		
16"	Ab - Dark Grayish Brown Sandy Loam (10YR 4/2) 10% Gravel & 10% Cobbles		
20"	Bw - Yellowish Brown Sandy Loam (10YR 5/8) 10% Gravel & 10% Cobbles		
84"	C1 - Yellowish Brown Coarse Sand (10YR 5/4) 5% Gravel & 5% Cobbles		
	- End of Exploration -		
NOTES: 1. No Redox encountered 2. PID = 0.0PPM		TEST PIT NUMBER TP 5	
		WESTON & SAMPSON ENGINEERS, INC.	

TEST PIT LOG

PROJECT NAME/NO.	Spofford Pond School - ENG20-0865		TEST PIT NUMBER TP 5
LOCATION	Spofford Pond School, Boxford, MA		
CLIENT	Boxford, MA		GROUND SURFACE
CONTRACTOR	RE Thompson	FOREMAN:	ELEVATION <u>see plan</u>
OBSERVED BY	K. Elmy	DATE	1/19/21
CHECKED BY		DATE	
			DEPTH TO GROUNDWATER BELOW SURFACE <u>Not Observed</u>

DEPTH BELOW GROUND SURFACE (in.)	TEST PIT DIAGRAM AND SOIL DESCRIPTION
----------------------------------	---------------------------------------



NOTES:

1. No Redox encountered
2. PID = 0.0PPM

TEST PIT NUMBER
TP 5

WESTON & SAMPSON
ENGINEERS, INC.

TEST PIT LOG

PROJECT NAME/NO.	<u>Spofford Pond School - ENG20-0865</u>	TEST PIT NUMBER	
LOCATION	<u>Spofford Pond School, Boxford, MA</u>	TP 6	
CLIENT	<u>Boxford, MA</u>	GROUND SURFACE	
CONTRACTOR	<u>RE Thompson</u>	FOREMAN:	<u>see plan</u>
OBSERVED BY	<u>K. Elmy</u>	DATE	<u>1/19/21</u>
CHECKED BY	_____	DATE	_____
		DEPTH TO GROUNDWATER BELOW SURFACE <u>Not Observed</u>	

DEPTH BELOW GROUND SURFACE (in.)	TEST PIT DIAGRAM AND SOIL DESCRIPTION
12"	Ap - Dark Brown Sandy Loam (10YR 3/3) 10% Gravel & 10% Cobbles
24"	Bw - Yellowish Brown Sandy Loam (10YR 5/6) 10% Gravel & 10% Cobbles
92"	C1 - Brown Coarse Sand (10YR 5/3) 5% Gravel & 5% Cobbles
	- End of Exploration -

NOTES: 1. No Redox encountered 2. PID = 0.0PPM	TEST PIT NUMBER
	TP 6
	WESTON & SAMPSON ENGINEERS, INC.

TEST PIT LOG

PROJECT NAME/NO.	Spofford Pond School - ENG20-0865		TEST PIT NUMBER TP 6
LOCATION	Spofford Pond School, Boxford, MA		
CLIENT	Boxford, MA		GROUND SURFACE
CONTRACTOR	RE Thompson	FOREMAN:	ELEVATION see plan
OBSERVED BY	K. Elmy	DATE	1/19/21
CHECKED BY		DATE	
			DEPTH TO GROUNDWATER BELOW SURFACE Not Observed

DEPTH BELOW
GROUND
SURFACE (in.)

TEST PIT DIAGRAM AND SOIL DESCRIPTION



NOTES:

1. No Redox encountered
2. PID = 0.0PPM

TEST PIT NUMBER

TP 6

**WESTON & SAMPSON
ENGINEERS, INC.**

TEST PIT LOG

PROJECT NAME/NO.	<u>Spofford Pond School - ENG20-0865</u>	TEST PIT NUMBER TP 7
LOCATION	<u>Spofford Pond School, Boxford, MA</u>	
CLIENT	<u>Boxford, MA</u>	GROUND SURFACE
CONTRACTOR	<u>RE Thompson</u> FOREMAN: _____	ELEVATION <u>see plan</u>
OBSERVED BY	<u>K. Elmy</u> DATE <u>1/19/21</u>	DEPTH TO GROUNDWATER BELOW
CHECKED BY	_____ DATE _____	SURFACE <u>Not Observed</u>

DEPTH BELOW GROUND SURFACE (in.)	TEST PIT DIAGRAM AND SOIL DESCRIPTION
12"	Fill
24"	Ap - Dark Brown Sandy Loam (10YR 3/3) 10% Gravel & 10% Cobbles
36"	Bw - Yellowish Brown Sandy Loam (10YR 5/6) 10% Gravel & 10% Cobbles
96"	C1 - Brown Coarse Sand (10YR 5/4) 5% Gravel & 5% Cobbles
	- End of Exploration -

NOTES: 1. No Redox encountered 2. PID = 0.0PPM	TEST PIT NUMBER TP 7
	WESTON & SAMPSON ENGINEERS, INC.

TEST PIT LOG

PROJECT NAME/NO.	Spofford Pond School - ENG20-0865		TEST PIT NUMBER TP 7
LOCATION	Spofford Pond School, Boxford, MA		
CLIENT	Boxford, MA		GROUND SURFACE
CONTRACTOR	RE Thompson	FOREMAN:	ELEVATION <u>see plan</u>
OBSERVED BY	K. Elmy	DATE	1/19/21
CHECKED BY		DATE	
			DEPTH TO GROUNDWATER BELOW SURFACE <u>Not Observed</u>

DEPTH BELOW GROUND SURFACE (in.)	TEST PIT DIAGRAM AND SOIL DESCRIPTION
----------------------------------	---------------------------------------

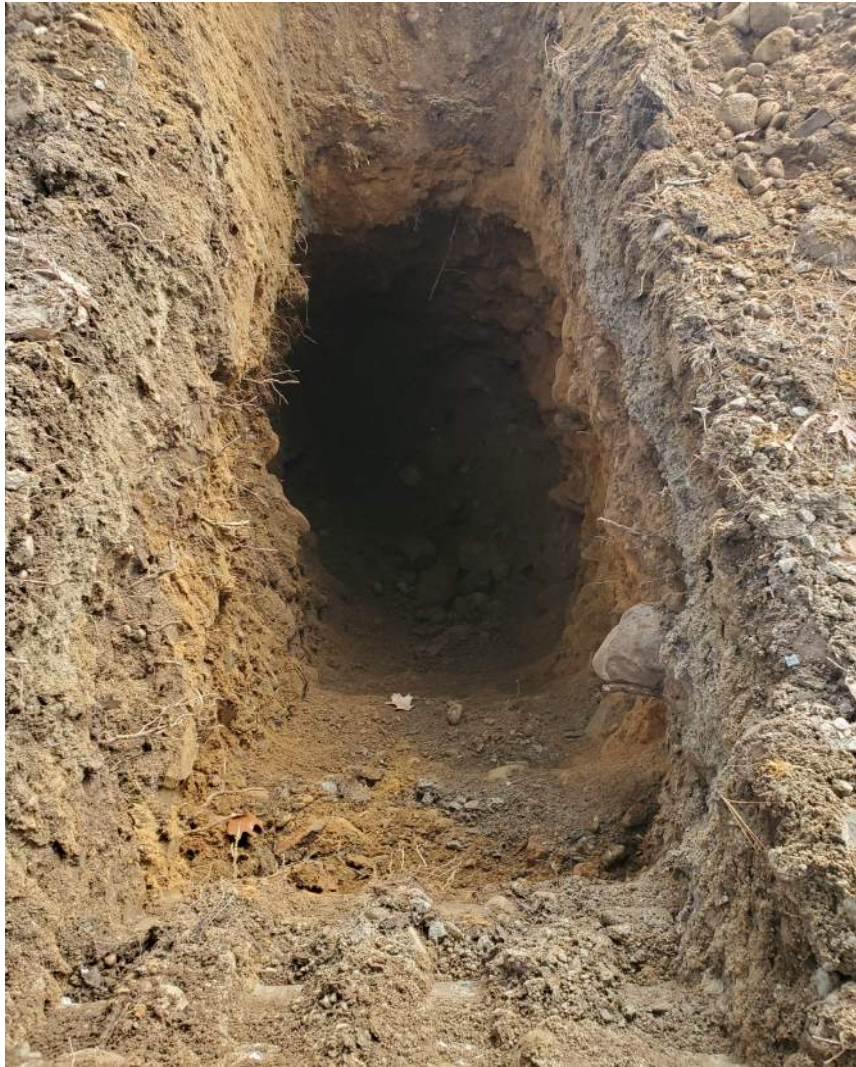

NOTES:

1. No Redox encountered
2. PID = 0.0PPM

TEST PIT NUMBER
TP 7

WESTON & SAMPSON
ENGINEERS, INC.

TEST PIT LOG

PROJECT NAME/NO.	<u>Spofford Pond School - ENG20-0865</u>	TEST PIT NUMBER	TP 8
LOCATION	<u>Spofford Pond School, Boxford, MA</u>	GROUND SURFACE	
CLIENT	<u>Boxford, MA</u>	ELEVATION	<u>see plan</u>
CONTRACTOR	<u>RE Thompson</u>	FOREMAN:	<u></u>
OBSERVED BY	<u>K. Elmy</u>	DATE	<u>1/19/21</u>
CHECKED BY	<u></u>	DATE	<u></u>
		DEPTH TO GROUNDWATER BELOW SURFACE	<u>Not Observed</u>

DEPTH BELOW GROUND SURFACE (in.)	TEST PIT DIAGRAM AND SOIL DESCRIPTION
23"	Fill
26"	Ap - Dark Brown Sandy Loam (10YR 3/3) 10% Gravel & 10% Cobbles
28"	Bw - Brown Sandy Loam (10YR 4/3) 10% Gravel & 10% Cobbles
96"	C1 - Brown Coarse Sand (10YR 5/4) 5% Gravel & 5% Cobbles
	- End of Exploration -

NOTES: 1. No Redox encountered 2. PID = 0.0PPM	TEST PIT NUMBER TP 8
	WESTON & SAMPSON ENGINEERS, INC.

TEST PIT LOG

PROJECT NAME/NO.	Spofford Pond School - ENG20-0865		TEST PIT NUMBER TP 8
LOCATION	Spofford Pond School, Boxford, MA		
CLIENT	Boxford, MA		GROUND SURFACE
CONTRACTOR	RE Thompson	FOREMAN:	ELEVATION <u>see plan</u>
OBSERVED BY	K. Elmy	DATE	1/19/21
CHECKED BY		DATE	
			DEPTH TO GROUNDWATER BELOW SURFACE <u>Not Observed</u>

DEPTH BELOW GROUND SURFACE (in.)	TEST PIT DIAGRAM AND SOIL DESCRIPTION
----------------------------------	---------------------------------------



NOTES:

1. No Redox encountered
2. PID = 0.0PPM

TEST PIT NUMBER TP 8
WESTON & SAMPSON ENGINEERS, INC.

Soil Map—Essex County, Massachusetts, Northern Part
(Spofford Pond School)



Map Scale: 1:3,400 if printed on A landscape (11" x 8.5") sheet.

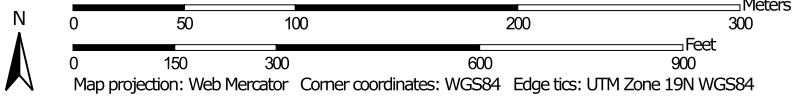

Soil Map—Essex County, Massachusetts, Northern Part
(Spofford Pond School)

MAP LEGEND

Area of Interest (AOI)

 Area of Interest (AOI)



















Soils





 Soil Map Unit Polygons

 Soil Map Unit Lines

 Soil Map Unit Points

Special Point Features

-  Blowout
-  Borrow Pit
-  Clay Spot
-  Closed Depression
-  Gravel Pit
-  Gravelly Spot
-  Landfill
-  Lava Flow
-  Marsh or swamp
-  Mine or Quarry
-  Miscellaneous Water
-  Perennial Water
-  Rock Outcrop
-  Saline Spot
-  Sandy Spot
-  Severely Eroded Spot
-  Sinkhole
-  Slide or Slip
-  Sodic Spot

-  Spoil Area
-  Stony Spot
-  Very Stony Spot
-  Wet Spot
-  Other
-  Special Line Features

Water Features

 Streams and Canals

Transportation

-  Rails
-  Interstate Highways
-  US Routes
-  Major Roads
-  Local Roads

Background

 Aerial Photography

MAP INFORMATION

The soil surveys that comprise your AOI were mapped at 1:15,800.

Warning: Soil Map may not be valid at this scale.

Enlargement of maps beyond the scale of mapping can cause misunderstanding of the detail of mapping and accuracy of soil line placement. The maps do not show the small areas of contrasting soils that could have been shown at a more detailed scale.

Please rely on the bar scale on each map sheet for map measurements.

Source of Map: Natural Resources Conservation Service
Web Soil Survey URL:
Coordinate System: Web Mercator (EPSG:3857)

Maps from the Web Soil Survey are based on the Web Mercator projection, which preserves direction and shape but distorts distance and area. A projection that preserves area, such as the Albers equal-area conic projection, should be used if more accurate calculations of distance or area are required.

This product is generated from the USDA-NRCS certified data as of the version date(s) listed below.

Soil Survey Area: Essex County, Massachusetts, Northern Part
Survey Area Data: Version 16, Jun 9, 2020

Soil map units are labeled (as space allows) for map scales 1:50,000 or larger.

Date(s) aerial images were photographed: Sep 13, 2019—Oct 5, 2019

The orthophoto or other base map on which the soil lines were compiled and digitized probably differs from the background imagery displayed on these maps. As a result, some minor shifting of map unit boundaries may be evident.

Map Unit Legend

Map Unit Symbol	Map Unit Name	Acres in AOI	Percent of AOI
1	Water	1.9	6.6%
32B	Wareham loamy sand, 3 to 8 percent slopes	0.5	1.9%
52A	Freetown muck, 0 to 1 percent slopes	1.1	3.6%
253A	Hinckley loamy sand, 0 to 3 percent slopes	3.5	11.9%
253C	Hinckley loamy sand, 8 to 15 percent slopes	17.0	58.1%
254B	Merrimac fine sandy loam, 3 to 8 percent slopes	5.2	17.9%
Totals for Area of Interest		29.2	100.0%

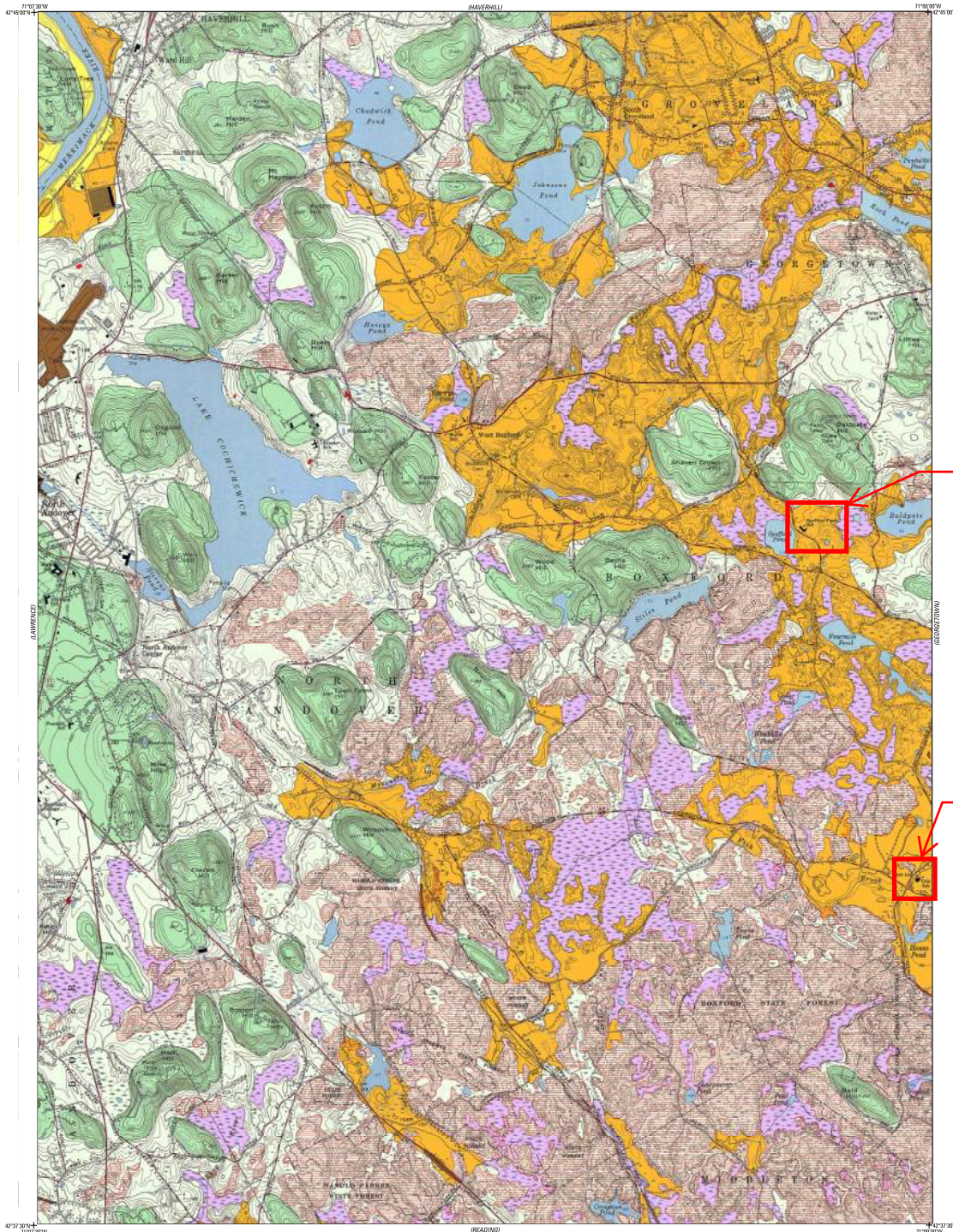

Spofford
Pond
School

Harry Lee
Cole School

Base from U.S. Geological Survey, 1986
Map was scanned, processed, georeferenced,
rectified, and cropped by the Massachusetts
Geological Survey
Lambert Conformal Conic projection, North American
Datum of 1983
Massachusetts state plane coordinate system,
measured zone

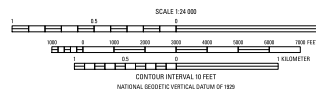

Map units were reproduced from Stone, B.D., 1982, unpublished field maps. Some bedrock outcrops are from Bell (1976). Some units were reinterpreted or revised from analogs of topographic field data and 2005 orthophoto images.

Surficial Materials Map of the South Groveland Quadrangle, Massachusetts

Compiled by
Byron D. Stone, Janet R. Stone, and Mary L. DiGiacomo-Cohen
2018

Any use of trade, firm, or product names is for descriptive purposes only and does not imply endorsement by the U.S. Government.
For sale by U.S. Geological Survey, Box 2088, Denver Federal Center,
Denver, CO 80220, <https://www.usgs.gov>; 1-888-603-4363 (toll-free) or 303-231-4343.
Suggested citation: Stone, B.D., Stone, J.R., and DiGiacomo-Cohen, M.L.,
compilers, 2018, Surficial materials map of the South Groveland quadrangle,
Massachusetts, quadrangle 123 in Stone, J.R., Stone, B.D., DiGiacomo-Cohen,
M.L., and Johnson, S.E., compilers, Surficial materials of Massachusetts—at
1:25,000 scale (large map edition), U.S. Geological Survey Scientific
Investigations Map 3402, 1 sheet, scale 1:24,000, <https://doi.org/10.3133/sim3402>.
ISSN 2209-1224 (online)
<https://doi.org/10.3133/sim3402>

Description of Map Units

Postglacial Deposits



Artificial fill—Earth materials and manmade materials that have been artificially emplaced, primarily in highway and railroad embankments and in dams; unit may also include landfills, urban-development areas, and filled coastal wetlands



Cranberry bog deposits—Natural freshwater swamps or peat bogs overlain locally by artificially emplaced sand or other fill; these deposits occur primarily in southeastern Massachusetts and on Cape Cod. Commonly, cranberry bogs also are created by excavation into sand and gravel deposits that form the bed; peat and other organic material are then artificially emplaced over the bed, and water drainage pathways are diverted into the area to control seasonal flooding of the bog



Flood-plain alluvium—Sand, gravel, silt, and some organic material, stratified and well sorted to poorly sorted, beneath the flood plains of modern streams. The texture of alluvium commonly varies over short distances both laterally and vertically, and generally is similar to the texture of adjacent glacial deposits. Along smaller streams, alluvium is commonly less than 5 feet (ft) thick. The most extensive deposits of alluvium in Massachusetts are along the Housatonic, Deerfield, Westfield, Connecticut, Nashua, Merrimack, and Blackstone Rivers. Alluvium typically overlies thicker glacial stratified deposits



Swamp deposits—Organic muck and peat that contain minor amounts of sand, silt, and clay, are stratified and poorly sorted, and occur in swamps and freshwater marshes, in kettle depressions, or in poorly drained areas. Unit is shown only where deposits are estimated to be at least 3 ft thick; most deposits are less than 10 ft thick. Swamp deposits overlie glacial deposits or bedrock. They locally overlie glacial till even where they occur within thin glacial meltwater deposits



Salt-marsh and estuarine deposits—Peat and organic muck interbedded with sand and silt, deposited in saltwater or brackish-water environments of low wave energy along the coast and in river estuaries. Salt-marsh deposits are dominantly peat and muck, generally a few feet to 25 ft thick. In the major estuaries, these deposits locally overlie estuarine deposits (not mapped), which are sand and silt with minor organic material and are as much as 30 to 80 ft thick. Salt-marsh and estuarine deposits generally are underlain by adjacent glacial material, consisting of till, coarse stratified deposits, or glaciomarine fine deposits



Beach and dune deposits—Sand and fine gravel deposited along the shoreline by waves and currents, and by wind action. The texture of beach deposits varies over short distances and is generally controlled by the texture of nearby glacial materials exposed to wave action. Sand beach deposits are composed of moderately sorted, very coarse to fine sand, and are commonly laminated. Coarser layers may contain some fine gravel particles; finer layers may contain some very fine sand and silt. Gravel beach deposits are composed of granule- to cobble-size clasts in moderately sorted thin beds; deposits contain minor amounts of sand within gravel beds, and thin beds of sand as alternating layers. Beach deposits are rarely more than a few feet thick. Dune deposits are composed of moderately sorted to well-sorted, fine to medium sand, and are variably massive, laminated, and crossbedded. Dune deposits are as much as 100 ft thick. Unit includes artificial sand deposits in locally replenished beaches

Early Postglacial Deposits



Alluvial-fan deposits—Generally coarse gravel and sand deposits on steep slopes where high-gradient streams entered lower gradient valleys. Alluvial fans in some places were graded to lowering levels of glacial lakes. Fans continue to form today at some locations in Massachusetts

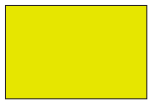

Valley-floor fluvial deposits—Sand, gravel, and minor silt, stratified and moderately to poorly sorted, beneath flat floors of valleys, called furrows (Mather and others, 1942), that are eroded into glacial outwash plains. The texture of the fluvial deposits commonly varies over short distances both laterally and vertically, and generally is similar to the texture of adjacent glacial deposits. The fluvial deposits overlie thick glacial stratified deposits in the upper, dry reaches of the furrow valleys and probably are less than 20 ft thick. Swamp deposits and deformation of bedding related to melting of buried ice in kettles interrupt the fluvial deposits. The deposits probably extend beneath salt-marsh and estuarine deposits in coastal valley reaches. The most extensive valley-floor fluvial deposits are on upper Cape Cod along Quaker Run and the Coonamessett, Childs, and Quashnet Rivers, and on Martha’s Vineyard in Quampache Bottom



Stream-terrace deposits—Sand, gravel, and silt deposited by meteoric water (locally distal meltwater) on terraces cut into glacial meltwater sediments along rivers and streams. These deposits are shown where they overlie glaciolacustrine deposits (fine deposits map unit) and glaciomarine fine deposits; elsewhere, stream-terrace deposits are included in the coarse deposits map unit. Most stream-terrace deposits are less than 10 ft thick and overlie thicker glacial deposits; textures are commonly similar to those of underlying glacial meltwater deposits. Many stream terraces in the Connecticut River valley are composed of fine to medium sand and overlie lake-bottom silt and clay



Marine regressive deposits—Sand and minor gravel deposited along former, higher shorelines in northeastern Massachusetts by waves and currents, and by wind action on beaches and spits. These deposits are shown where they overlie glaciomarine fine deposits. Regressive beach and nearshore deposits are composed of moderately sorted, very coarse to fine sand, commonly laminated. Coarser layers may contain some fine gravel particles; finer layers may contain some very fine sand and silt. Regressive beach and nearshore deposits are rarely more than a few feet thick. Regressive spit deposits are 10 to 30 ft thick



Inland-dune deposits—Fine to medium, well-sorted sand in transverse, parabolic, and hummocky dunes as much as 60 ft thick. Deposits occur mostly in the glacial Lake Hitchcock basin (in the Connecticut Valley lowland), where sand derived from extensive glacial-lake deltas that were not yet vegetated was deposited in dune forms by early postglacial winds. Dune sand is now fixed by vegetation except where disturbed by human activities



Talus deposits—Angular, loose blocks of basalt and diabase accumulated by rockfall and creep at the base of bedrock cliffs along linear traprock ridges in the Mesozoic lowland (Connecticut Valley lowland). Talus deposits form steep, unstable slopes. Generally less than 20 ft thick

Glacial Stratified Deposits

Sorted and stratified sediments composed of gravel, sand, silt, and clay (as defined in the particle-size diagram, figure 12, below), deposited in layers by glacial meltwater. These sediments occur as four basic textural units: gravel deposits, sand and gravel deposits, sand deposits, and fine deposits. On this surficial geologic map, gravel deposits, sand and gravel deposits, and sand deposits are not differentiated and are shown as *Coarse Deposits* where they occur at the land surface. *Fine Deposits* also are shown where they occur at the land surface. Textural changes occur both areally and vertically (fig. 9); however, subsurface textural variations are not shown on this map.

PARTICLE DIAMETER										
10	2.5	.16	.08	.04	.02	.01	.005	.0025	.00015	inches
256	64	4	2	1	.5	.25	.125	.063	.004	mm
Boulders	Cobbles	Pebbles	Granules	Very coarse sand	Coarse sand	Medium sand	Fine sand	Very fine sand	Silt	Clay
GRAVEL PARTICLES				SAND PARTICLES				FINE PARTICLES		

Figure 12. Grain-size classification used in this report, modified from Wentworth (1922). Abbreviation: mm, millimeter.



Coarse deposits consist of *gravel deposits*, *sand and gravel deposits*, and *sand deposits*, not differentiated in this report. *Gravel deposits* are composed of at least 50 percent gravel-size clasts; cobbles and boulders predominate; minor amounts of sand occur within gravel beds, and sand comprises a few separate layers. Gravel layers generally are poorly sorted, and bedding commonly is distorted and faulted due to postdepositional collapse related to melting of ice. *Sand and gravel deposits* occur as mixtures of gravel and sand within individual layers and as layers of sand alternating with layers of gravel. Sand and gravel layers generally range between 25 and 50 percent gravel particles and between 50 and 75 percent sand particles. Layers are well sorted to poorly sorted; bedding may be distorted and faulted due to postdepositional collapse. *Sand deposits* are composed mainly of very coarse to fine sand, commonly in well-sorted layers. Coarser layers may contain up to 25 percent gravel particles, generally granules and pebbles; finer layers may contain some very fine sand, silt, and clay

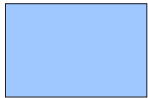

Fine deposits include very fine sand, silt, and clay that occur as well-sorted, thin layers of alternating silt and clay (varves), or as thicker layers of very fine sand and silt. Very fine to fine sand commonly occurs at the surface of these lake-bottom deposits and grades downward into rhythmically bedded silt and clay varves. In some places on the lake-bottom surface of glacial Lake Hitchcock (in the Connecticut Valley lowland) and glacial Lake Narragansett (in southeastern Massachusetts), fine deposits are overlain by as much as 30 ft of fine to medium sand, deposited as the lake level lowered or the lake shallowed; this sand has not been mapped separately. Locally, this map unit may include areas underlain by fine sand



Glaciomarine fine deposits include clay, silty clay, fine sand, and some fine gravel deposited in a higher-level sea in environments of low wave energy along the coast and in river estuaries. Fine to very fine sand, massive and laminated, commonly is present at the surface and grades downward into interbedded very fine sand, silt, silty clay, and clay. The lower silty clay and clay is massive and thinly laminated. Total thickness is generally a few feet to 75 ft



Stagnant-ice deposits—Surface coarse sediments include scattered large surface boulders, gravel deposits, and sand and gravel deposits, totaling 5 to 30 ft thick, that overlie predominantly sand deposits. Sand deposits contain deltaic foreset bedding and interlayered beds of fine sand, silt, and a little clay. Sand and silty sand deposits extend downward to basal till and bedrock. Flowtill sediments are interlayered under ice-contact slopes. Stratification in surface and underlying sediments is generally distorted and faulted due to postdepositional collapse related to melting of buried ice. Stagnant-ice deposits are confined to irregular hummocky hills, bounded by ice-contact slopes, present on tops of till hills or extending more than 30 ft above the altitudes of adjacent meltwater morphosequences in lowlands. Deposits are aligned in belts parallel to the retreating ice margin

Glacial Till and Moraine Deposits



End moraine deposits—Composed predominantly of boulders and ablation-facies sandy upper till; lenses of stratified sand and gravel occur locally within the till. In the larger deposits on Cape Cod and Martha's Vineyard, the surface ablation till is as much as 30 ft thick and overlies sand, gravel, and silty sand meltwater deposits. Some end moraine deposits include thrust sheets of glacial meltwater deposits resulting from readvance of the ice margin (Oldale and O'Hara, 1984). Stratification in underlying sediments may also be deformed, the result of postdepositional collapse caused by melting of buried ice. Surface boulders on end moraine deposits are generally more numerous than on adjacent till surfaces; dense concentrations of boulders are present in some places. Deposits occur as freestanding hummocky landforms, commonly in ridges that trend east-northeast to west-southwest, and range in height from 10 to 100 ft



Thrust moraine deposits—In western Martha's Vineyard, thrust moraine deposits stand as high as 300 ft in altitude and are composed of allochthonous, ice-thrusted Cretaceous, Tertiary, and older Quaternary sediments, locally overlain by thin surface till and boulders. These coastal-plain beds are fossiliferous, semi-consolidated sand, gravel, and silty clay in tilted strata that were thrust up by glacial ice into positions well above the autochthonous coastal-plain surface, which lies below sea level. Numerous northeast-southwest-trending ridges within the thrust moraine unit mark the edges of these tilted and thrust strata



Thin till—Nonsorted, nonstratified matrix of sand, some silt, and little clay containing scattered pebble, cobble, and boulder clasts; large surface boulders are common; unit was mapped where till is generally less than 10 to 15 ft thick including areas of shallow bedrock. Predominantly consists of upper till of the last glaciation; loose to moderately compact, generally sandy, commonly stony. Two facies are present in some places: a looser, coarser grained ablation facies, melted out from supraglacial position; and an underlying more compact, finer grained lodgement facies deposited subglacially. In general, both ablation and lodgement facies of upper till derived from fine-grained bedrock are finer grained, more compact, less stony and have fewer surface boulders than upper till derived from coarse-grained crystalline rocks. Across Massachusetts, fine-grained bedrock sources include the red Mesozoic sedimentary rocks of the Connecticut Valley lowland, marble in the western river valleys, and fine-grained schists in upland areas



Thick till—Nonsorted, nonstratified matrix of sand, some silt, and little clay containing scattered pebbles, cobbles, and boulders in the shallow subsurface; at greater depths consists of compact, nonsorted matrix of silt, very fine sand, and some clay containing scattered small gravel clasts. Mapped in areas where till is greater than 10 to 15 ft thick, mostly in drumlin landforms in which till thickness commonly exceeds 100 ft (maximum recorded thickness is 230 ft). Although upper till of late Wisconsinan age is the surface deposit, lower till of probable Illinoian age constitutes the bulk of the material in thick-till areas. Lower till is moderately to very compact and is commonly finer grained and less stony than upper till. An oxidized zone, the lower part of a soil profile formed during a period of interglacial weathering, is generally present in the upper part of the lower till. This zone commonly shows closely spaced joints that are stained with iron and manganese oxides



Glacially modified coastal-plain hill deposits—In the Marshfield Hills area (Scituate, Cohasset, Hanover, and Duxbury quadrangles) and in the Pine Hills area (Manomet quadrangle), very compact till and older glacial stratified deposits overlie thrust blocks of Tertiary coastal-plain strata that are semi-consolidated dark clay layers. Miocene-age green sand deposits have also been reported at depth. These hills in many places were sculpted by the last ice sheet, but they are generally larger (3–4 miles [mi] long and 1–2 mi wide) than typical drumlins



Thick valley till and fine deposits—Composed of sandy surface till with boulders, 3 to 20 ft thick, overlying finer grained till, or fine sand, silt, or clay, local boulders, and local weathered limestone and dolostone bedrock; total thickness of all sediments is 6 to 135 ft, averaging 50 ft. Materials reported in drillers' records include four descriptions usually synonymous with till: hardpan with no boulders; boulders and clay; gravelly hardpan; and clay with few boulders. Unit includes materials probably defining glaciolacustrine fine sediments or various weathered carbonate bedrock materials, listed as follows: gray clay, gray and yellow clay, black soft rock, and weathered bedrock. The subsurface fine sediments are exposed only in fresh, temporary landslide slopes or shallow excavations, where silty-clayey fine sand typically appears to be sheared, deformed, or disaggregated. Original laminations are difficult to discern. Surface morphology of the thick valley till and fine deposits includes (1) a glacially smoothed surface without bedrock outcrops or any relief related to bedrock structure; (2) locally a streamlined shape similar to small drumlins composed of thick till in other parts of Massachusetts; (3) landslide scarps and stream-cut banks commonly having 5 to 10 ft of relief, locally as much as 50 ft; and (4) dry, meltwater-carved channels 3 to 10 ft deep. These deposits extend almost continuously along lower valley slopes in the Housatonic and Hoosic River valleys, and their tributary valleys, that are underlain by marble, dolostone, or limestone and shale bedrock (Zen and others, 1983). The deposits appear to extend beneath the edges of glacial meltwater deposits in the valley bottoms, but their extent beneath thick glacial deposits in the centers of the valleys is not known. Some of these deposits are present in north-draining upland valleys in areas that also contain thick till deposits in drumlins

Bedrock Areas



Bedrock outcrops and areas of abundant outcrop or shallow bedrock—Solid color shows extent of individual bedrock outcrops; horizontal-line pattern indicates areas of shallow bedrock or areas where small outcrops are too numerous to map individually; in areas of shallow bedrock, surficial materials are less than 5 to 10 ft thick. These units were not mapped consistently among all quadrangles; see note at beginning of appendix 1 for information on bedrock outcrop mapping by quadrangle

Attachment D - HydroCAD Reports

Spofford School
 Boxford, MA
 Stormwater Discharge Summary Table
 1-Nov-21

Analysis Point	24 Hr Storm	Peak Discharge (cfs)		Runoff Volume (cf)	
		Pre-Development	Post-Development	Pre-Development	Post-Development
1L	2yr	0.00	0.00	0	0
	10yr	0.00	0.00	0	0
	25yr	0.00	0.00	43	43
	50yr	0.01	0.01	187	187
	100yr	0.04	0.04	399	399
2L	2yr	0.00	0.00	0	0
	10yr	0.00	0.00	95	0
	25yr	0.02	0.00	346	41
	50yr	0.10	0.01	810	180
	100yr	0.24	0.03	1,374	384
3L	2yr	0.01	0.00	184	0
	10yr	0.20	0.01	1,736	224
	25yr	0.67	0.06	3,515	713
	50yr	1.56	0.20	6,187	1,713
	100yr	2.54	0.45	9,089	2,980
4L	2yr	11.54	7.49	39,005	44,195
	10yr	19.49	11.53	65,836	73,393
	25yr	25.12	13.65	84,998	94,066
	50yr	31.84	16.42	108,076	118,899
	100yr	38.09	23.27	129,653	142,089

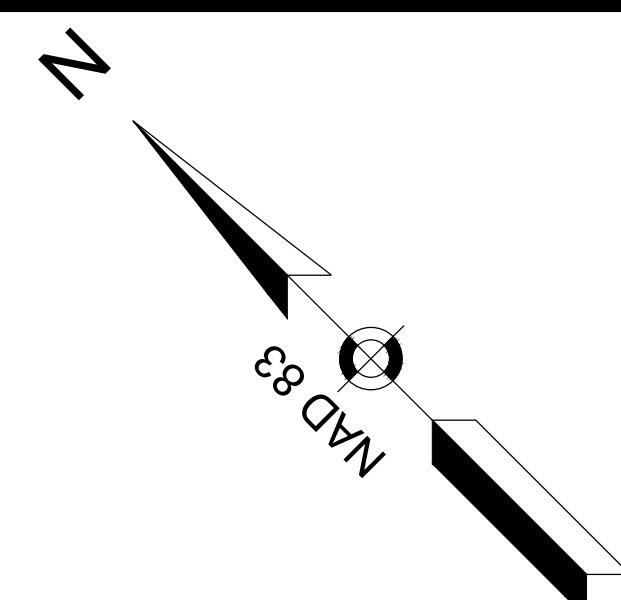

Project:
BOXFORD PUBLIC SCHOOLS SITE RENOVATION PROJECT

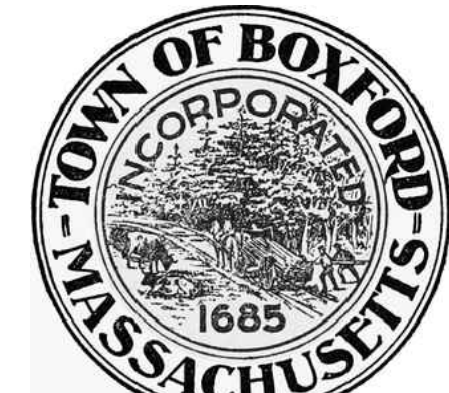

TOWN OF BOXFORD MASSACHUSETTS
 1685

SPOFFORD POND SCHOOL
 31 SPOFFORD ROAD
 BOXFORD, MA 01921

Weston & Sampson

Weston & Sampson Engineers, Inc.
 55 Walkers Brook Drive, Suite 100
 Reading, MA 01867
 978.532.1900 800.SAMPSON
 www.westonandsampson.com

Consultants:

Revisions:

No.	Date	Description
1	10/08/21	PER PEER REVIEW
2	11/01/21	PER PEER REVIEW

Seal:

Issued For:

PERMITTING ONLY
 NOT FOR CONSTRUCTION

Scale: AS SHOWN

Date: JULY 23, 2021

Drawn By: CTK

Reviewed By: JIP

Approved By: JIP

W&S Project No.: ENG20-0865

W&S File No.:

Drawing Title:

PRE-DEVELOPMENT PLAN
SPOFFORD POND SCHOOL

Sheet Number:

FIG.1

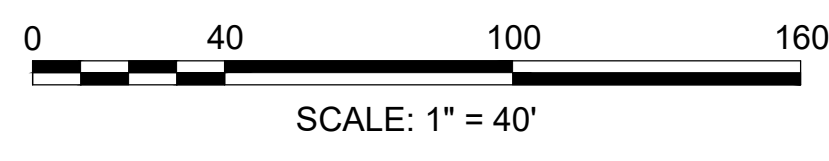
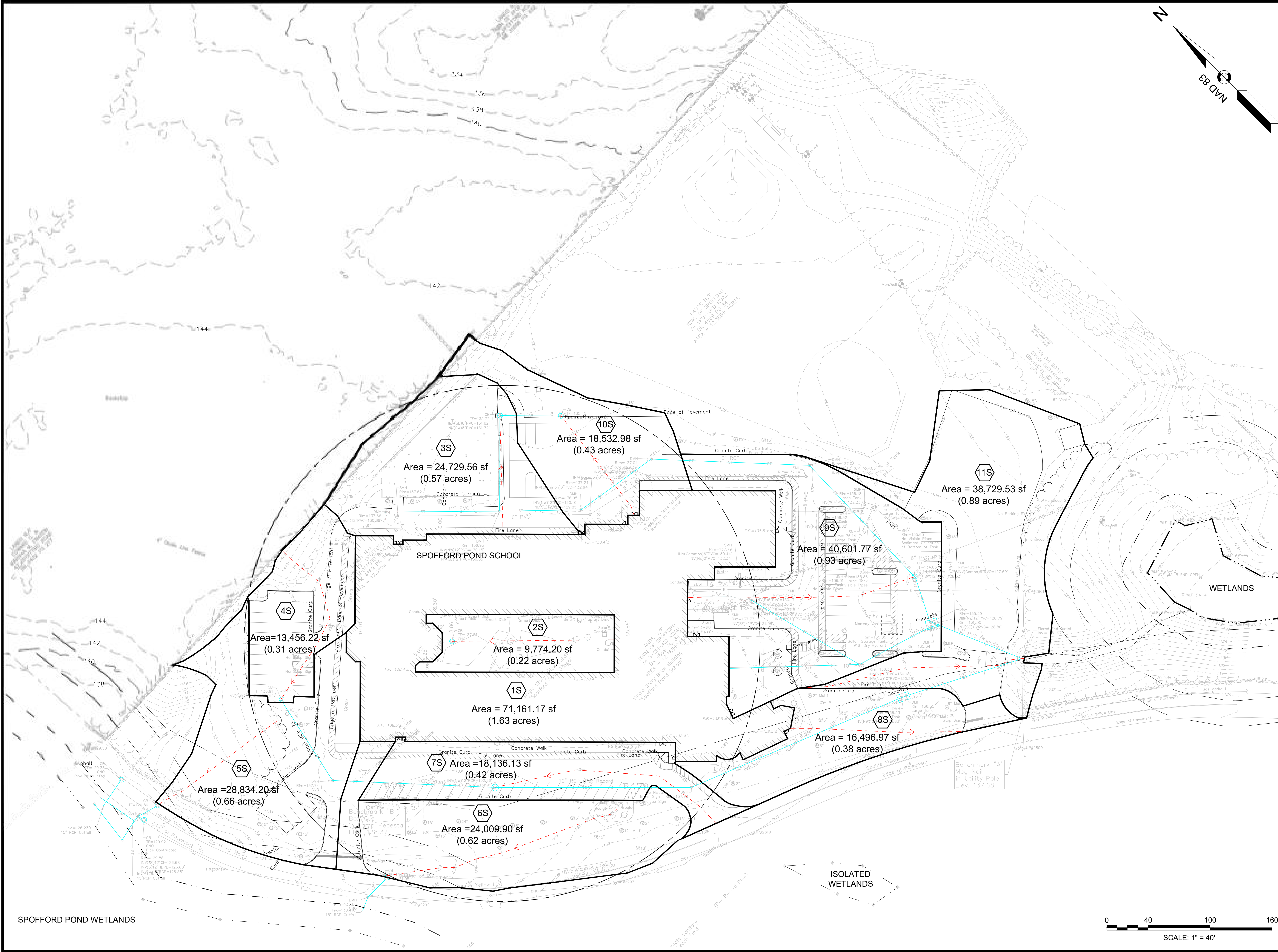

Rev. 18 Date: 10/24/2019

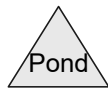
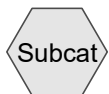
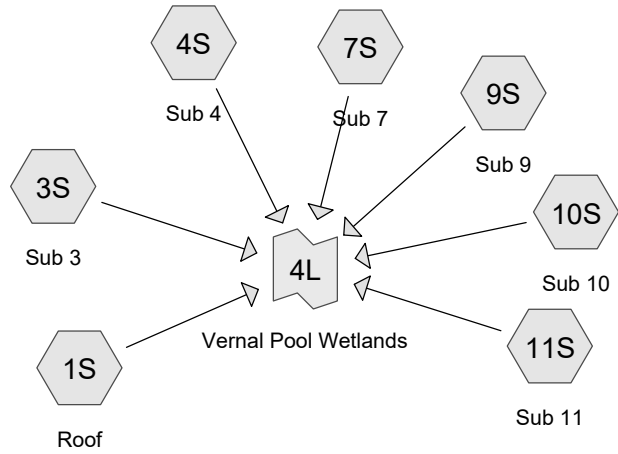
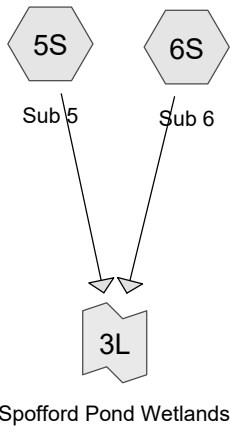
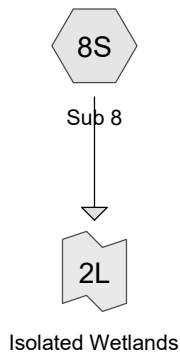
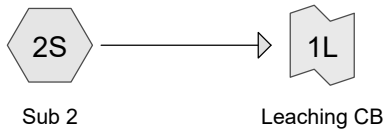

Spofford Pre-Development

Prepared by Weston & Sampson

HydroCAD® 10.10-6a s/n 00455 © 2020 HydroCAD Software Solutions LLC

Printed 11/2/2021

Page 2

Rainfall Events Listing

Event#	Event Name	Storm Type	Curve	Mode	Duration (hours)	B/B	Depth (inches)	AMC
1	2-year	Type III 24-hr		Default	24.00	1	3.10	2
2	10-year	Type III 24-hr		Default	24.00	1	4.70	2
3	25-year	Type III 24-hr		Default	24.00	1	5.80	2
4	50-year	Type III 24-hr		Default	24.00	1	7.10	2
5	100-year	Type III 24-hr		Default	24.00	1	8.30	2

Spofford Pre-Development

Prepared by Weston & Sampson

HydroCAD® 10.10-6a s/n 00455 © 2020 HydroCAD Software Solutions LLC

Printed 11/2/2021

Page 3

Area Listing (all nodes)

Area (sq-ft)	CN	Description (subcatchment-numbers)
19,248	98	Compacted Gravel (11S)
82,571	30	Grass (2S, 3S, 4S, 5S, 6S, 7S, 8S, 9S, 10S, 11S)
107,595	98	Paved parking, HSG A (3S, 4S, 5S, 6S, 7S, 8S, 9S, 10S, 11S)
71,161	98	Roofs, HSG A (1S)
9,104	98	Turf (impervious) (3S)
17,838	30	Woods, Good, HSG A (3S, 4S, 5S, 10S, 11S)
307,517	76	TOTAL AREA

Spofford Pre-Development

Prepared by Weston & Sampson

HydroCAD® 10.10-6a s/n 00455 © 2020 HydroCAD Software Solutions LLC

Printed 11/2/2021

Page 4

Soil Listing (all nodes)

Area (sq-ft)	Soil Group	Subcatchment Numbers
196,594	HSG A	1S, 3S, 4S, 5S, 6S, 7S, 8S, 9S, 10S, 11S
0	HSG B	
0	HSG C	
0	HSG D	
110,923	Other	2S, 3S, 4S, 5S, 6S, 7S, 8S, 9S, 10S, 11S
307,517		TOTAL AREA

Spofford Pre-Development

Prepared by Weston & Sampson

HydroCAD® 10.10-6a s/n 00455 © 2020 HydroCAD Software Solutions LLC

Printed 11/2/2021

Page 5

Ground Covers (all nodes)

HSG-A (sq-ft)	HSG-B (sq-ft)	HSG-C (sq-ft)	HSG-D (sq-ft)	Other (sq-ft)	Total (sq-ft)	Ground Cover	Subcatch Numbers
0	0	0	0	19,248	19,248	Compacted Gravel	
0	0	0	0	82,571	82,571	Grass	
107,595	0	0	0	0	107,595	Paved parking	
71,161	0	0	0	0	71,161	Roofs	
0	0	0	0	9,104	9,104	Turf (impervious)	
17,838	0	0	0	0	17,838	Woods, Good	
196,594	0	0	0	110,923	307,517	TOTAL AREA	

Time span=1.00-36.00 hrs, dt=0.01 hrs, 3501 points
 Runoff by SCS TR-20 method, UH=SCS, Weighted-CN
 Reach routing by Dyn-Stor-Ind method - Pond routing by Dyn-Stor-Ind method

Subcatchment1S: Roof	Runoff Area=71,161 sf 100.00% Impervious Runoff Depth=2.87" Tc=6.0 min CN=98 Runoff=4.91 cfs 17,007 cf
Subcatchment2S: Sub 2	Runoff Area=9,774 sf 0.00% Impervious Runoff Depth=0.00" Tc=6.0 min CN=30 Runoff=0.00 cfs 0 cf
Subcatchment3S: Sub 3	Runoff Area=24,730 sf 73.09% Impervious Runoff Depth=1.33" Tc=6.0 min CN=80 Runoff=0.87 cfs 2,732 cf
Subcatchment4S: Sub 4	Runoff Area=13,456 sf 63.32% Impervious Runoff Depth=0.92" Tc=6.0 min CN=73 Runoff=0.31 cfs 1,031 cf
Subcatchment5S: Sub 5	Runoff Area=28,834 sf 23.36% Impervious Runoff Depth=0.05" Tc=6.0 min CN=46 Runoff=0.00 cfs 109 cf
Subcatchment6S: Sub 6	Runoff Area=27,064 sf 22.29% Impervious Runoff Depth=0.03" Tc=6.0 min CN=45 Runoff=0.00 cfs 75 cf
Subcatchment7S: Sub 7	Runoff Area=18,136 sf 97.29% Impervious Runoff Depth=2.65" Tc=6.0 min CN=96 Runoff=1.21 cfs 4,006 cf
Subcatchment8S: Sub 8	Runoff Area=16,497 sf 9.02% Impervious Runoff Depth=0.00" Tc=6.0 min CN=36 Runoff=0.00 cfs 0 cf
Subcatchment9S: Sub 9	Runoff Area=40,602 sf 98.20% Impervious Runoff Depth=2.76" Tc=6.0 min CN=97 Runoff=2.76 cfs 9,330 cf
Subcatchment10S: Sub 10	Runoff Area=18,533 sf 69.05% Impervious Runoff Depth=1.14" Tc=6.0 min CN=77 Runoff=0.55 cfs 1,762 cf
Subcatchment11S: Sub 11	Runoff Area=38,730 sf 63.98% Impervious Runoff Depth=0.97" Tc=6.0 min CN=74 Runoff=0.95 cfs 3,138 cf
Link 1L: Leaching CB	Inflow=0.00 cfs 0 cf Primary=0.00 cfs 0 cf
Link 2L: Isolated Wetlands	Inflow=0.00 cfs 0 cf Primary=0.00 cfs 0 cf
Link 3L: Spofford Pond Wetlands	Inflow=0.01 cfs 184 cf Primary=0.01 cfs 184 cf
Link 4L: Vernal Pool Wetlands	Inflow=11.54 cfs 39,005 cf Primary=11.54 cfs 39,005 cf

Total Runoff Area = 307,517 sf Runoff Volume = 39,189 cf Average Runoff Depth = 1.53"
32.65% Pervious = 100,409 sf 67.35% Impervious = 207,108 sf

Spofford Pre-Development

Prepared by Weston & Sampson

HydroCAD® 10.10-6a s/n 00455 © 2020 HydroCAD Software Solutions LLC

Type III 24-hr 2-year Rainfall=3.10"

Printed 11/2/2021

Page 7

Summary for Subcatchment 1S: Roof

Runoff = 4.91 cfs @ 12.08 hrs, Volume= 17,007 cf, Depth= 2.87"

Routed to Link 4L : Vernal Pool Wetlands

Runoff by SCS TR-20 method, UH=SCS, Weighted-CN, Time Span= 1.00-36.00 hrs, dt= 0.01 hrs
Type III 24-hr 2-year Rainfall=3.10"

Area (sf)	CN	Description
71,161	98	Roofs, HSG A
71,161		100.00% Impervious Area

Tc (min)	Length (feet)	Slope (ft/ft)	Velocity (ft/sec)	Capacity (cfs)	Description
6.0					Direct Entry,

Subcatchment 1S: Roof

Hydrograph

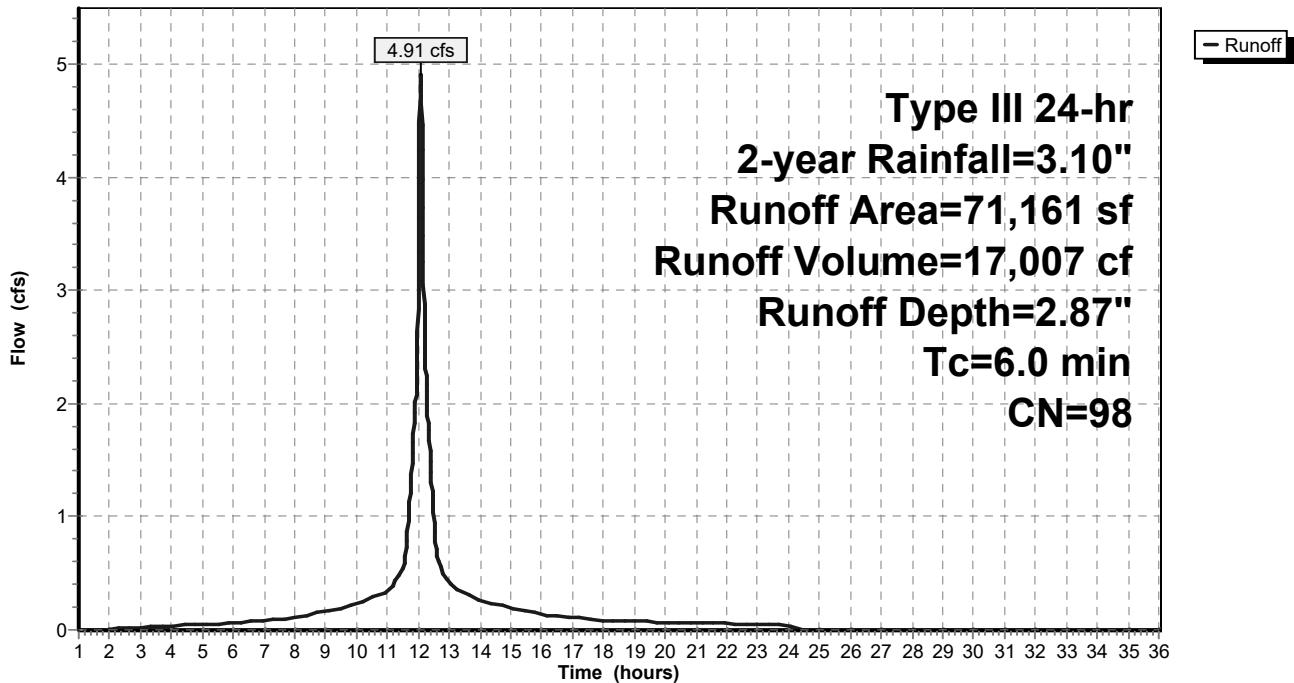

Spofford Pre-Development

Prepared by Weston & Sampson

HydroCAD® 10.10-6a s/n 00455 © 2020 HydroCAD Software Solutions LLC

Type III 24-hr 2-year Rainfall=3.10"

Printed 11/2/2021

Page 8

Summary for Subcatchment 2S: Sub 2

Runoff = 0.00 cfs @ 1.00 hrs, Volume= 0 cf, Depth= 0.00"

Routed to Link 1L : Leaching CB

Runoff by SCS TR-20 method, UH=SCS, Weighted-CN, Time Span= 1.00-36.00 hrs, dt= 0.01 hrs
Type III 24-hr 2-year Rainfall=3.10"

Area (sf)	CN	Description
* 9,774	30	Grass
9,774		100.00% Pervious Area

Tc (min)	Length (feet)	Slope (ft/ft)	Velocity (ft/sec)	Capacity (cfs)	Description
6.0					Direct Entry,

Subcatchment 2S: Sub 2

Hydrograph

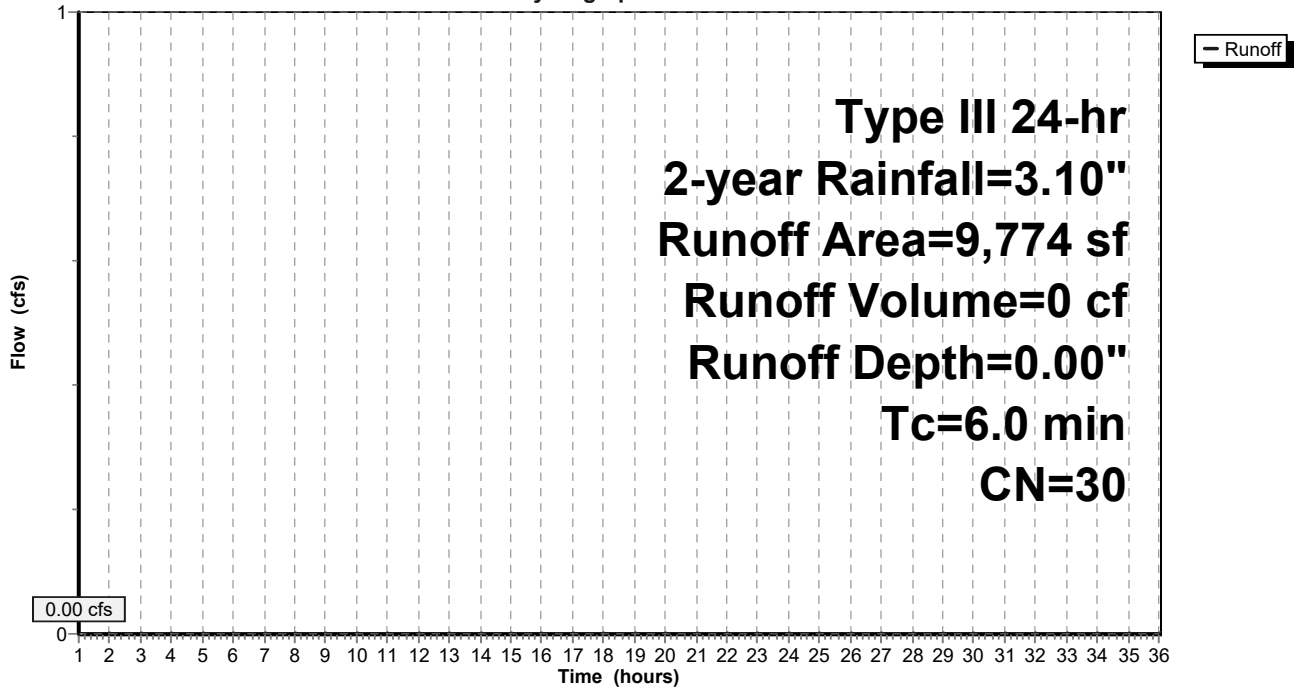

Spofford Pre-Development

Prepared by Weston & Sampson

HydroCAD® 10.10-6a s/n 00455 © 2020 HydroCAD Software Solutions LLC

Type III 24-hr 2-year Rainfall=3.10"

Printed 11/2/2021

Page 9

Summary for Subcatchment 3S: Sub 3

Runoff = 0.87 cfs @ 12.09 hrs, Volume= 2,732 cf, Depth= 1.33"
 Routed to Link 4L : Vernal Pool Wetlands

Runoff by SCS TR-20 method, UH=SCS, Weighted-CN, Time Span= 1.00-36.00 hrs, dt= 0.01 hrs
 Type III 24-hr 2-year Rainfall=3.10"

	Area (sf)	CN	Description
	8,972	98	Paved parking, HSG A
*	9,104	98	Turf (impervious)
*	5,760	30	Grass
	894	30	Woods, Good, HSG A
	24,730	80	Weighted Average
	6,654		26.91% Pervious Area
	18,076		73.09% Impervious Area

Tc (min)	Length (feet)	Slope (ft/ft)	Velocity (ft/sec)	Capacity (cfs)	Description
6.0					Direct Entry,

Subcatchment 3S: Sub 3

Hydrograph

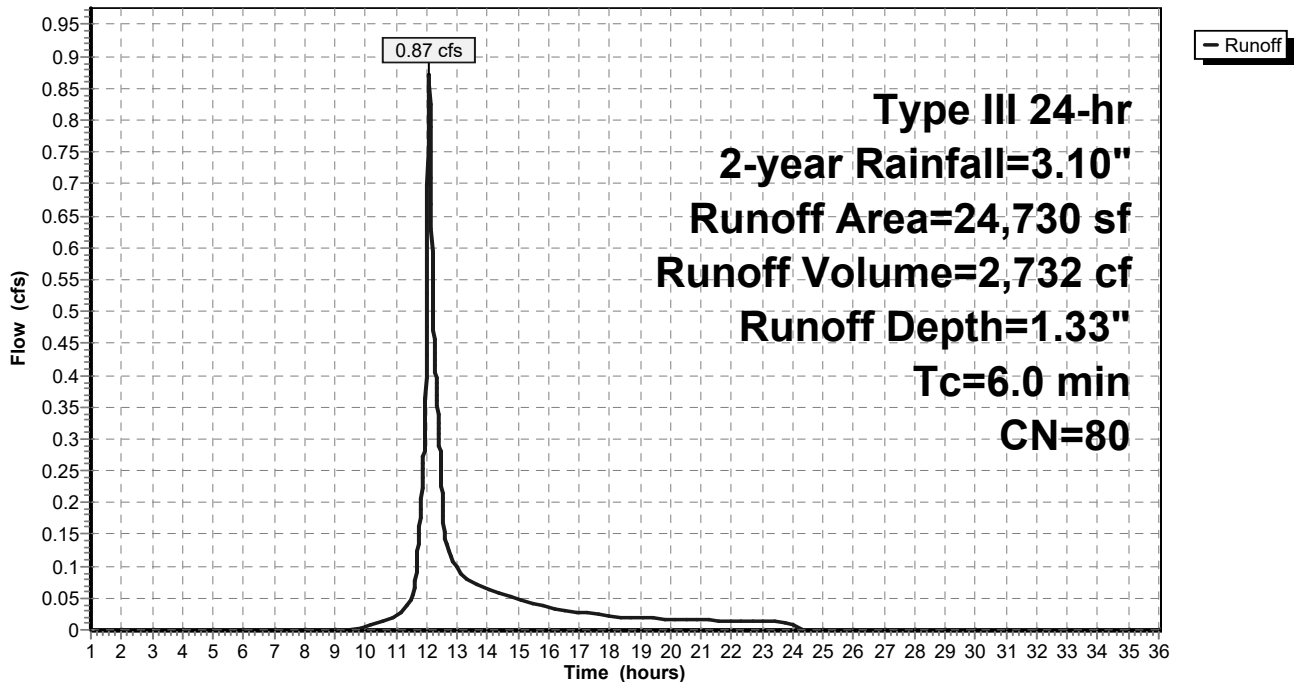

Spofford Pre-Development

Prepared by Weston & Sampson

HydroCAD® 10.10-6a s/n 00455 © 2020 HydroCAD Software Solutions LLC

Type III 24-hr 2-year Rainfall=3.10"

Printed 11/2/2021

Page 10

Summary for Subcatchment 4S: Sub 4

Runoff = 0.31 cfs @ 12.10 hrs, Volume= 1,031 cf, Depth= 0.92"
 Routed to Link 4L : Vernal Pool Wetlands

Runoff by SCS TR-20 method, UH=SCS, Weighted-CN, Time Span= 1.00-36.00 hrs, dt= 0.01 hrs
 Type III 24-hr 2-year Rainfall=3.10"

Area (sf)	CN	Description
8,521	98	Paved parking, HSG A
2,064	30	Woods, Good, HSG A
* 2,871	30	Grass
13,456	73	Weighted Average
4,935		36.68% Pervious Area
8,521		63.32% Impervious Area

Tc (min)	Length (feet)	Slope (ft/ft)	Velocity (ft/sec)	Capacity (cfs)	Description
6.0					Direct Entry,

Subcatchment 4S: Sub 4

Hydrograph

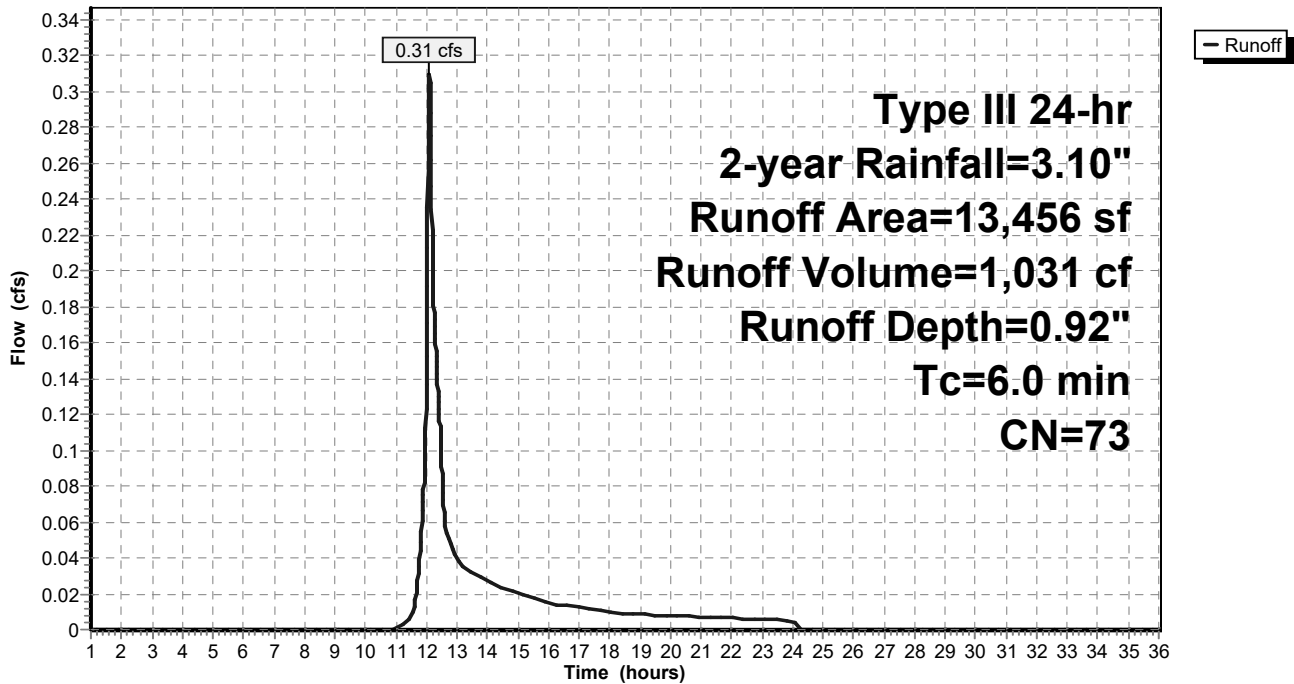

Spofford Pre-Development

Prepared by Weston & Sampson

HydroCAD® 10.10-6a s/n 00455 © 2020 HydroCAD Software Solutions LLC

Type III 24-hr 2-year Rainfall=3.10"

Printed 11/2/2021

Page 11

Summary for Subcatchment 5S: Sub 5

Runoff = 0.00 cfs @ 15.30 hrs, Volume= 109 cf, Depth= 0.05"

Routed to Link 3L : Spofford Pond Wetlands

Runoff by SCS TR-20 method, UH=SCS, Weighted-CN, Time Span= 1.00-36.00 hrs, dt= 0.01 hrs
 Type III 24-hr 2-year Rainfall=3.10"

Area (sf)	CN	Description
6,737	98	Paved parking, HSG A
9,957	30	Woods, Good, HSG A
* 12,140	30	Grass
28,834	46	Weighted Average
22,097		76.64% Pervious Area
6,737		23.36% Impervious Area

Tc (min)	Length (feet)	Slope (ft/ft)	Velocity (ft/sec)	Capacity (cfs)	Description
6.0					Direct Entry,

Subcatchment 5S: Sub 5

Hydrograph

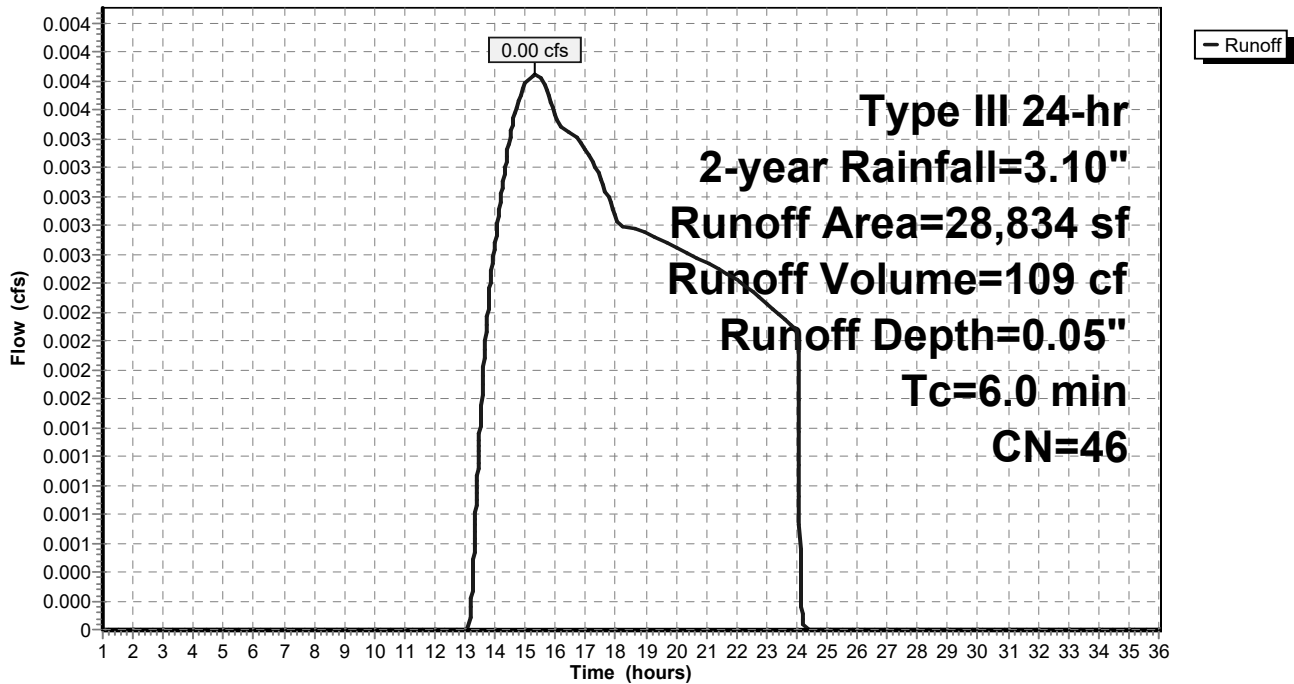

Spofford Pre-Development

Prepared by Weston & Sampson

HydroCAD® 10.10-6a s/n 00455 © 2020 HydroCAD Software Solutions LLC

Type III 24-hr 2-year Rainfall=3.10"

Printed 11/2/2021

Page 12

Summary for Subcatchment 6S: Sub 6

Runoff = 0.00 cfs @ 15.62 hrs, Volume= 75 cf, Depth= 0.03"

Routed to Link 3L : Spofford Pond Wetlands

Runoff by SCS TR-20 method, UH=SCS, Weighted-CN, Time Span= 1.00-36.00 hrs, dt= 0.01 hrs
 Type III 24-hr 2-year Rainfall=3.10"

Area (sf)	CN	Description
6,032	98	Paved parking, HSG A
* 21,032	30	Grass
27,064	45	Weighted Average
21,032		77.71% Pervious Area
6,032		22.29% Impervious Area

Tc (min)	Length (feet)	Slope (ft/ft)	Velocity (ft/sec)	Capacity (cfs)	Description
6.0					Direct Entry,

Subcatchment 6S: Sub 6

Hydrograph

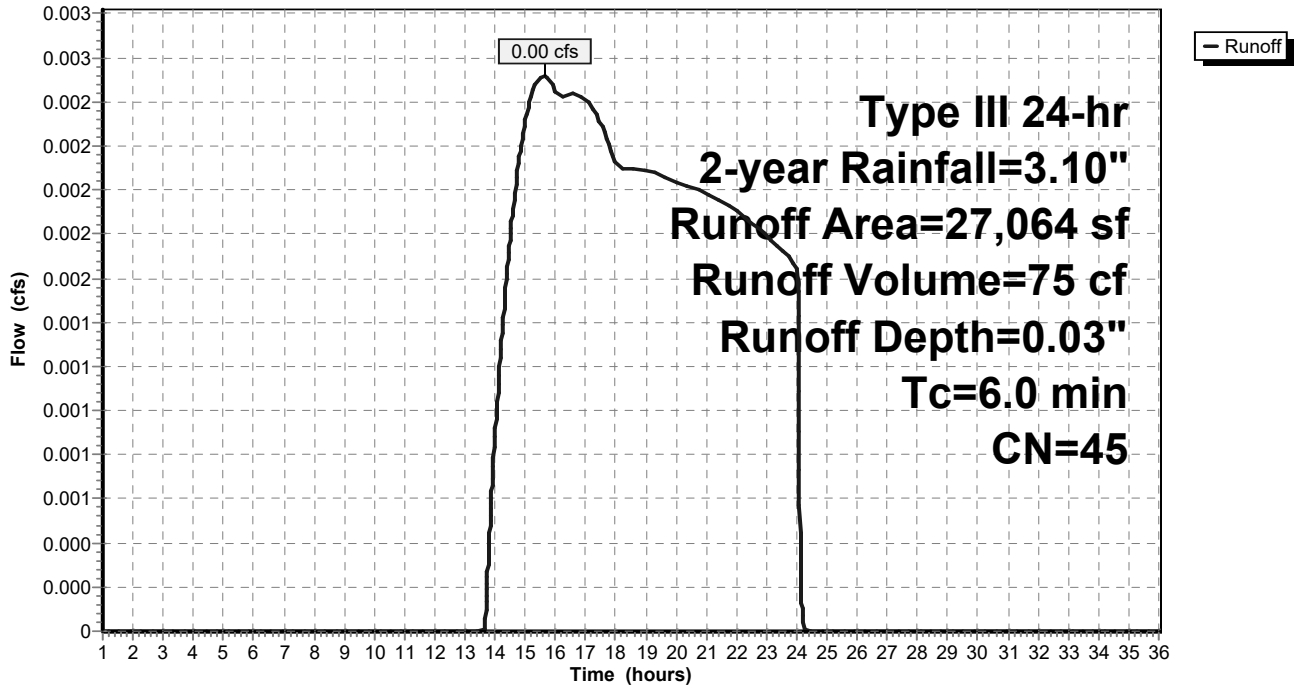

Spofford Pre-Development

Prepared by Weston & Sampson

HydroCAD® 10.10-6a s/n 00455 © 2020 HydroCAD Software Solutions LLC

Type III 24-hr 2-year Rainfall=3.10"

Printed 11/2/2021

Page 13

Summary for Subcatchment 7S: Sub 7

Runoff = 1.21 cfs @ 12.08 hrs, Volume= 4,006 cf, Depth= 2.65"
 Routed to Link 4L : Vernal Pool Wetlands

Runoff by SCS TR-20 method, UH=SCS, Weighted-CN, Time Span= 1.00-36.00 hrs, dt= 0.01 hrs
 Type III 24-hr 2-year Rainfall=3.10"

Area (sf)	CN	Description
17,644	98	Paved parking, HSG A
* 492	30	Grass
18,136	96	Weighted Average
492		2.71% Pervious Area
17,644		97.29% Impervious Area

Tc (min)	Length (feet)	Slope (ft/ft)	Velocity (ft/sec)	Capacity (cfs)	Description
6.0					Direct Entry,

Subcatchment 7S: Sub 7

Hydrograph

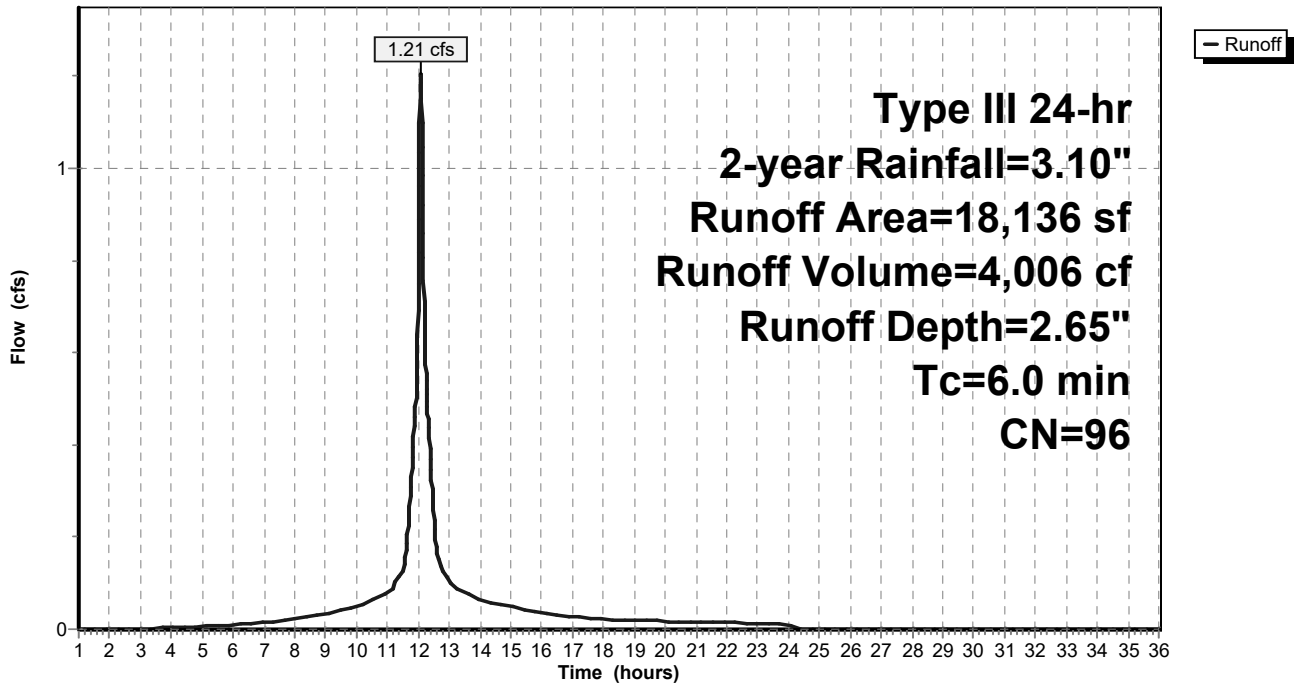

Spofford Pre-Development

Prepared by Weston & Sampson

HydroCAD® 10.10-6a s/n 00455 © 2020 HydroCAD Software Solutions LLC

Type III 24-hr 2-year Rainfall=3.10"

Printed 11/2/2021

Page 14

Summary for Subcatchment 8S: Sub 8

Runoff = 0.00 cfs @ 1.00 hrs, Volume= 0 cf, Depth= 0.00"
 Routed to Link 2L : Isolated Wetlands

Runoff by SCS TR-20 method, UH=SCS, Weighted-CN, Time Span= 1.00-36.00 hrs, dt= 0.01 hrs
 Type III 24-hr 2-year Rainfall=3.10"

Area (sf)	CN	Description
1,488	98	Paved parking, HSG A
* 15,009	30	Grass
16,497	36	Weighted Average
15,009		90.98% Pervious Area
1,488		9.02% Impervious Area

Tc (min)	Length (feet)	Slope (ft/ft)	Velocity (ft/sec)	Capacity (cfs)	Description
6.0					Direct Entry,

Subcatchment 8S: Sub 8

Hydrograph

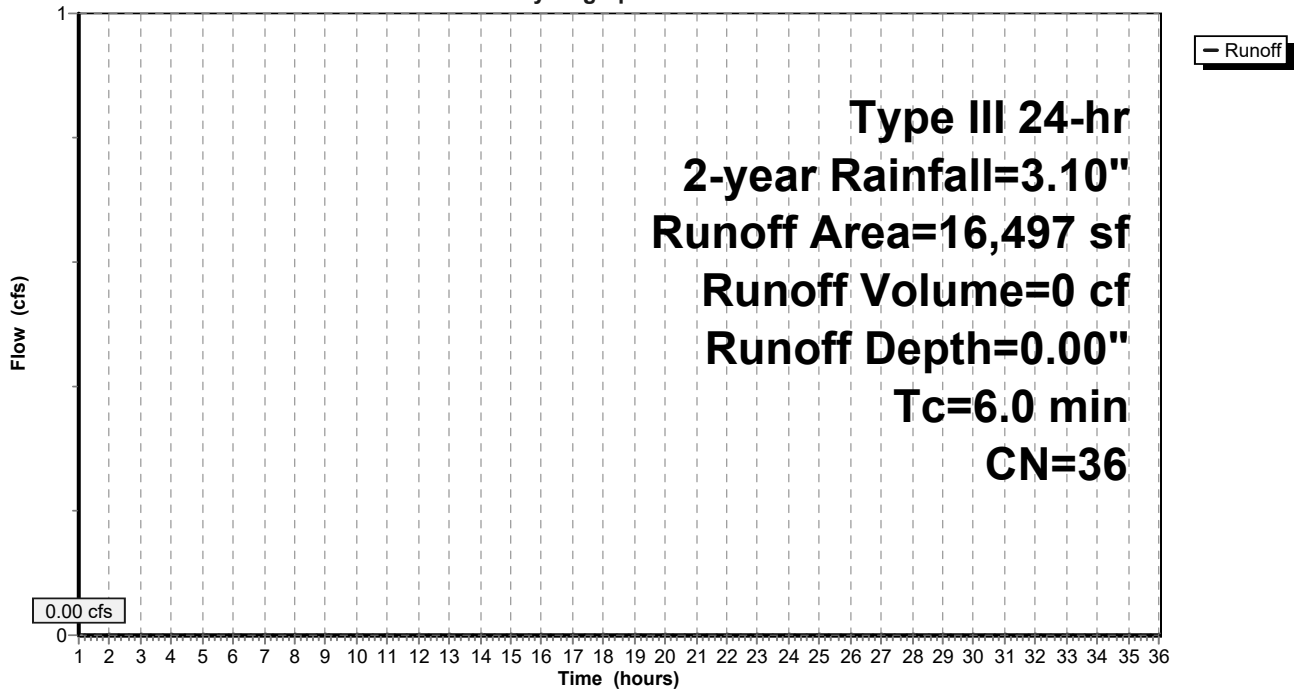

Spofford Pre-Development

Prepared by Weston & Sampson

HydroCAD® 10.10-6a s/n 00455 © 2020 HydroCAD Software Solutions LLC

Type III 24-hr 2-year Rainfall=3.10"

Printed 11/2/2021

Page 15

Summary for Subcatchment 9S: Sub 9

Runoff = 2.76 cfs @ 12.08 hrs, Volume= 9,330 cf, Depth= 2.76"
 Routed to Link 4L : Vernal Pool Wetlands

Runoff by SCS TR-20 method, UH=SCS, Weighted-CN, Time Span= 1.00-36.00 hrs, dt= 0.01 hrs
 Type III 24-hr 2-year Rainfall=3.10"

Area (sf)	CN	Description
39,871	98	Paved parking, HSG A
* 731	30	Grass
40,602	97	Weighted Average
731		1.80% Pervious Area
39,871		98.20% Impervious Area

Tc (min)	Length (feet)	Slope (ft/ft)	Velocity (ft/sec)	Capacity (cfs)	Description
6.0					Direct Entry,

Subcatchment 9S: Sub 9

Hydrograph

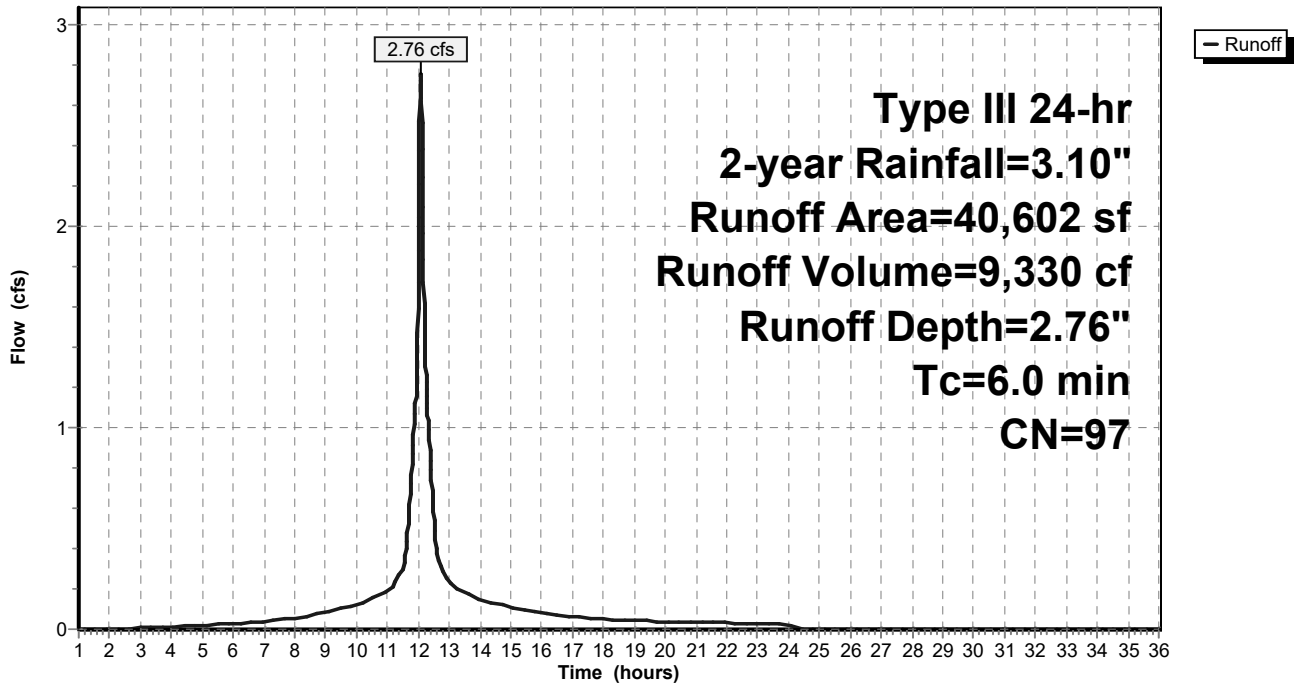

Spofford Pre-Development

Prepared by Weston & Sampson

HydroCAD® 10.10-6a s/n 00455 © 2020 HydroCAD Software Solutions LLC

Type III 24-hr 2-year Rainfall=3.10"

Printed 11/2/2021

Page 16

Summary for Subcatchment 10S: Sub 10

Runoff = 0.55 cfs @ 12.09 hrs, Volume= 1,762 cf, Depth= 1.14"

Routed to Link 4L : Vernal Pool Wetlands

Runoff by SCS TR-20 method, UH=SCS, Weighted-CN, Time Span= 1.00-36.00 hrs, dt= 0.01 hrs
Type III 24-hr 2-year Rainfall=3.10"

Area (sf)	CN	Description
12,797	98	Paved parking, HSG A
424	30	Woods, Good, HSG A
* 5,312	30	Grass
18,533	77	Weighted Average
5,736		30.95% Pervious Area
12,797		69.05% Impervious Area

Tc (min)	Length (feet)	Slope (ft/ft)	Velocity (ft/sec)	Capacity (cfs)	Description
6.0					Direct Entry,

Subcatchment 10S: Sub 10

Hydrograph

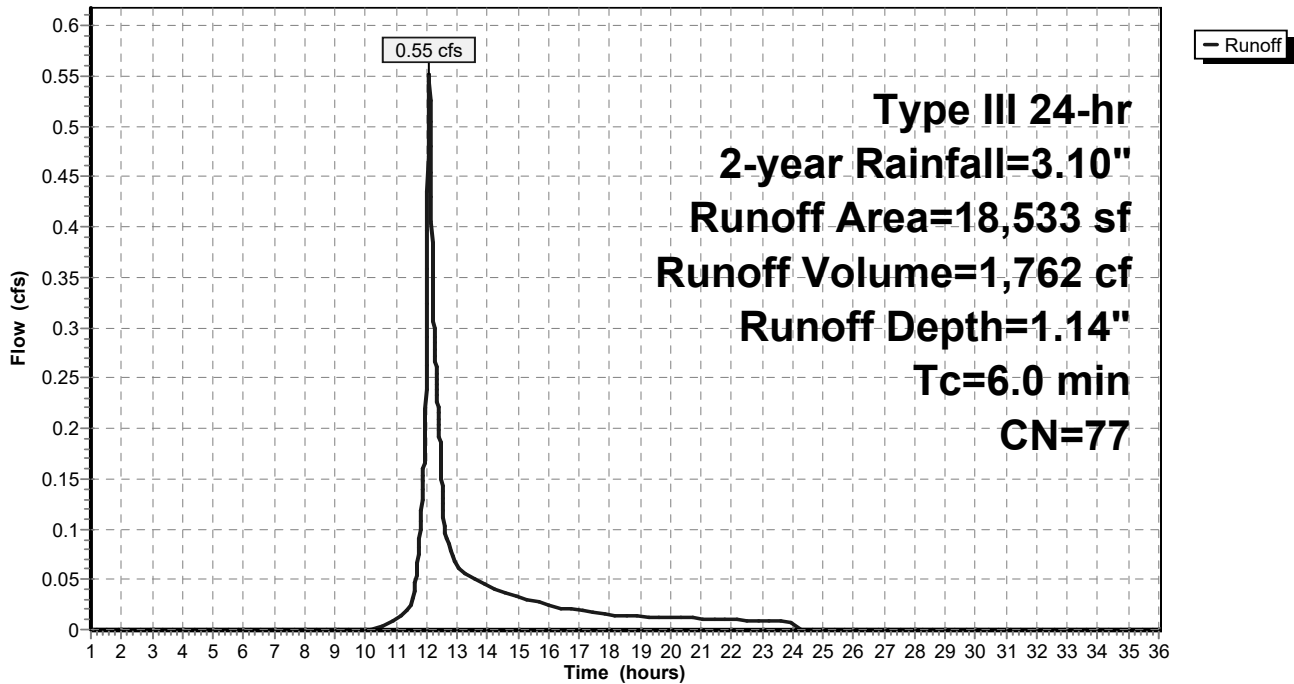

Spofford Pre-Development

Prepared by Weston & Sampson

HydroCAD® 10.10-6a s/n 00455 © 2020 HydroCAD Software Solutions LLC

Type III 24-hr 2-year Rainfall=3.10"

Printed 11/2/2021

Page 17

Summary for Subcatchment 11S: Sub 11

Runoff = 0.95 cfs @ 12.10 hrs, Volume= 3,138 cf, Depth= 0.97"
 Routed to Link 4L : Vernal Pool Wetlands

Runoff by SCS TR-20 method, UH=SCS, Weighted-CN, Time Span= 1.00-36.00 hrs, dt= 0.01 hrs
 Type III 24-hr 2-year Rainfall=3.10"

Area (sf)	CN	Description
5,533	98	Paved parking, HSG A
4,499	30	Woods, Good, HSG A
* 9,450	30	Grass
* 19,248	98	Compacted Gravel
38,730	74	Weighted Average
13,949		36.02% Pervious Area
24,781		63.98% Impervious Area

Tc (min)	Length (feet)	Slope (ft/ft)	Velocity (ft/sec)	Capacity (cfs)	Description
6.0					Direct Entry,

Subcatchment 11S: Sub 11

Hydrograph

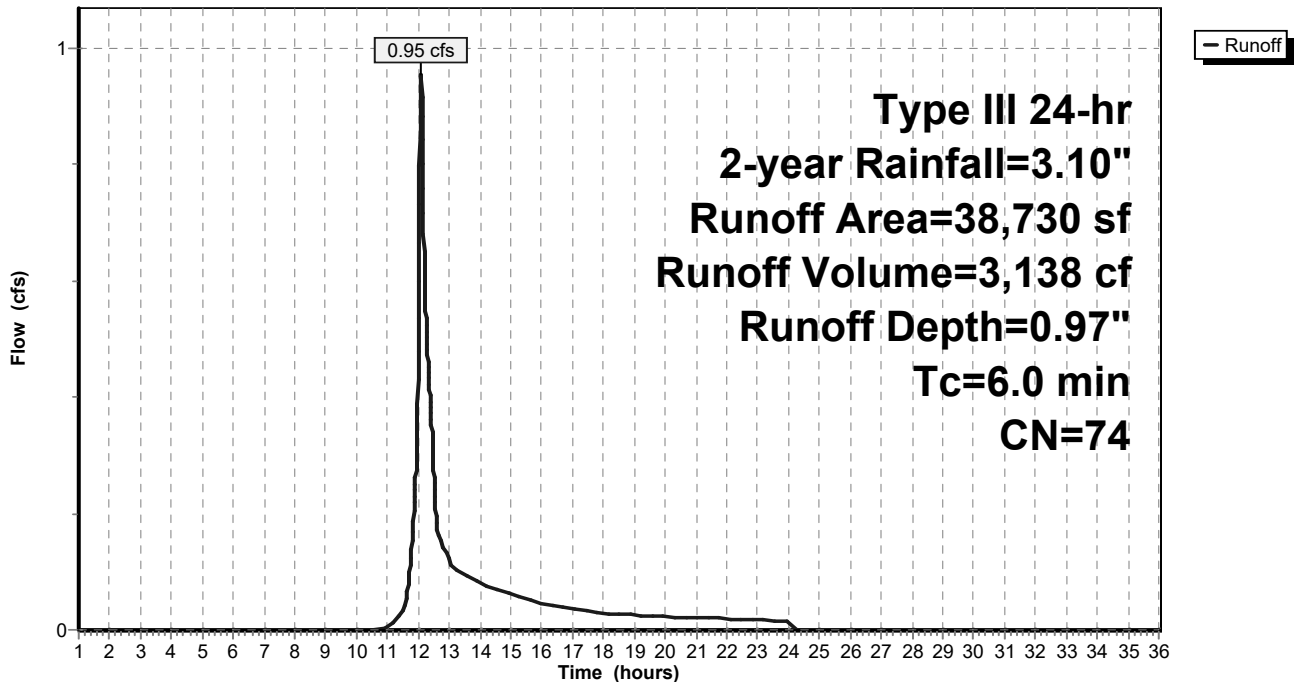

Summary for Link 1L: Leaching CB

Inflow Area = 9,774 sf, 0.00% Impervious, Inflow Depth = 0.00" for 2-year event
Inflow = 0.00 cfs @ 1.00 hrs, Volume= 0 cf
Primary = 0.00 cfs @ 1.00 hrs, Volume= 0 cf, Atten= 0%, Lag= 0.0 min

Primary outflow = Inflow, Time Span= 1.00-36.00 hrs, dt= 0.01 hrs

Link 1L: Leaching CB

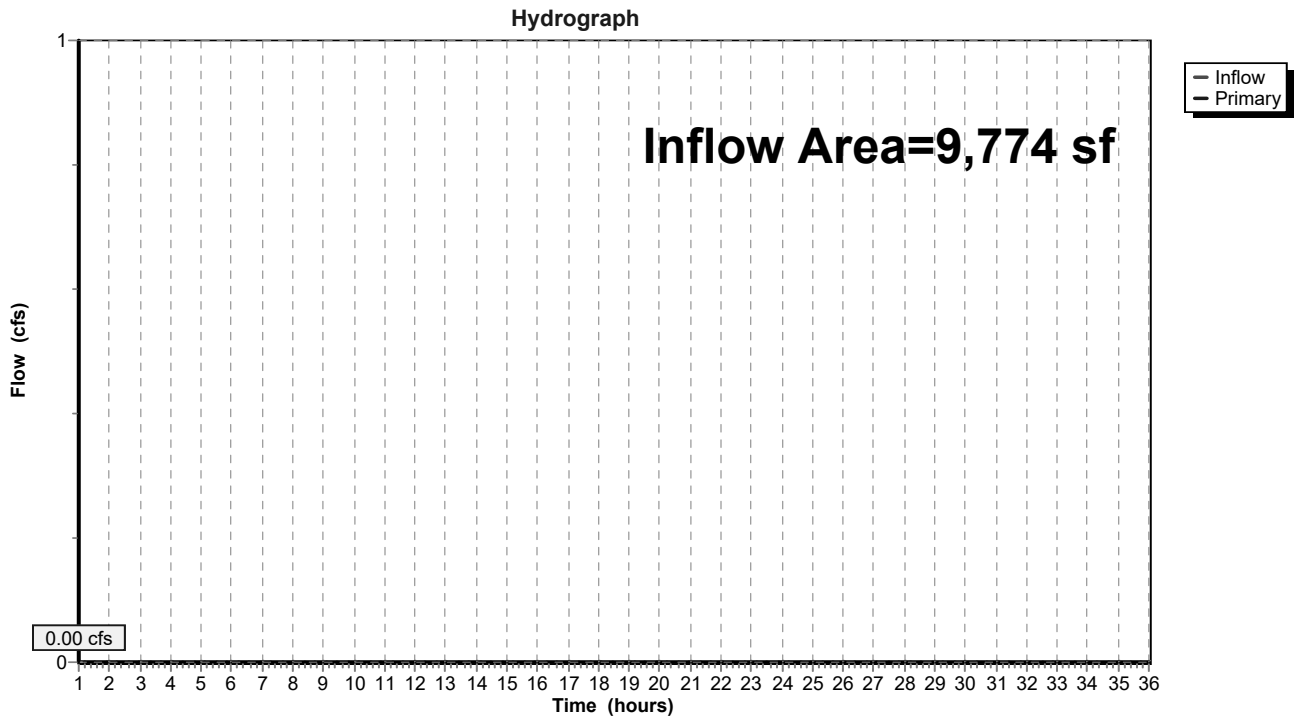

Summary for Link 2L: Isolated Wetlands

Inflow Area = 16,497 sf, 9.02% Impervious, Inflow Depth = 0.00" for 2-year event
Inflow = 0.00 cfs @ 1.00 hrs, Volume= 0 cf
Primary = 0.00 cfs @ 1.00 hrs, Volume= 0 cf, Atten= 0%, Lag= 0.0 min

Primary outflow = Inflow, Time Span= 1.00-36.00 hrs, dt= 0.01 hrs

Link 2L: Isolated Wetlands

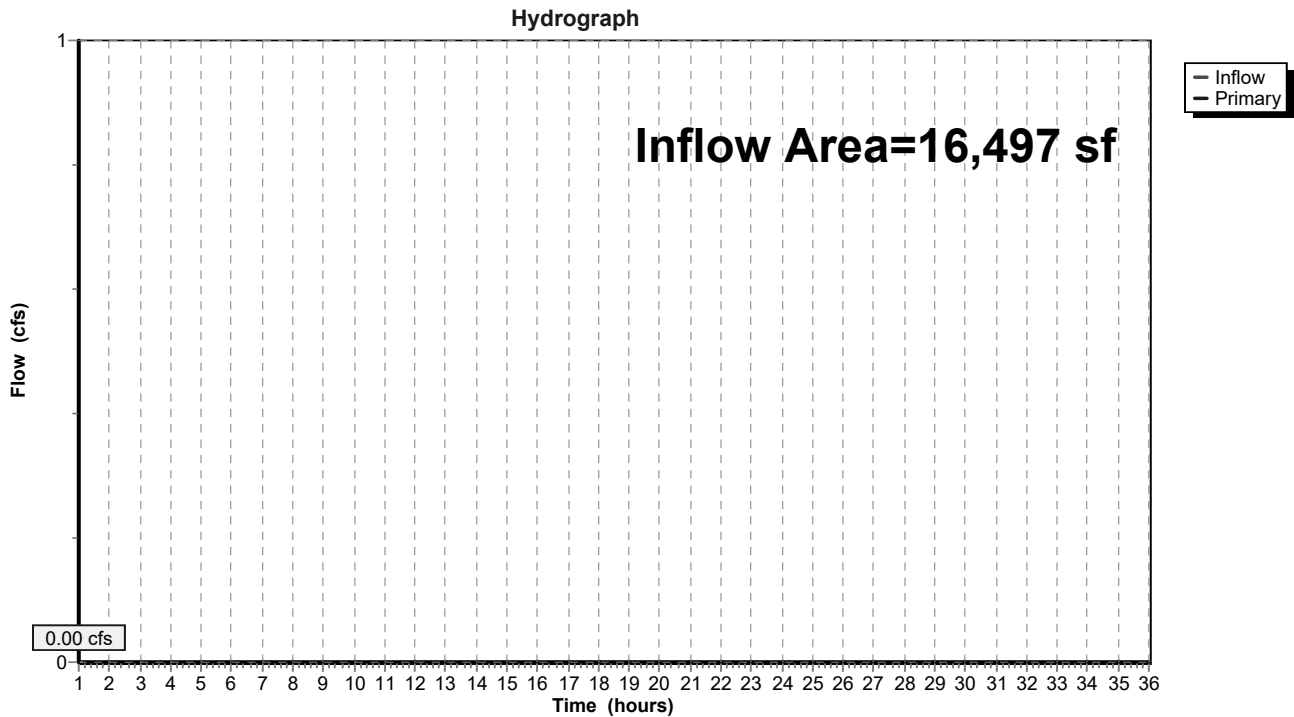

Summary for Link 3L: Spofford Pond Wetlands

Inflow Area = 55,898 sf, 22.84% Impervious, Inflow Depth = 0.04" for 2-year event
Inflow = 0.01 cfs @ 15.42 hrs, Volume= 184 cf
Primary = 0.01 cfs @ 15.42 hrs, Volume= 184 cf, Atten= 0%, Lag= 0.0 min

Primary outflow = Inflow, Time Span= 1.00-36.00 hrs, dt= 0.01 hrs

Link 3L: Spofford Pond Wetlands

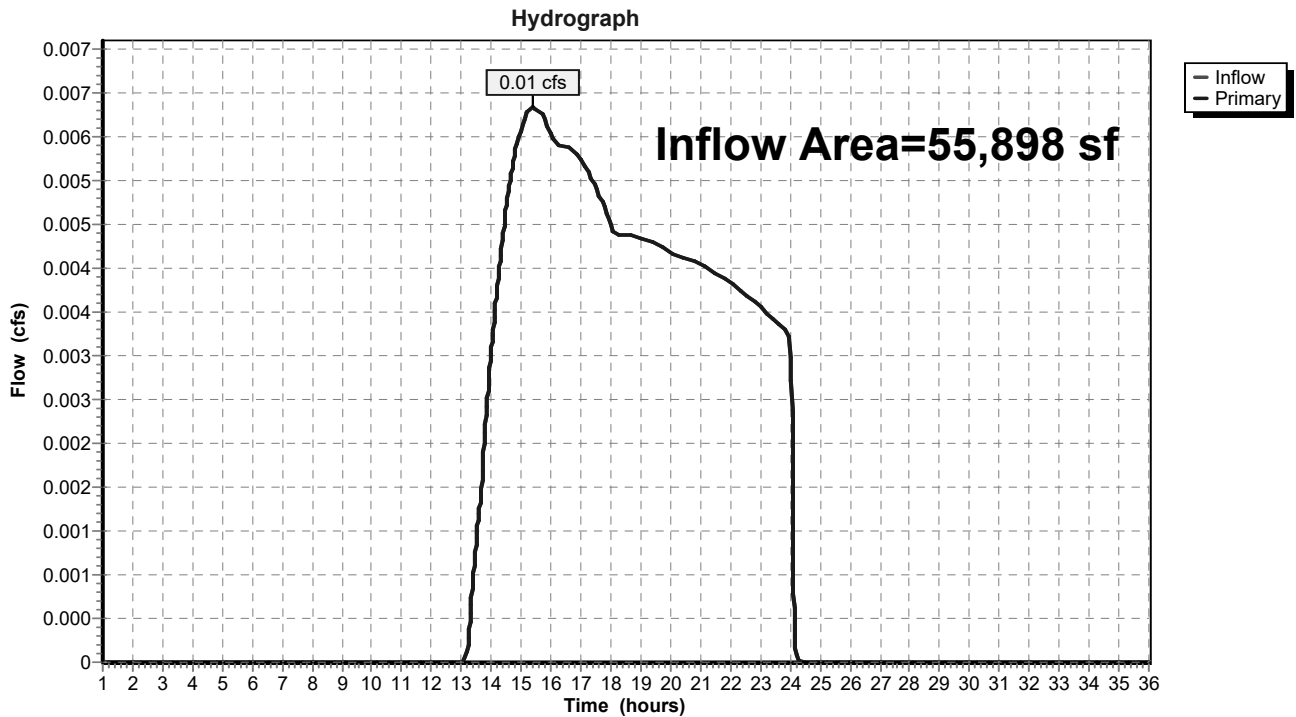

Summary for Link 4L: Vernal Pool Wetlands

Inflow Area = 225,348 sf, 85.58% Impervious, Inflow Depth = 2.08" for 2-year event
Inflow = 11.54 cfs @ 12.09 hrs, Volume= 39,005 cf
Primary = 11.54 cfs @ 12.09 hrs, Volume= 39,005 cf, Atten= 0%, Lag= 0.0 min
Routed to nonexistent node 25L

Primary outflow = Inflow, Time Span= 1.00-36.00 hrs, dt= 0.01 hrs

Link 4L: Vernal Pool Wetlands

Hydrograph

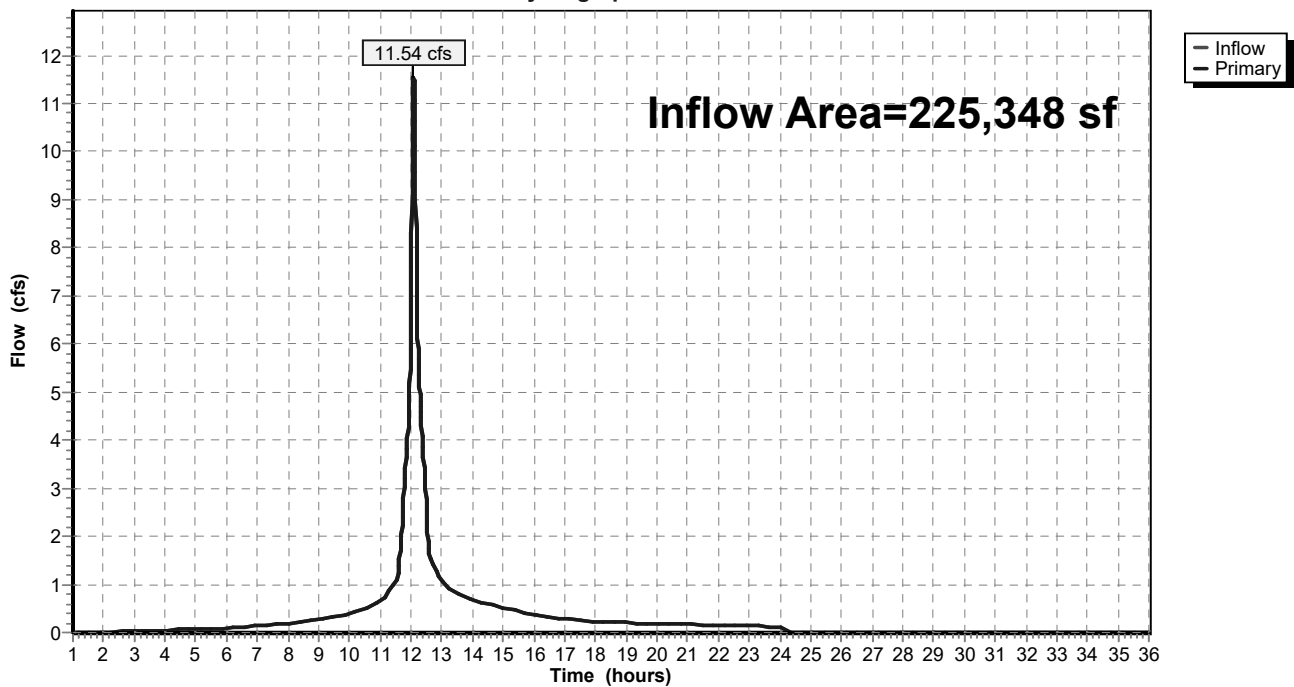

Time span=1.00-36.00 hrs, dt=0.01 hrs, 3501 points
 Runoff by SCS TR-20 method, UH=SCS, Weighted-CN
 Reach routing by Dyn-Stor-Ind method - Pond routing by Dyn-Stor-Ind method

Subcatchment1S: Roof	Runoff Area=71,161 sf 100.00% Impervious Runoff Depth>4.46" Tc=6.0 min CN=98 Runoff=7.51 cfs 26,470 cf
Subcatchment2S: Sub 2	Runoff Area=9,774 sf 0.00% Impervious Runoff Depth=0.00" Tc=6.0 min CN=30 Runoff=0.00 cfs 0 cf
Subcatchment3S: Sub 3	Runoff Area=24,730 sf 73.09% Impervious Runoff Depth=2.63" Tc=6.0 min CN=80 Runoff=1.75 cfs 5,426 cf
Subcatchment4S: Sub 4	Runoff Area=13,456 sf 63.32% Impervious Runoff Depth=2.05" Tc=6.0 min CN=73 Runoff=0.73 cfs 2,296 cf
Subcatchment5S: Sub 5	Runoff Area=28,834 sf 23.36% Impervious Runoff Depth=0.39" Tc=6.0 min CN=46 Runoff=0.11 cfs 943 cf
Subcatchment6S: Sub 6	Runoff Area=27,064 sf 22.29% Impervious Runoff Depth=0.35" Tc=6.0 min CN=45 Runoff=0.09 cfs 793 cf
Subcatchment7S: Sub 7	Runoff Area=18,136 sf 97.29% Impervious Runoff Depth=4.23" Tc=6.0 min CN=96 Runoff=1.88 cfs 6,400 cf
Subcatchment8S: Sub 8	Runoff Area=16,497 sf 9.02% Impervious Runoff Depth=0.07" Tc=6.0 min CN=36 Runoff=0.00 cfs 95 cf
Subcatchment9S: Sub 9	Runoff Area=40,602 sf 98.20% Impervious Runoff Depth=4.35" Tc=6.0 min CN=97 Runoff=4.25 cfs 14,712 cf
Subcatchment10S: Sub 10	Runoff Area=18,533 sf 69.05% Impervious Runoff Depth=2.37" Tc=6.0 min CN=77 Runoff=1.18 cfs 3,667 cf
Subcatchment11S: Sub 11	Runoff Area=38,730 sf 63.98% Impervious Runoff Depth=2.13" Tc=6.0 min CN=74 Runoff=2.20 cfs 6,866 cf
Link 1L: Leaching CB	Inflow=0.00 cfs 0 cf Primary=0.00 cfs 0 cf
Link 2L: Isolated Wetlands	Inflow=0.00 cfs 95 cf Primary=0.00 cfs 95 cf
Link 3L: Spofford Pond Wetlands	Inflow=0.20 cfs 1,736 cf Primary=0.20 cfs 1,736 cf
Link 4L: Vernal Pool Wetlands	Inflow=19.49 cfs 65,836 cf Primary=19.49 cfs 65,836 cf

Total Runoff Area = 307,517 sf Runoff Volume = 67,668 cf Average Runoff Depth = 2.64"
32.65% Pervious = 100,409 sf 67.35% Impervious = 207,108 sf

Spofford Pre-Development

Prepared by Weston & Sampson

HydroCAD® 10.10-6a s/n 00455 © 2020 HydroCAD Software Solutions LLC

Type III 24-hr 10-year Rainfall=4.70"

Printed 11/2/2021

Page 23

Summary for Subcatchment 1S: Roof

Runoff = 7.51 cfs @ 12.08 hrs, Volume= 26,470 cf, Depth> 4.46"

Routed to Link 4L : Vernal Pool Wetlands

Runoff by SCS TR-20 method, UH=SCS, Weighted-CN, Time Span= 1.00-36.00 hrs, dt= 0.01 hrs
Type III 24-hr 10-year Rainfall=4.70"

Area (sf)	CN	Description
71,161	98	Roofs, HSG A
71,161		100.00% Impervious Area

Tc (min)	Length (feet)	Slope (ft/ft)	Velocity (ft/sec)	Capacity (cfs)	Description
6.0					Direct Entry,

Subcatchment 1S: Roof

Hydrograph

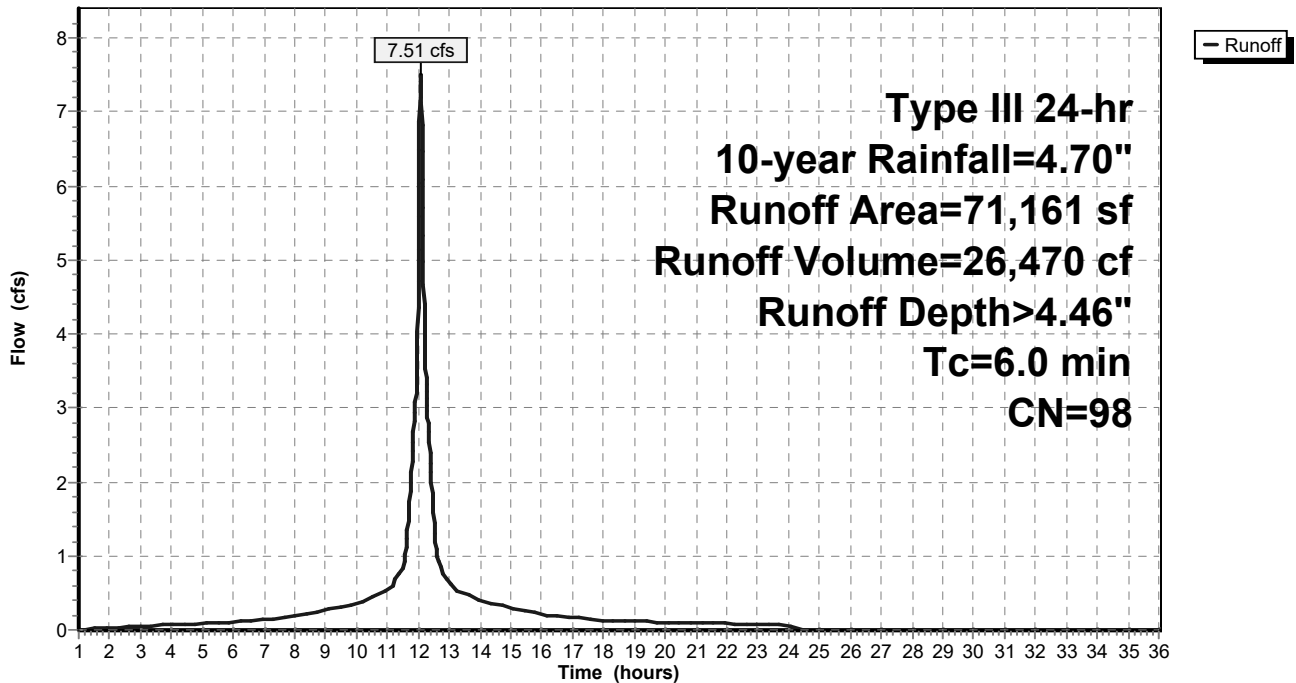

Spofford Pre-Development

Prepared by Weston & Sampson

HydroCAD® 10.10-6a s/n 00455 © 2020 HydroCAD Software Solutions LLC

Type III 24-hr 10-year Rainfall=4.70"

Printed 11/2/2021

Page 24

Summary for Subcatchment 2S: Sub 2

Runoff = 0.00 cfs @ 24.02 hrs, Volume= 0 cf, Depth= 0.00"

Routed to Link 1L : Leaching CB

Runoff by SCS TR-20 method, UH=SCS, Weighted-CN, Time Span= 1.00-36.00 hrs, dt= 0.01 hrs
Type III 24-hr 10-year Rainfall=4.70"

Area (sf)	CN	Description
* 9,774	30	Grass
9,774		100.00% Pervious Area

Tc (min)	Length (feet)	Slope (ft/ft)	Velocity (ft/sec)	Capacity (cfs)	Description
6.0					Direct Entry,

Subcatchment 2S: Sub 2

Hydrograph

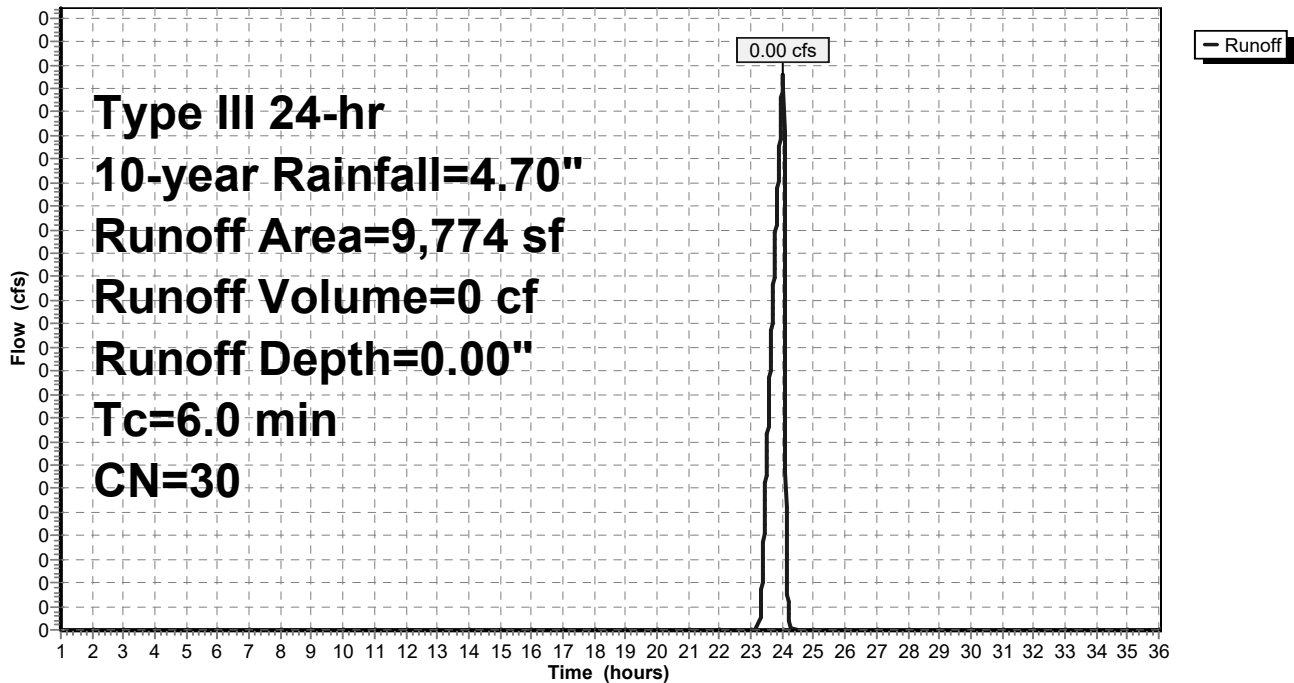

Spofford Pre-Development

Prepared by Weston & Sampson

HydroCAD® 10.10-6a s/n 00455 © 2020 HydroCAD Software Solutions LLC

Type III 24-hr 10-year Rainfall=4.70"

Printed 11/2/2021

Page 25

Summary for Subcatchment 3S: Sub 3

Runoff = 1.75 cfs @ 12.09 hrs, Volume= 5,426 cf, Depth= 2.63"
 Routed to Link 4L : Vernal Pool Wetlands

Runoff by SCS TR-20 method, UH=SCS, Weighted-CN, Time Span= 1.00-36.00 hrs, dt= 0.01 hrs
 Type III 24-hr 10-year Rainfall=4.70"

Area (sf)	CN	Description
8,972	98	Paved parking, HSG A
* 9,104	98	Turf (impervious)
* 5,760	30	Grass
894	30	Woods, Good, HSG A
24,730	80	Weighted Average
6,654		26.91% Pervious Area
18,076		73.09% Impervious Area

Tc (min)	Length (feet)	Slope (ft/ft)	Velocity (ft/sec)	Capacity (cfs)	Description
6.0					Direct Entry,

Subcatchment 3S: Sub 3

Hydrograph

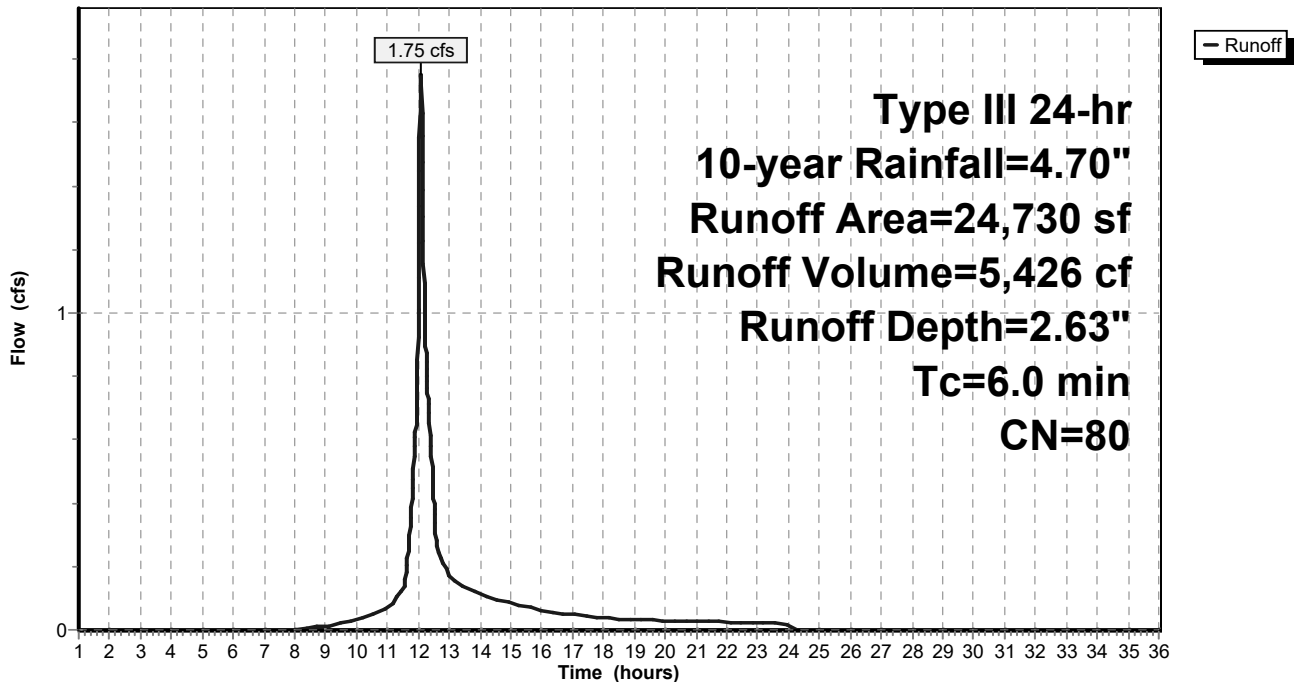

Spofford Pre-Development

Prepared by Weston & Sampson

HydroCAD® 10.10-6a s/n 00455 © 2020 HydroCAD Software Solutions LLC

Type III 24-hr 10-year Rainfall=4.70"

Printed 11/2/2021

Page 26

Summary for Subcatchment 4S: Sub 4

Runoff = 0.73 cfs @ 12.09 hrs, Volume= 2,296 cf, Depth= 2.05"
 Routed to Link 4L : Vernal Pool Wetlands

Runoff by SCS TR-20 method, UH=SCS, Weighted-CN, Time Span= 1.00-36.00 hrs, dt= 0.01 hrs
 Type III 24-hr 10-year Rainfall=4.70"

Area (sf)	CN	Description
8,521	98	Paved parking, HSG A
2,064	30	Woods, Good, HSG A
* 2,871	30	Grass
13,456	73	Weighted Average
4,935		36.68% Pervious Area
8,521		63.32% Impervious Area

Tc (min)	Length (feet)	Slope (ft/ft)	Velocity (ft/sec)	Capacity (cfs)	Description
6.0					Direct Entry,

Subcatchment 4S: Sub 4

Hydrograph

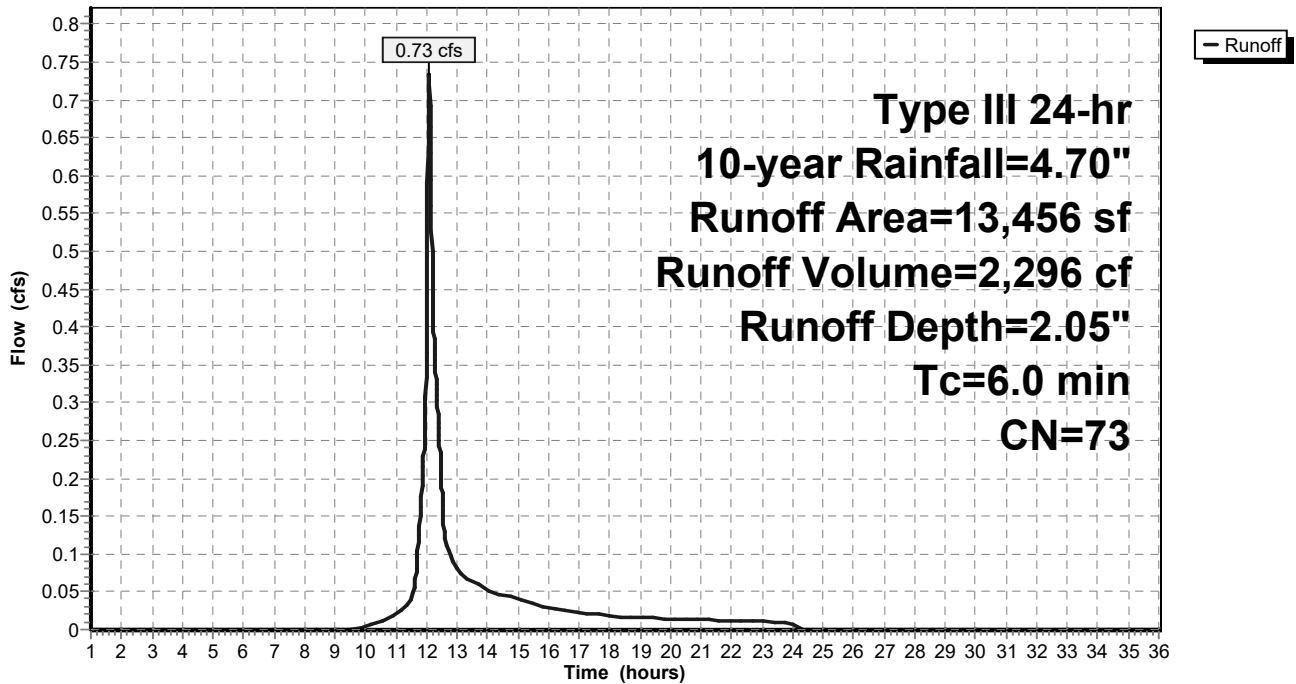

Summary for Subcatchment 5S: Sub 5

Runoff = 0.11 cfs @ 12.32 hrs, Volume= 943 cf, Depth= 0.39"
 Routed to Link 3L : Spofford Pond Wetlands

Runoff by SCS TR-20 method, UH=SCS, Weighted-CN, Time Span= 1.00-36.00 hrs, dt= 0.01 hrs
 Type III 24-hr 10-year Rainfall=4.70"

Area (sf)	CN	Description
6,737	98	Paved parking, HSG A
9,957	30	Woods, Good, HSG A
* 12,140	30	Grass
28,834	46	Weighted Average
22,097		76.64% Pervious Area
6,737		23.36% Impervious Area

Tc (min)	Length (feet)	Slope (ft/ft)	Velocity (ft/sec)	Capacity (cfs)	Description
6.0					Direct Entry,

Subcatchment 5S: Sub 5

Hydrograph

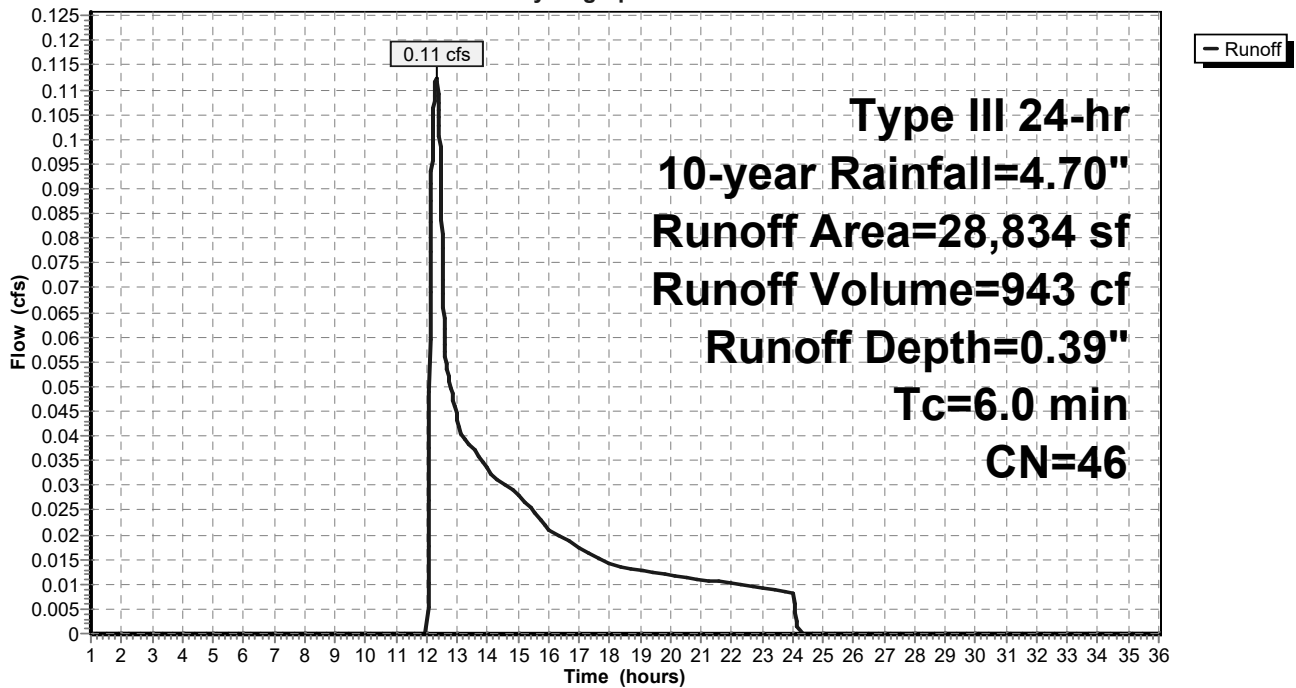

Summary for Subcatchment 6S: Sub 6

Runoff = 0.09 cfs @ 12.34 hrs, Volume= 793 cf, Depth= 0.35"
 Routed to Link 3L : Spofford Pond Wetlands

Runoff by SCS TR-20 method, UH=SCS, Weighted-CN, Time Span= 1.00-36.00 hrs, dt= 0.01 hrs
 Type III 24-hr 10-year Rainfall=4.70"

Area (sf)	CN	Description
6,032	98	Paved parking, HSG A
* 21,032	30	Grass
27,064	45	Weighted Average
21,032		77.71% Pervious Area
6,032		22.29% Impervious Area

Tc (min)	Length (feet)	Slope (ft/ft)	Velocity (ft/sec)	Capacity (cfs)	Description
6.0					Direct Entry,

Subcatchment 6S: Sub 6

Hydrograph

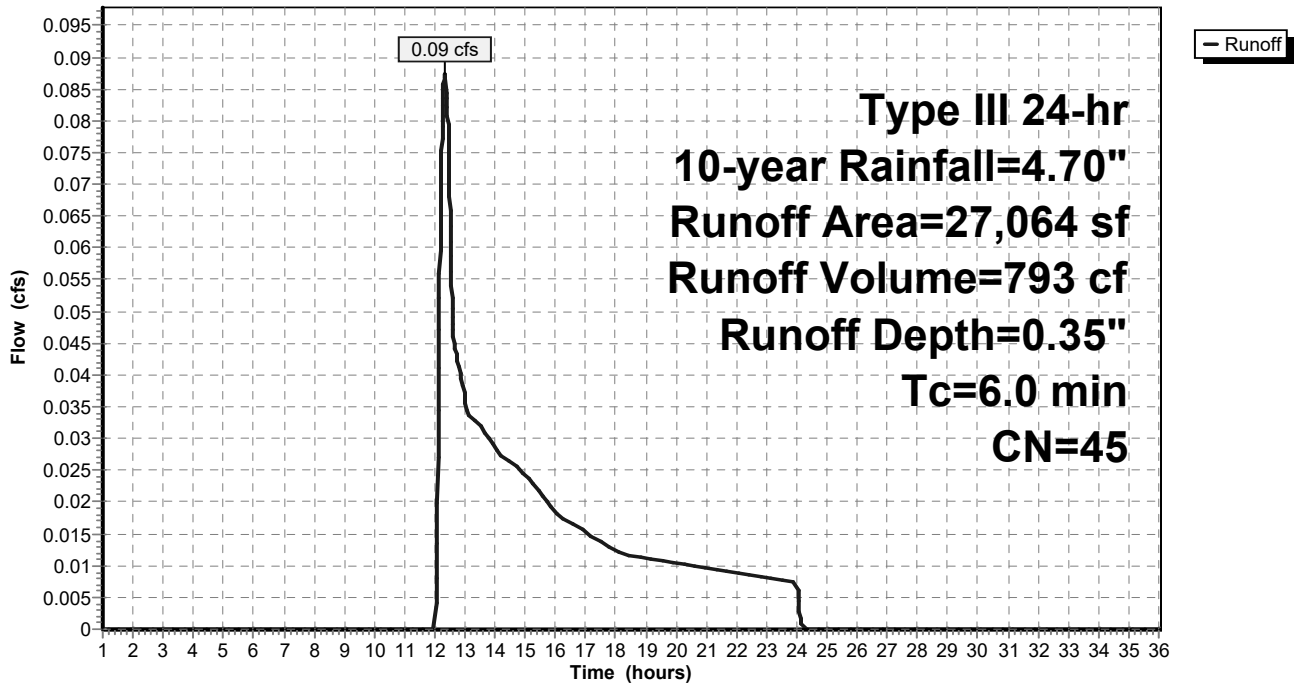

Spofford Pre-Development

Prepared by Weston & Sampson

HydroCAD® 10.10-6a s/n 00455 © 2020 HydroCAD Software Solutions LLC

Type III 24-hr 10-year Rainfall=4.70"

Printed 11/2/2021

Page 29

Summary for Subcatchment 7S: Sub 7

Runoff = 1.88 cfs @ 12.08 hrs, Volume= 6,400 cf, Depth= 4.23"
Routed to Link 4L : Vernal Pool Wetlands

Runoff by SCS TR-20 method, UH=SCS, Weighted-CN, Time Span= 1.00-36.00 hrs, dt= 0.01 hrs
Type III 24-hr 10-year Rainfall=4.70"

Area (sf)	CN	Description
17,644	98	Paved parking, HSG A
* 492	30	Grass
18,136	96	Weighted Average
492		2.71% Pervious Area
17,644		97.29% Impervious Area

Tc (min)	Length (feet)	Slope (ft/ft)	Velocity (ft/sec)	Capacity (cfs)	Description
6.0					Direct Entry,

Subcatchment 7S: Sub 7

Hydrograph

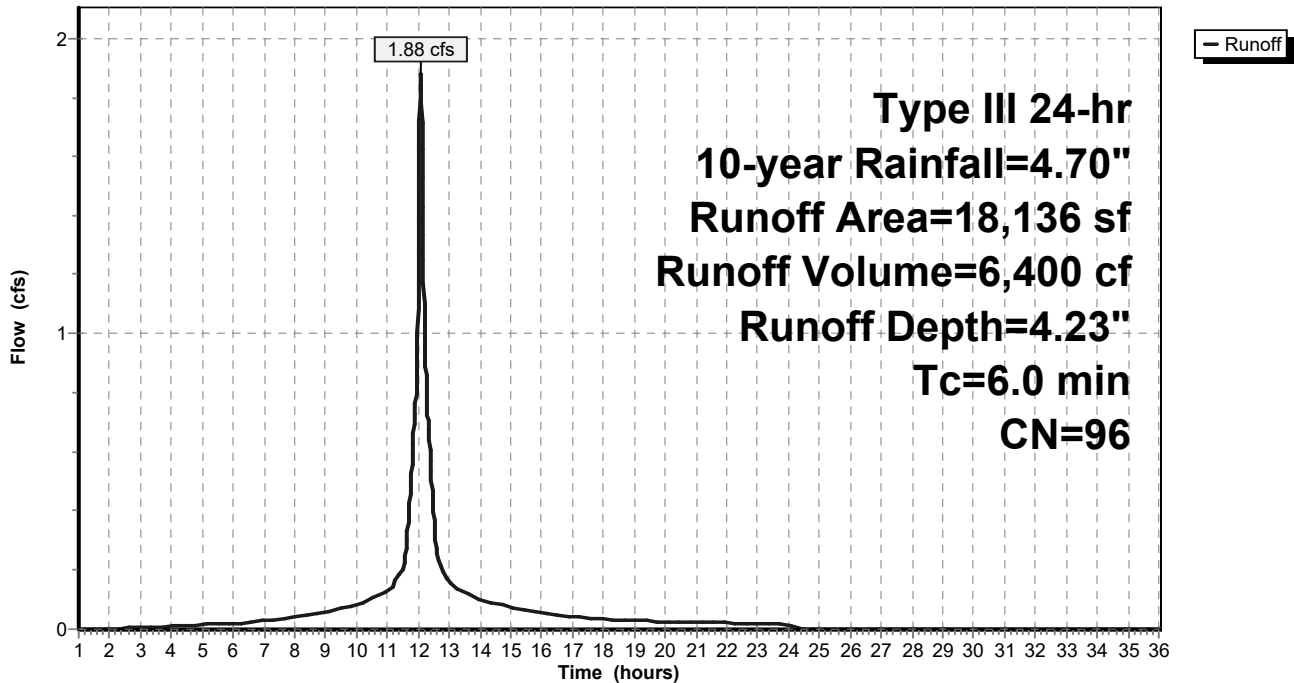

Summary for Subcatchment 8S: Sub 8

Runoff = 0.00 cfs @ 15.26 hrs, Volume= 95 cf, Depth= 0.07"
 Routed to Link 2L : Isolated Wetlands

Runoff by SCS TR-20 method, UH=SCS, Weighted-CN, Time Span= 1.00-36.00 hrs, dt= 0.01 hrs
 Type III 24-hr 10-year Rainfall=4.70"

Area (sf)	CN	Description
1,488	98	Paved parking, HSG A
* 15,009	30	Grass
16,497	36	Weighted Average
15,009		90.98% Pervious Area
1,488		9.02% Impervious Area

Tc (min)	Length (feet)	Slope (ft/ft)	Velocity (ft/sec)	Capacity (cfs)	Description
6.0					Direct Entry,

Subcatchment 8S: Sub 8

Hydrograph

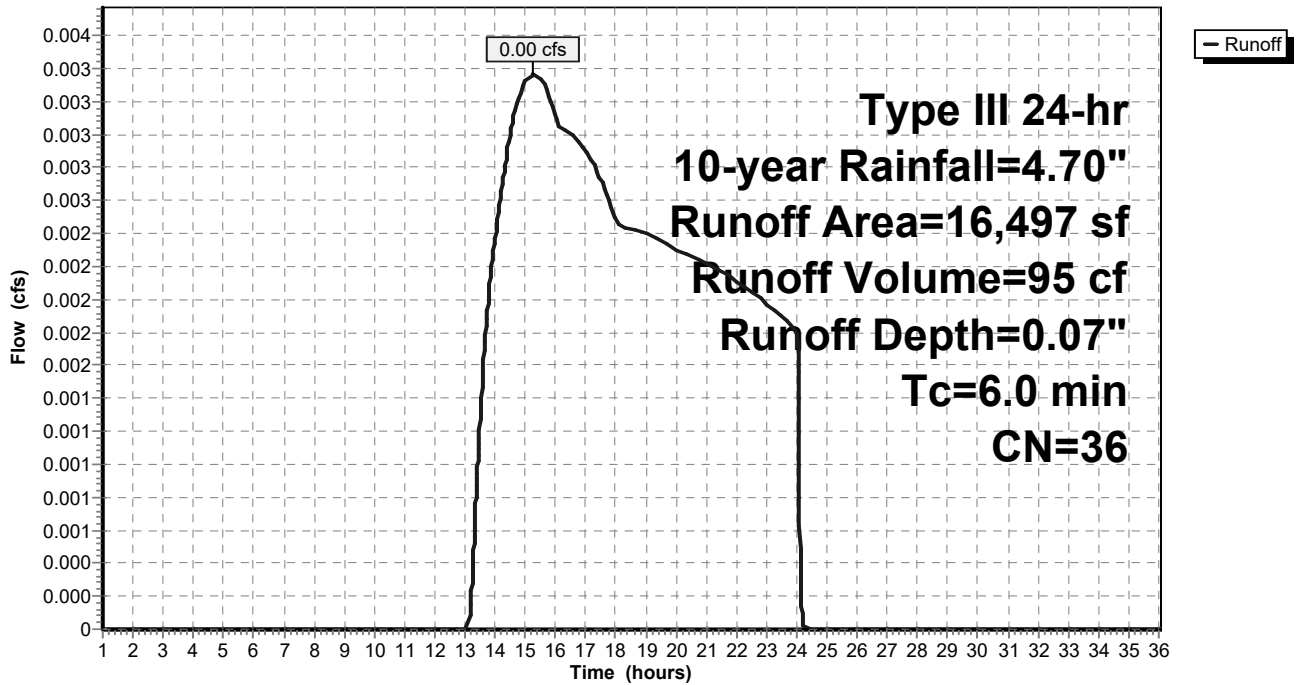

Spofford Pre-Development

Prepared by Weston & Sampson

HydroCAD® 10.10-6a s/n 00455 © 2020 HydroCAD Software Solutions LLC

Type III 24-hr 10-year Rainfall=4.70"

Printed 11/2/2021

Page 31

Summary for Subcatchment 9S: Sub 9

Runoff = 4.25 cfs @ 12.08 hrs, Volume= 14,712 cf, Depth= 4.35"
Routed to Link 4L : Vernal Pool Wetlands

Runoff by SCS TR-20 method, UH=SCS, Weighted-CN, Time Span= 1.00-36.00 hrs, dt= 0.01 hrs
Type III 24-hr 10-year Rainfall=4.70"

Area (sf)	CN	Description
39,871	98	Paved parking, HSG A
* 731	30	Grass
40,602	97	Weighted Average
731		1.80% Pervious Area
39,871		98.20% Impervious Area

Tc (min)	Length (feet)	Slope (ft/ft)	Velocity (ft/sec)	Capacity (cfs)	Description
6.0					Direct Entry,

Subcatchment 9S: Sub 9

Hydrograph

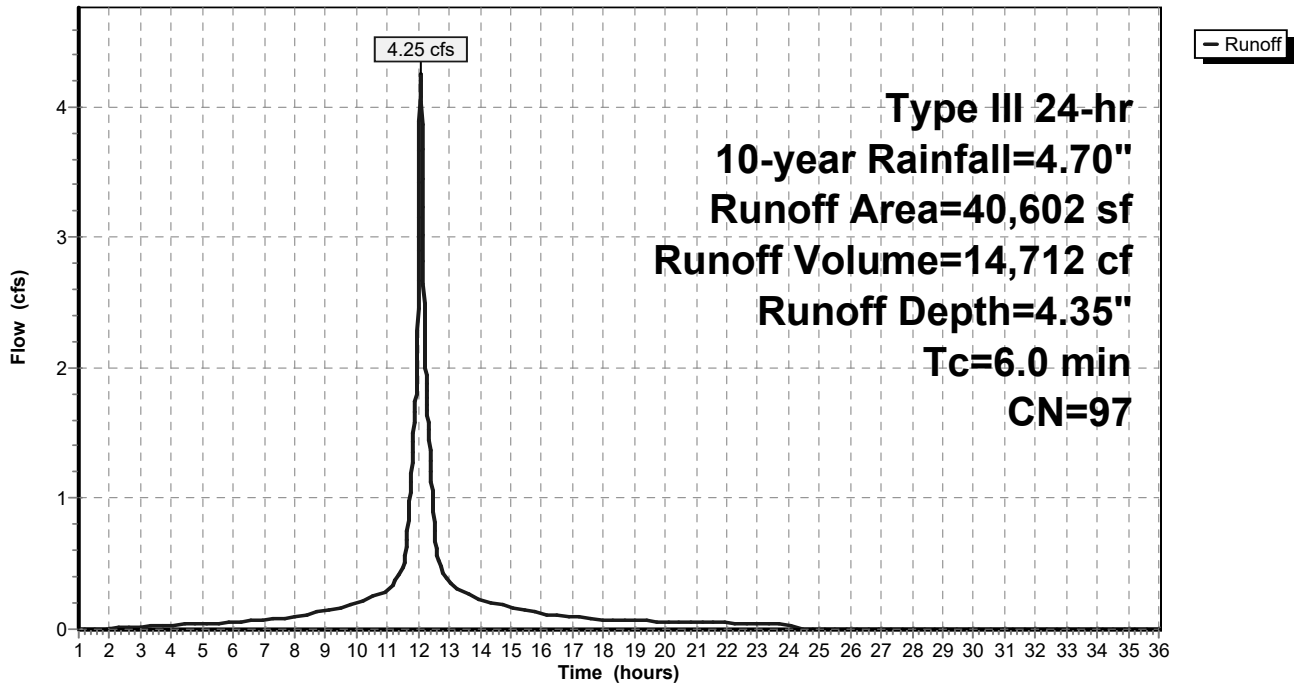

Spofford Pre-Development

Prepared by Weston & Sampson

HydroCAD® 10.10-6a s/n 00455 © 2020 HydroCAD Software Solutions LLC

Type III 24-hr 10-year Rainfall=4.70"

Printed 11/2/2021

Page 32

Summary for Subcatchment 10S: Sub 10

Runoff = 1.18 cfs @ 12.09 hrs, Volume= 3,667 cf, Depth= 2.37"

Routed to Link 4L : Vernal Pool Wetlands

Runoff by SCS TR-20 method, UH=SCS, Weighted-CN, Time Span= 1.00-36.00 hrs, dt= 0.01 hrs
Type III 24-hr 10-year Rainfall=4.70"

Area (sf)	CN	Description
12,797	98	Paved parking, HSG A
424	30	Woods, Good, HSG A
* 5,312	30	Grass
18,533	77	Weighted Average
5,736		30.95% Pervious Area
12,797		69.05% Impervious Area

Tc (min)	Length (feet)	Slope (ft/ft)	Velocity (ft/sec)	Capacity (cfs)	Description
6.0					Direct Entry,

Subcatchment 10S: Sub 10

Hydrograph

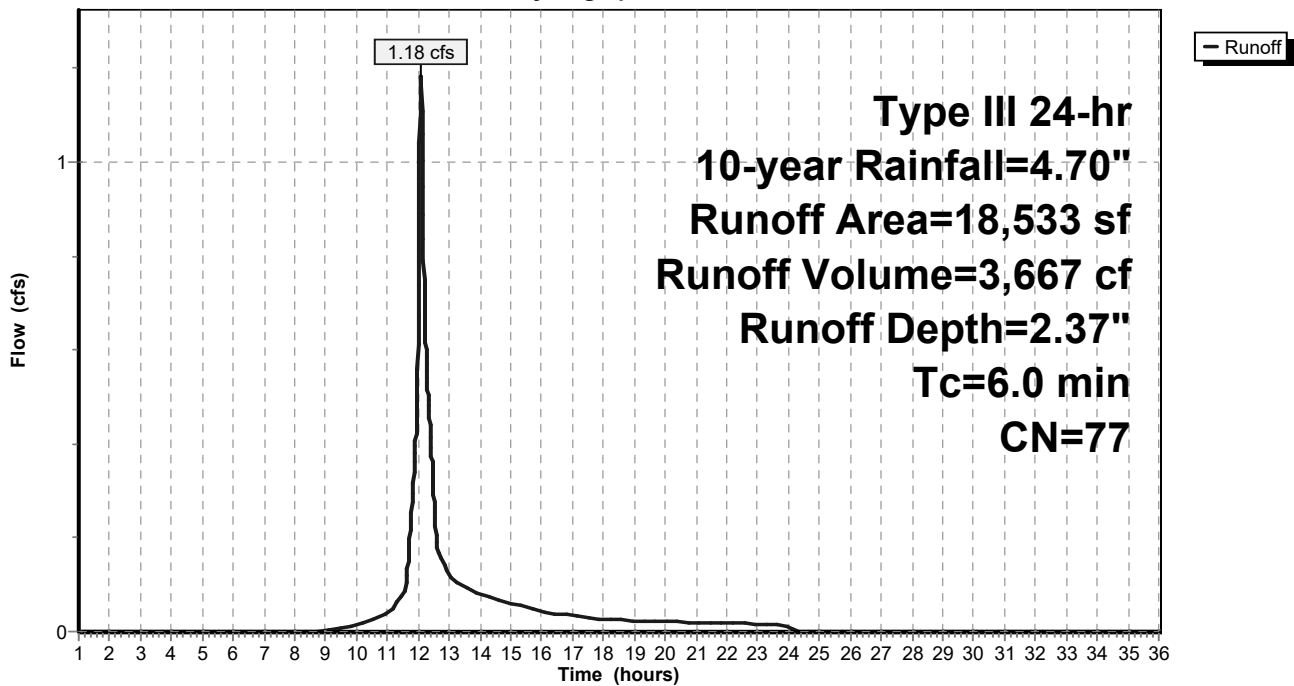

Spofford Pre-Development

Prepared by Weston & Sampson

HydroCAD® 10.10-6a s/n 00455 © 2020 HydroCAD Software Solutions LLC

Type III 24-hr 10-year Rainfall=4.70"

Printed 11/2/2021

Page 33

Summary for Subcatchment 11S: Sub 11

Runoff = 2.20 cfs @ 12.09 hrs, Volume= 6,866 cf, Depth= 2.13"
 Routed to Link 4L : Vernal Pool Wetlands

Runoff by SCS TR-20 method, UH=SCS, Weighted-CN, Time Span= 1.00-36.00 hrs, dt= 0.01 hrs
 Type III 24-hr 10-year Rainfall=4.70"

Area (sf)	CN	Description
5,533	98	Paved parking, HSG A
4,499	30	Woods, Good, HSG A
* 9,450	30	Grass
* 19,248	98	Compacted Gravel
38,730	74	Weighted Average
13,949		36.02% Pervious Area
24,781		63.98% Impervious Area

Tc (min)	Length (feet)	Slope (ft/ft)	Velocity (ft/sec)	Capacity (cfs)	Description
6.0					Direct Entry,

Subcatchment 11S: Sub 11

Hydrograph

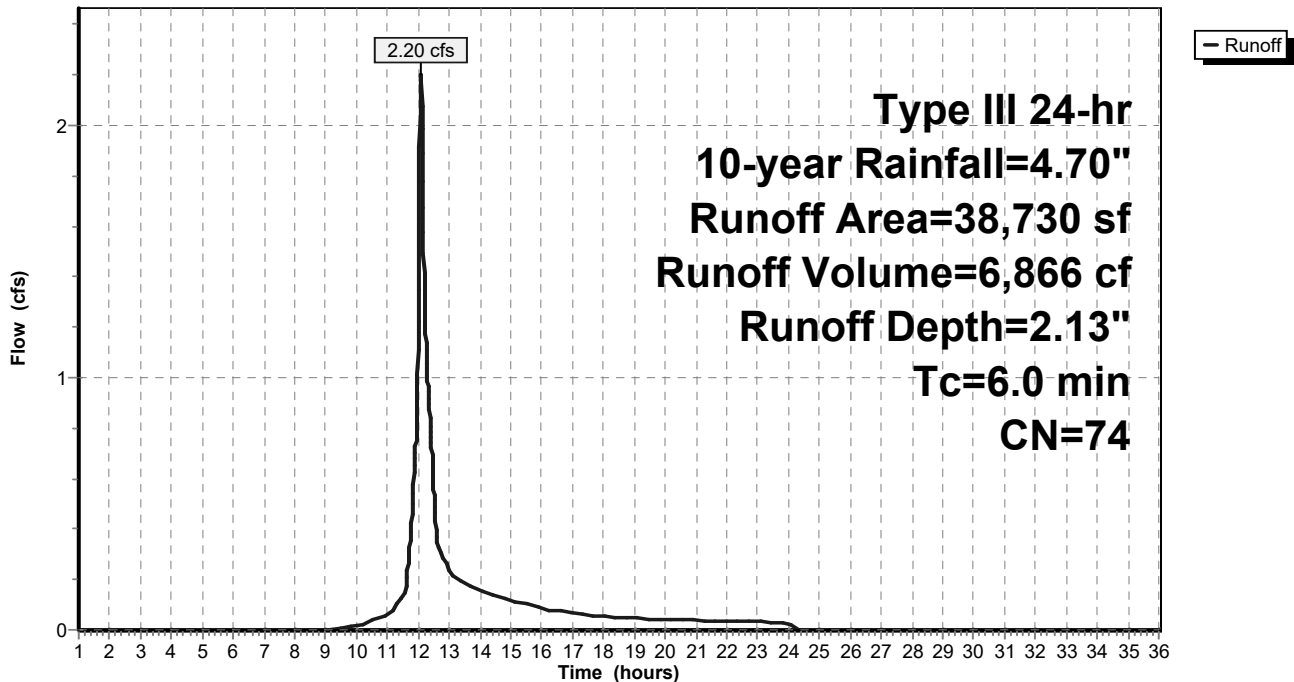

Summary for Link 1L: Leaching CB

Inflow Area = 9,774 sf, 0.00% Impervious, Inflow Depth = 0.00" for 10-year event
Inflow = 0.00 cfs @ 24.02 hrs, Volume= 0 cf
Primary = 0.00 cfs @ 24.02 hrs, Volume= 0 cf, Atten= 0%, Lag= 0.0 min

Primary outflow = Inflow, Time Span= 1.00-36.00 hrs, dt= 0.01 hrs

Link 1L: Leaching CB

Hydrograph

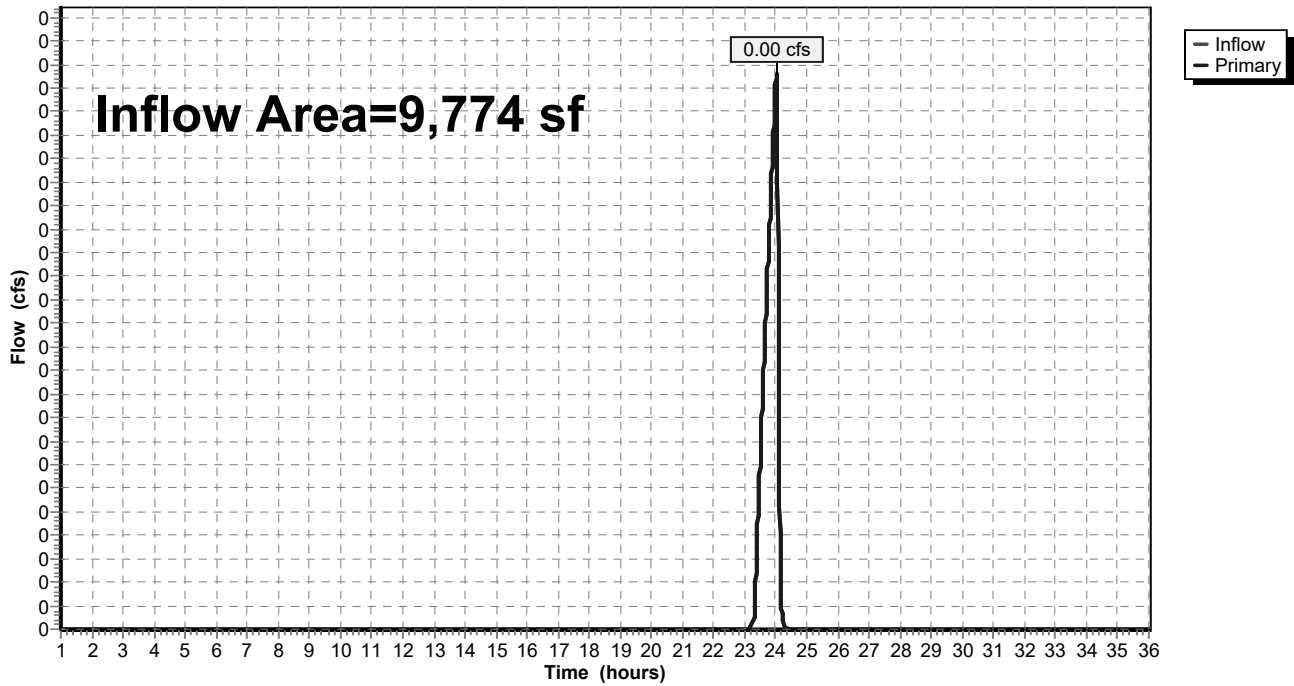

Summary for Link 2L: Isolated Wetlands

Inflow Area = 16,497 sf, 9.02% Impervious, Inflow Depth = 0.07" for 10-year event
Inflow = 0.00 cfs @ 15.26 hrs, Volume= 95 cf
Primary = 0.00 cfs @ 15.26 hrs, Volume= 95 cf, Atten= 0%, Lag= 0.0 min

Primary outflow = Inflow, Time Span= 1.00-36.00 hrs, dt= 0.01 hrs

Link 2L: Isolated Wetlands

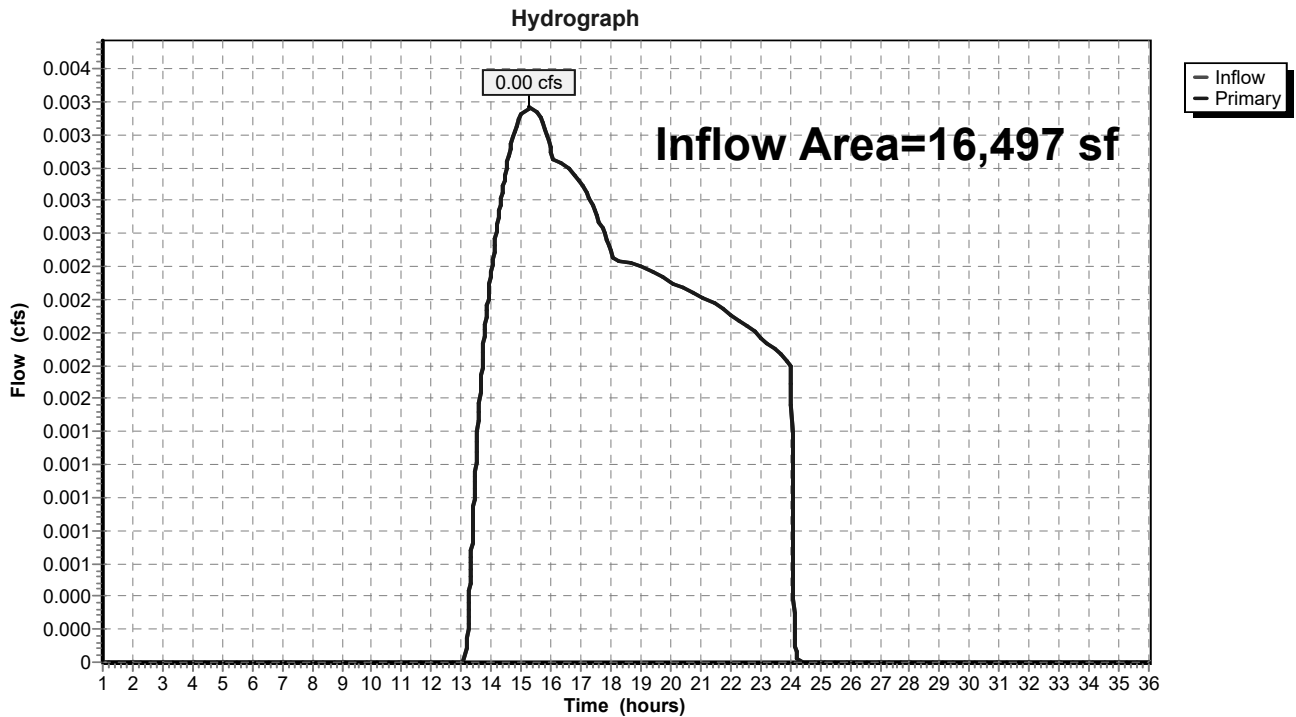

Summary for Link 3L: Spofford Pond Wetlands

Inflow Area = 55,898 sf, 22.84% Impervious, Inflow Depth = 0.37" for 10-year event
Inflow = 0.20 cfs @ 12.33 hrs, Volume= 1,736 cf
Primary = 0.20 cfs @ 12.33 hrs, Volume= 1,736 cf, Atten= 0%, Lag= 0.0 min

Primary outflow = Inflow, Time Span= 1.00-36.00 hrs, dt= 0.01 hrs

Link 3L: Spofford Pond Wetlands

Hydrograph

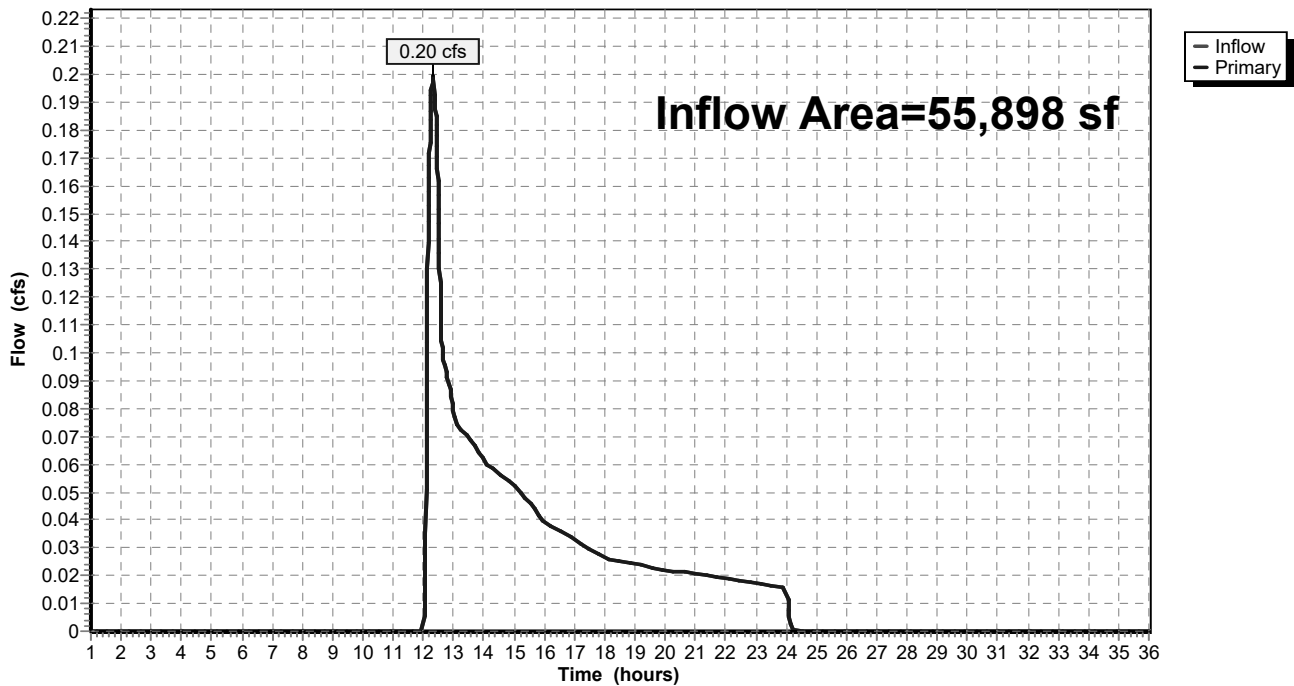

Summary for Link 4L: Vernal Pool Wetlands

Inflow Area = 225,348 sf, 85.58% Impervious, Inflow Depth > 3.51" for 10-year event
Inflow = 19.49 cfs @ 12.09 hrs, Volume= 65,836 cf
Primary = 19.49 cfs @ 12.09 hrs, Volume= 65,836 cf, Atten= 0%, Lag= 0.0 min
Routed to nonexistent node 25L

Primary outflow = Inflow, Time Span= 1.00-36.00 hrs, dt= 0.01 hrs

Link 4L: Vernal Pool Wetlands

Hydrograph

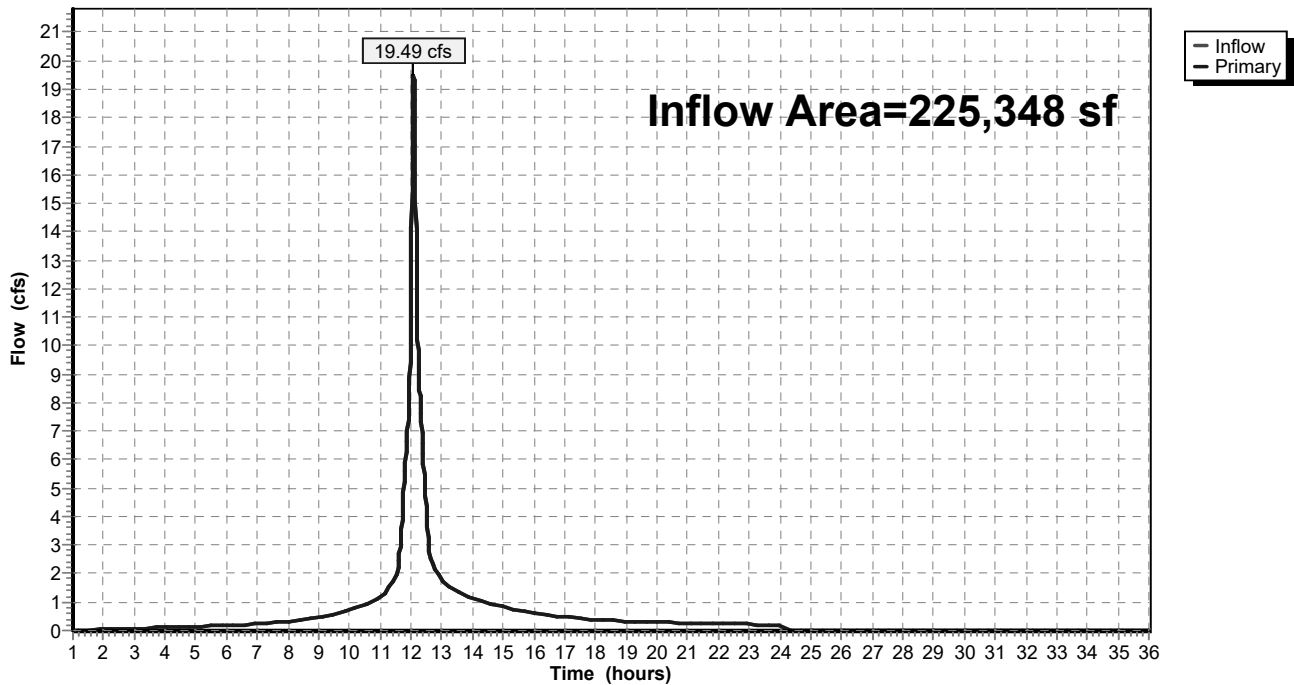

Time span=1.00-36.00 hrs, dt=0.01 hrs, 3501 points
Runoff by SCS TR-20 method, UH=SCS, Weighted-CN
Reach routing by Dyn-Stor-Ind method - Pond routing by Dyn-Stor-Ind method

Subcatchment1S: Roof	Runoff Area=71,161 sf 100.00% Impervious Runoff Depth=5.56" Tc=6.0 min CN=98 Runoff=9.28 cfs 32,980 cf
Subcatchment2S: Sub 2	Runoff Area=9,774 sf 0.00% Impervious Runoff Depth=0.05" Tc=6.0 min CN=30 Runoff=0.00 cfs 43 cf
Subcatchment3S: Sub 3	Runoff Area=24,730 sf 73.09% Impervious Runoff Depth=3.60" Tc=6.0 min CN=80 Runoff=2.39 cfs 7,422 cf
Subcatchment4S: Sub 4	Runoff Area=13,456 sf 63.32% Impervious Runoff Depth=2.92" Tc=6.0 min CN=73 Runoff=1.06 cfs 3,278 cf
Subcatchment5S: Sub 5	Runoff Area=28,834 sf 23.36% Impervious Runoff Depth=0.78" Tc=6.0 min CN=46 Runoff=0.37 cfs 1,885 cf
Subcatchment6S: Sub 6	Runoff Area=27,064 sf 22.29% Impervious Runoff Depth=0.72" Tc=6.0 min CN=45 Runoff=0.29 cfs 1,630 cf
Subcatchment7S: Sub 7	Runoff Area=18,136 sf 97.29% Impervious Runoff Depth=5.33" Tc=6.0 min CN=96 Runoff=2.34 cfs 8,053 cf
Subcatchment8S: Sub 8	Runoff Area=16,497 sf 9.02% Impervious Runoff Depth=0.25" Tc=6.0 min CN=36 Runoff=0.02 cfs 346 cf
Subcatchment9S: Sub 9	Runoff Area=40,602 sf 98.20% Impervious Runoff Depth=5.44" Tc=6.0 min CN=97 Runoff=5.27 cfs 18,422 cf
Subcatchment10S: Sub 10	Runoff Area=18,533 sf 69.05% Impervious Runoff Depth=3.31" Tc=6.0 min CN=77 Runoff=1.65 cfs 5,104 cf
Subcatchment11S: Sub 11	Runoff Area=38,730 sf 63.98% Impervious Runoff Depth=3.02" Tc=6.0 min CN=74 Runoff=3.15 cfs 9,739 cf
Link 1L: Leaching CB	Inflow=0.00 cfs 43 cf Primary=0.00 cfs 43 cf
Link 2L: Isolated Wetlands	Inflow=0.02 cfs 346 cf Primary=0.02 cfs 346 cf
Link 3L: Spofford Pond Wetlands	Inflow=0.67 cfs 3,515 cf Primary=0.67 cfs 3,515 cf
Link 4L: Vernal Pool Wetlands	Inflow=25.12 cfs 84,998 cf Primary=25.12 cfs 84,998 cf

Total Runoff Area = 307,517 sf Runoff Volume = 88,901 cf Average Runoff Depth = 3.47"
32.65% Pervious = 100,409 sf 67.35% Impervious = 207,108 sf

Spofford Pre-Development

Prepared by Weston & Sampson

HydroCAD® 10.10-6a s/n 00455 © 2020 HydroCAD Software Solutions LLC

Type III 24-hr 25-year Rainfall=5.80"

Printed 11/2/2021

Page 39

Summary for Subcatchment 1S: Roof

Runoff = 9.28 cfs @ 12.08 hrs, Volume= 32,980 cf, Depth> 5.56"

Routed to Link 4L : Vernal Pool Wetlands

Runoff by SCS TR-20 method, UH=SCS, Weighted-CN, Time Span= 1.00-36.00 hrs, dt= 0.01 hrs
Type III 24-hr 25-year Rainfall=5.80"

Area (sf)	CN	Description
71,161	98	Roofs, HSG A
71,161		100.00% Impervious Area

Tc (min)	Length (feet)	Slope (ft/ft)	Velocity (ft/sec)	Capacity (cfs)	Description
6.0					Direct Entry,

Subcatchment 1S: Roof

Hydrograph

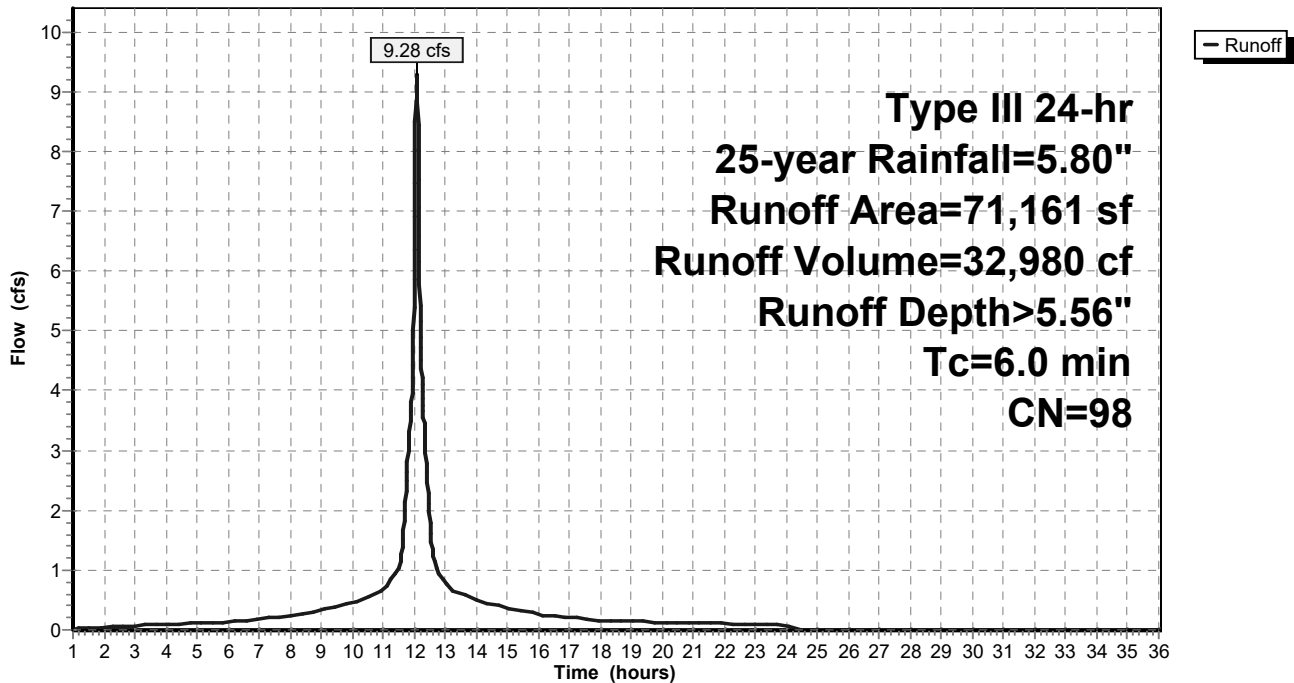

Spofford Pre-Development

Prepared by Weston & Sampson

HydroCAD® 10.10-6a s/n 00455 © 2020 HydroCAD Software Solutions LLC

Type III 24-hr 25-year Rainfall=5.80"

Printed 11/2/2021

Page 40

Summary for Subcatchment 2S: Sub 2

Runoff = 0.00 cfs @ 16.78 hrs, Volume= 43 cf, Depth= 0.05"

Routed to Link 1L : Leaching CB

Runoff by SCS TR-20 method, UH=SCS, Weighted-CN, Time Span= 1.00-36.00 hrs, dt= 0.01 hrs
Type III 24-hr 25-year Rainfall=5.80"

	Area (sf)	CN	Description
*	9,774	30	Grass
	9,774		100.00% Pervious Area

Tc (min)	Length (feet)	Slope (ft/ft)	Velocity (ft/sec)	Capacity (cfs)	Description
6.0					Direct Entry,

Subcatchment 2S: Sub 2

Hydrograph

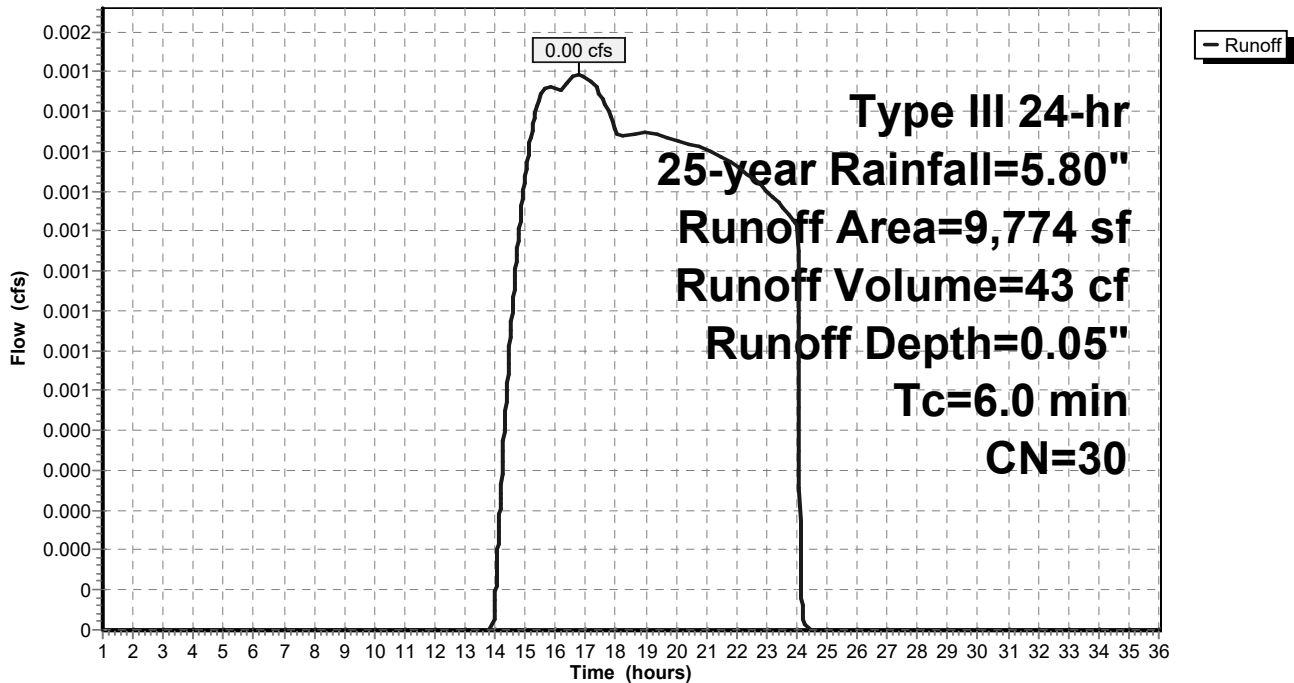

Spofford Pre-Development

Prepared by Weston & Sampson

HydroCAD® 10.10-6a s/n 00455 © 2020 HydroCAD Software Solutions LLC

Type III 24-hr 25-year Rainfall=5.80"

Printed 11/2/2021

Page 41

Summary for Subcatchment 3S: Sub 3

Runoff = 2.39 cfs @ 12.09 hrs, Volume= 7,422 cf, Depth= 3.60"
 Routed to Link 4L : Vernal Pool Wetlands

Runoff by SCS TR-20 method, UH=SCS, Weighted-CN, Time Span= 1.00-36.00 hrs, dt= 0.01 hrs
 Type III 24-hr 25-year Rainfall=5.80"

Area (sf)	CN	Description
8,972	98	Paved parking, HSG A
* 9,104	98	Turf (impervious)
* 5,760	30	Grass
894	30	Woods, Good, HSG A
24,730	80	Weighted Average
6,654		26.91% Pervious Area
18,076		73.09% Impervious Area

Tc (min)	Length (feet)	Slope (ft/ft)	Velocity (ft/sec)	Capacity (cfs)	Description
6.0					Direct Entry,

Subcatchment 3S: Sub 3

Hydrograph

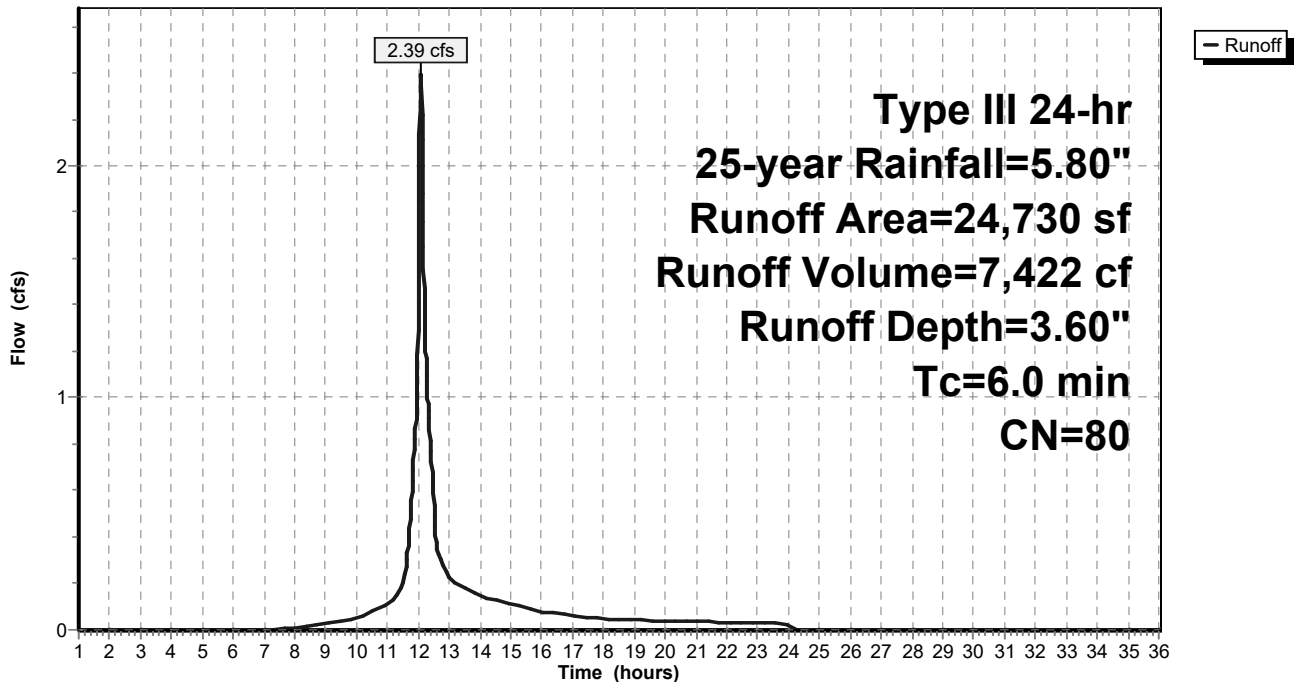

Spofford Pre-Development

Prepared by Weston & Sampson

HydroCAD® 10.10-6a s/n 00455 © 2020 HydroCAD Software Solutions LLC

Type III 24-hr 25-year Rainfall=5.80"

Printed 11/2/2021

Page 42

Summary for Subcatchment 4S: Sub 4

Runoff = 1.06 cfs @ 12.09 hrs, Volume= 3,278 cf, Depth= 2.92"

Routed to Link 4L : Vernal Pool Wetlands

Runoff by SCS TR-20 method, UH=SCS, Weighted-CN, Time Span= 1.00-36.00 hrs, dt= 0.01 hrs
 Type III 24-hr 25-year Rainfall=5.80"

Area (sf)	CN	Description
8,521	98	Paved parking, HSG A
2,064	30	Woods, Good, HSG A
* 2,871	30	Grass
13,456	73	Weighted Average
4,935		36.68% Pervious Area
8,521		63.32% Impervious Area

Tc (min)	Length (feet)	Slope (ft/ft)	Velocity (ft/sec)	Capacity (cfs)	Description
6.0					Direct Entry,

Subcatchment 4S: Sub 4

Hydrograph

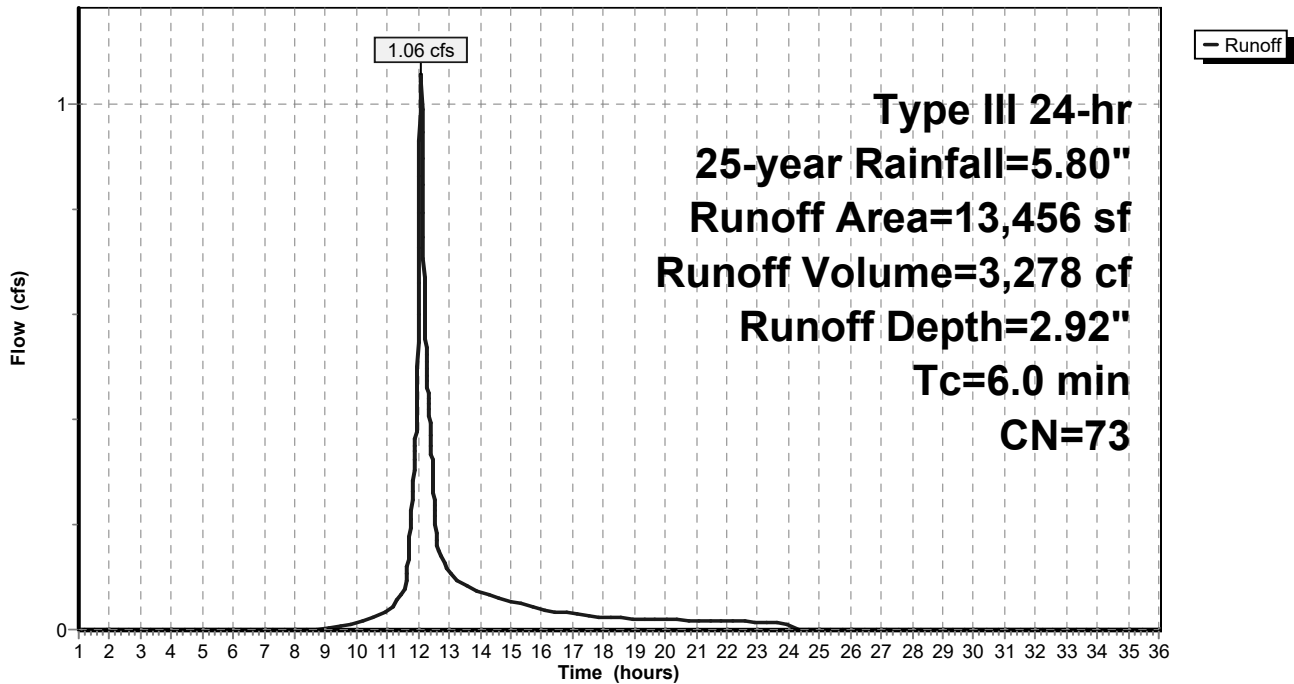

Spofford Pre-Development

Prepared by Weston & Sampson

HydroCAD® 10.10-6a s/n 00455 © 2020 HydroCAD Software Solutions LLC

Type III 24-hr 25-year Rainfall=5.80"

Printed 11/2/2021

Page 43

Summary for Subcatchment 5S: Sub 5

Runoff = 0.37 cfs @ 12.12 hrs, Volume= 1,885 cf, Depth= 0.78"

Routed to Link 3L : Spofford Pond Wetlands

Runoff by SCS TR-20 method, UH=SCS, Weighted-CN, Time Span= 1.00-36.00 hrs, dt= 0.01 hrs
Type III 24-hr 25-year Rainfall=5.80"

Area (sf)	CN	Description
6,737	98	Paved parking, HSG A
9,957	30	Woods, Good, HSG A
* 12,140	30	Grass
28,834	46	Weighted Average
22,097		76.64% Pervious Area
6,737		23.36% Impervious Area

Tc (min)	Length (feet)	Slope (ft/ft)	Velocity (ft/sec)	Capacity (cfs)	Description
6.0					Direct Entry,

Subcatchment 5S: Sub 5

Hydrograph

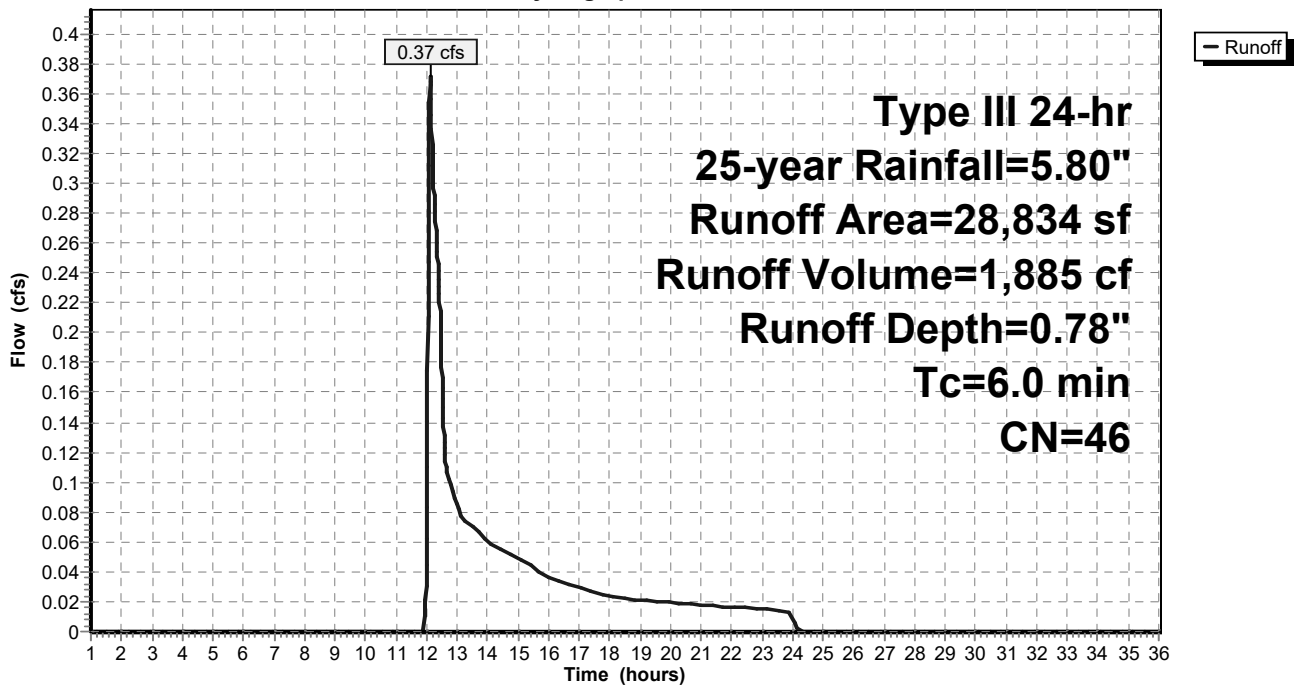

Spofford Pre-Development

Prepared by Weston & Sampson

HydroCAD® 10.10-6a s/n 00455 © 2020 HydroCAD Software Solutions LLC

Type III 24-hr 25-year Rainfall=5.80"

Printed 11/2/2021

Page 44

Summary for Subcatchment 6S: Sub 6

Runoff = 0.29 cfs @ 12.13 hrs, Volume= 1,630 cf, Depth= 0.72"

Routed to Link 3L : Spofford Pond Wetlands

Runoff by SCS TR-20 method, UH=SCS, Weighted-CN, Time Span= 1.00-36.00 hrs, dt= 0.01 hrs
 Type III 24-hr 25-year Rainfall=5.80"

Area (sf)	CN	Description
6,032	98	Paved parking, HSG A
* 21,032	30	Grass
27,064	45	Weighted Average
21,032		77.71% Pervious Area
6,032		22.29% Impervious Area

Tc (min)	Length (feet)	Slope (ft/ft)	Velocity (ft/sec)	Capacity (cfs)	Description
6.0					Direct Entry,

Subcatchment 6S: Sub 6

Hydrograph

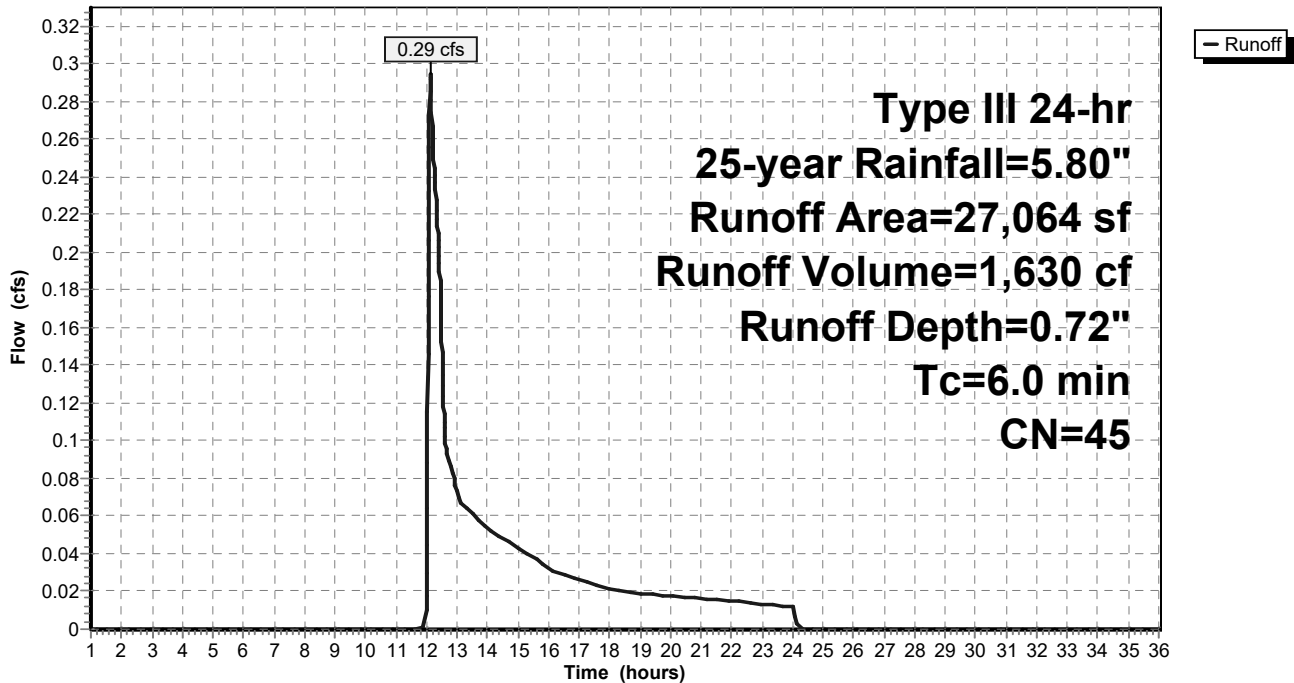

Spofford Pre-Development

Prepared by Weston & Sampson

HydroCAD® 10.10-6a s/n 00455 © 2020 HydroCAD Software Solutions LLC

Type III 24-hr 25-year Rainfall=5.80"

Printed 11/2/2021

Page 45

Summary for Subcatchment 7S: Sub 7

Runoff = 2.34 cfs @ 12.08 hrs, Volume= 8,053 cf, Depth= 5.33"

Routed to Link 4L : Vernal Pool Wetlands

Runoff by SCS TR-20 method, UH=SCS, Weighted-CN, Time Span= 1.00-36.00 hrs, dt= 0.01 hrs
 Type III 24-hr 25-year Rainfall=5.80"

Area (sf)	CN	Description
17,644	98	Paved parking, HSG A
* 492	30	Grass
18,136	96	Weighted Average
492		2.71% Pervious Area
17,644		97.29% Impervious Area

Tc (min)	Length (feet)	Slope (ft/ft)	Velocity (ft/sec)	Capacity (cfs)	Description
6.0					Direct Entry,

Subcatchment 7S: Sub 7

Hydrograph

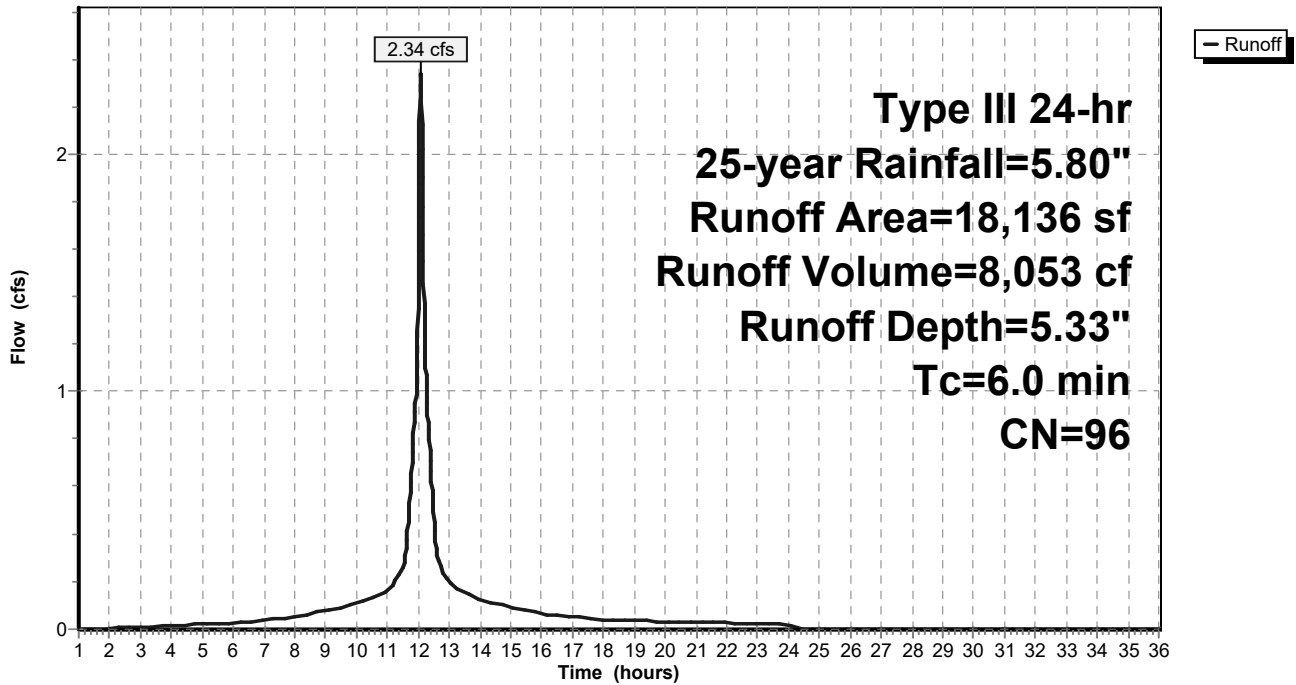

Summary for Subcatchment 8S: Sub 8

Runoff = 0.02 cfs @ 12.46 hrs, Volume= 346 cf, Depth= 0.25"
 Routed to Link 2L : Isolated Wetlands

Runoff by SCS TR-20 method, UH=SCS, Weighted-CN, Time Span= 1.00-36.00 hrs, dt= 0.01 hrs
 Type III 24-hr 25-year Rainfall=5.80"

Area (sf)	CN	Description
1,488	98	Paved parking, HSG A
* 15,009	30	Grass
16,497	36	Weighted Average
15,009		90.98% Pervious Area
1,488		9.02% Impervious Area

Tc (min)	Length (feet)	Slope (ft/ft)	Velocity (ft/sec)	Capacity (cfs)	Description
6.0					Direct Entry,

Subcatchment 8S: Sub 8

Hydrograph

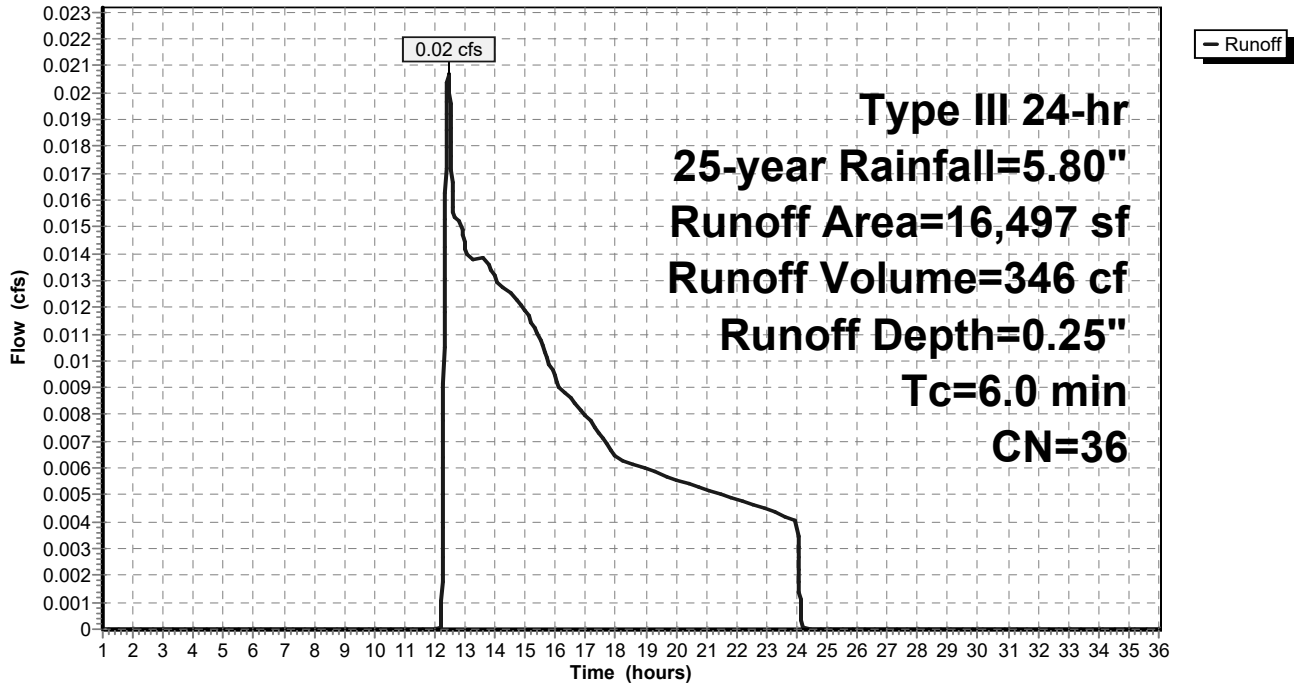

Spofford Pre-Development

Prepared by Weston & Sampson

HydroCAD® 10.10-6a s/n 00455 © 2020 HydroCAD Software Solutions LLC

Type III 24-hr 25-year Rainfall=5.80"

Printed 11/2/2021

Page 47

Summary for Subcatchment 9S: Sub 9

Runoff = 5.27 cfs @ 12.08 hrs, Volume= 18,422 cf, Depth= 5.44"
 Routed to Link 4L : Vernal Pool Wetlands

Runoff by SCS TR-20 method, UH=SCS, Weighted-CN, Time Span= 1.00-36.00 hrs, dt= 0.01 hrs
 Type III 24-hr 25-year Rainfall=5.80"

Area (sf)	CN	Description
39,871	98	Paved parking, HSG A
* 731	30	Grass
40,602	97	Weighted Average
731		1.80% Pervious Area
39,871		98.20% Impervious Area

Tc (min)	Length (feet)	Slope (ft/ft)	Velocity (ft/sec)	Capacity (cfs)	Description
6.0					Direct Entry,

Subcatchment 9S: Sub 9

Hydrograph

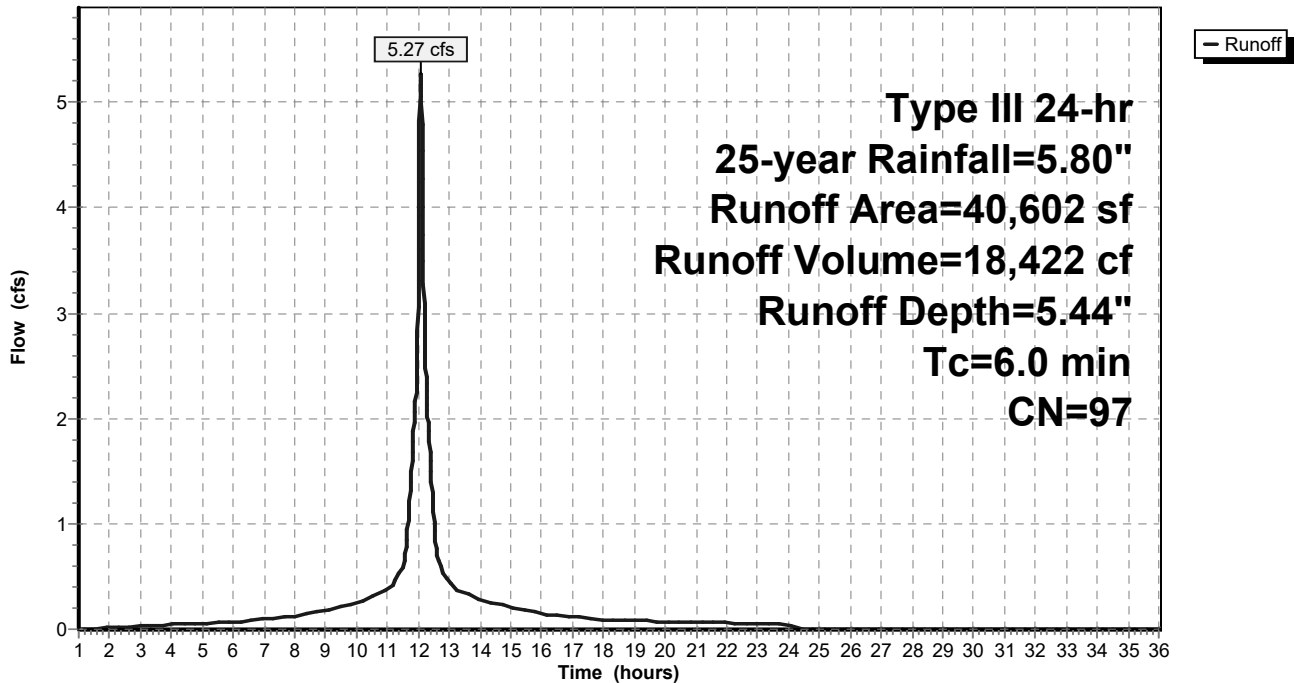

Spofford Pre-Development

Prepared by Weston & Sampson

HydroCAD® 10.10-6a s/n 00455 © 2020 HydroCAD Software Solutions LLC

Type III 24-hr 25-year Rainfall=5.80"

Printed 11/2/2021

Page 48

Summary for Subcatchment 10S: Sub 10

Runoff = 1.65 cfs @ 12.09 hrs, Volume= 5,104 cf, Depth= 3.31"

Routed to Link 4L : Vernal Pool Wetlands

Runoff by SCS TR-20 method, UH=SCS, Weighted-CN, Time Span= 1.00-36.00 hrs, dt= 0.01 hrs
Type III 24-hr 25-year Rainfall=5.80"

Area (sf)	CN	Description
12,797	98	Paved parking, HSG A
424	30	Woods, Good, HSG A
* 5,312	30	Grass
18,533	77	Weighted Average
5,736		30.95% Pervious Area
12,797		69.05% Impervious Area

Tc (min)	Length (feet)	Slope (ft/ft)	Velocity (ft/sec)	Capacity (cfs)	Description
6.0					Direct Entry,

Subcatchment 10S: Sub 10

Hydrograph

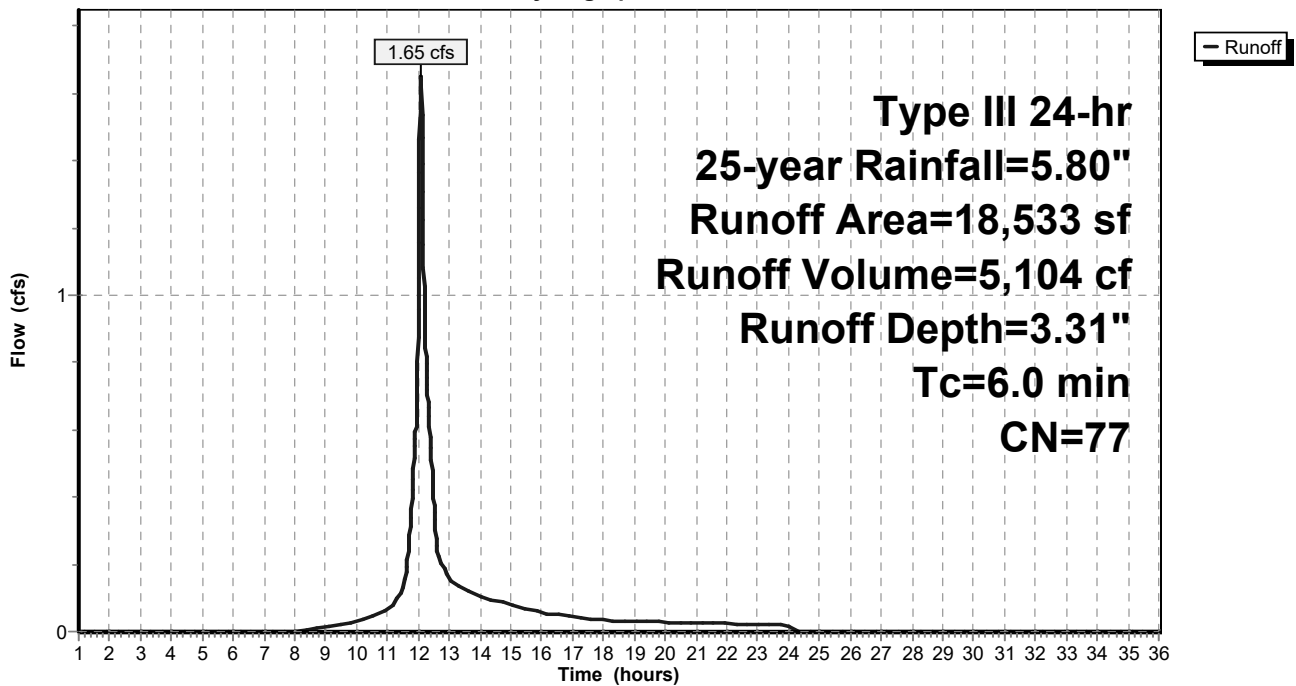

Spofford Pre-Development

Prepared by Weston & Sampson

HydroCAD® 10.10-6a s/n 00455 © 2020 HydroCAD Software Solutions LLC

Type III 24-hr 25-year Rainfall=5.80"

Printed 11/2/2021

Page 49

Summary for Subcatchment 11S: Sub 11

Runoff = 3.15 cfs @ 12.09 hrs, Volume= 9,739 cf, Depth= 3.02"
 Routed to Link 4L : Vernal Pool Wetlands

Runoff by SCS TR-20 method, UH=SCS, Weighted-CN, Time Span= 1.00-36.00 hrs, dt= 0.01 hrs
 Type III 24-hr 25-year Rainfall=5.80"

Area (sf)	CN	Description
5,533	98	Paved parking, HSG A
4,499	30	Woods, Good, HSG A
* 9,450	30	Grass
* 19,248	98	Compacted Gravel
38,730	74	Weighted Average
13,949		36.02% Pervious Area
24,781		63.98% Impervious Area

Tc (min)	Length (feet)	Slope (ft/ft)	Velocity (ft/sec)	Capacity (cfs)	Description
6.0					Direct Entry,

Subcatchment 11S: Sub 11

Hydrograph

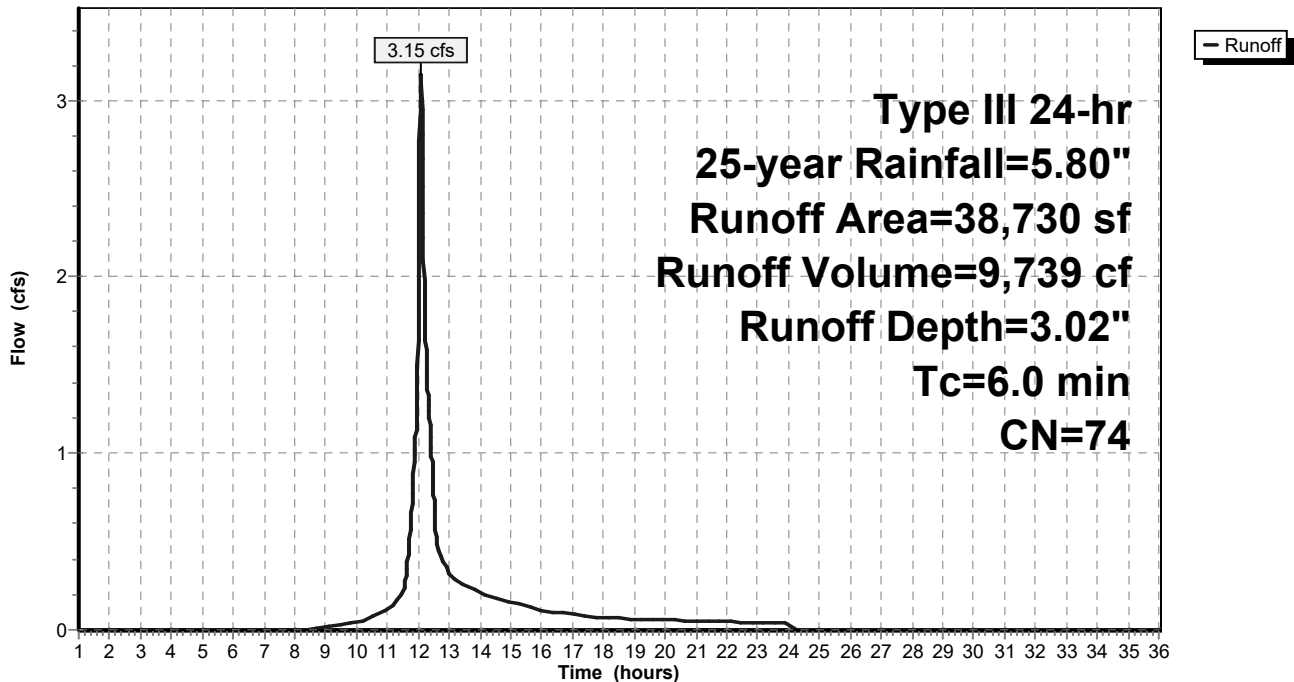

Summary for Link 1L: Leaching CB

Inflow Area = 9,774 sf, 0.00% Impervious, Inflow Depth = 0.05" for 25-year event
Inflow = 0.00 cfs @ 16.78 hrs, Volume= 43 cf
Primary = 0.00 cfs @ 16.78 hrs, Volume= 43 cf, Atten= 0%, Lag= 0.0 min

Primary outflow = Inflow, Time Span= 1.00-36.00 hrs, dt= 0.01 hrs

Link 1L: Leaching CB

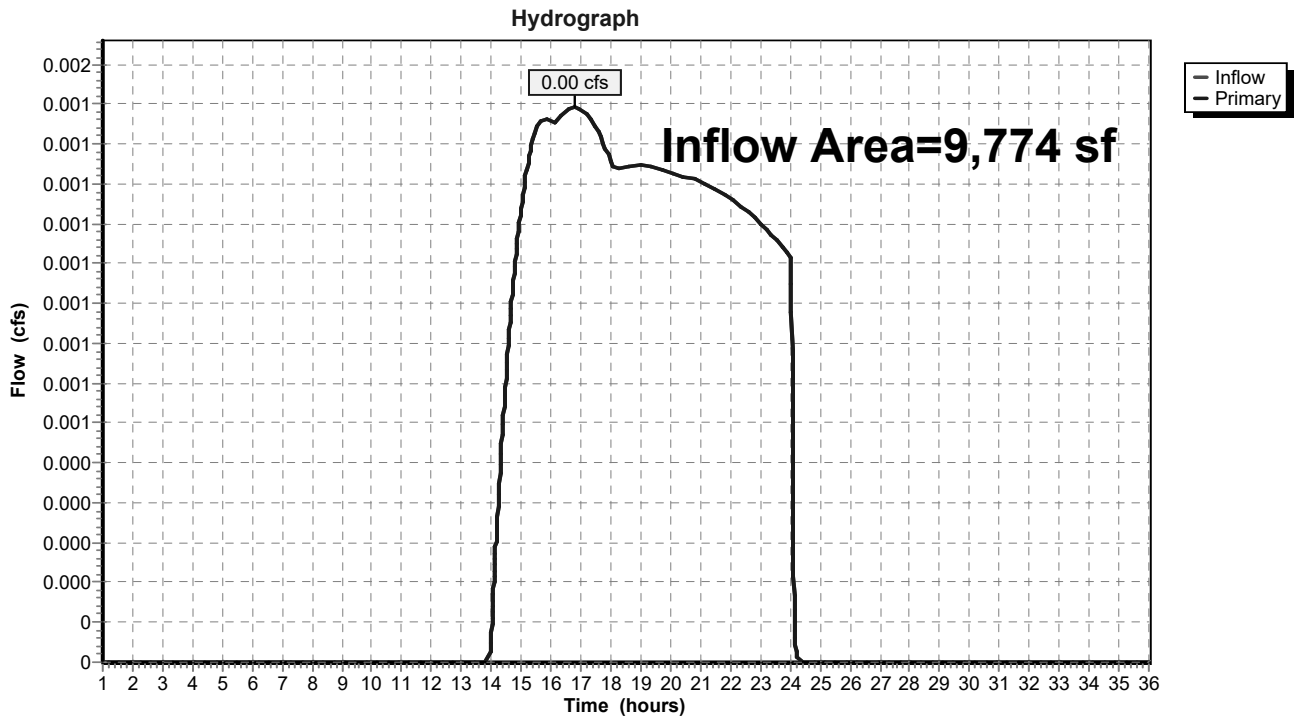

Summary for Link 2L: Isolated Wetlands

Inflow Area = 16,497 sf, 9.02% Impervious, Inflow Depth = 0.25" for 25-year event
Inflow = 0.02 cfs @ 12.46 hrs, Volume= 346 cf
Primary = 0.02 cfs @ 12.46 hrs, Volume= 346 cf, Atten= 0%, Lag= 0.0 min

Primary outflow = Inflow, Time Span= 1.00-36.00 hrs, dt= 0.01 hrs

Link 2L: Isolated Wetlands

Hydrograph

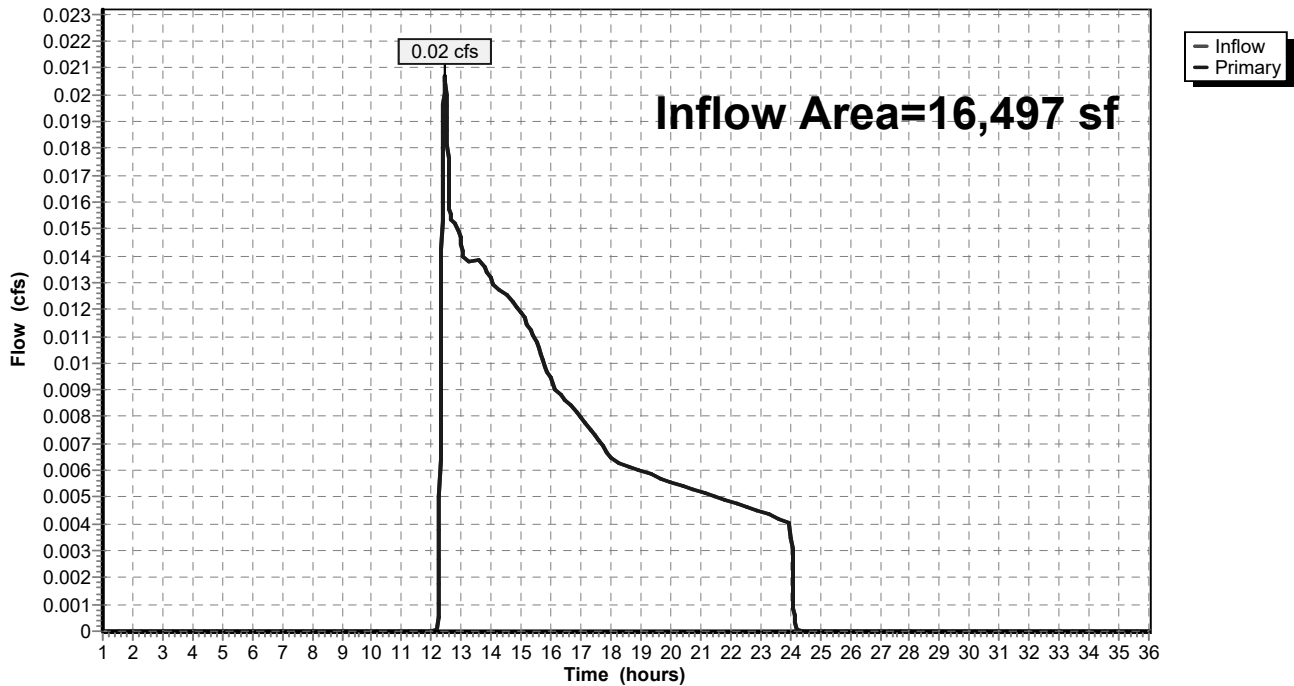

Spofford Pre-Development

Prepared by Weston & Sampson

HydroCAD® 10.10-6a s/n 00455 © 2020 HydroCAD Software Solutions LLC

Type III 24-hr 25-year Rainfall=5.80"

Printed 11/2/2021

Page 52

Summary for Link 3L: Spofford Pond Wetlands

Inflow Area = 55,898 sf, 22.84% Impervious, Inflow Depth = 0.75" for 25-year event
Inflow = 0.67 cfs @ 12.13 hrs, Volume= 3,515 cf
Primary = 0.67 cfs @ 12.13 hrs, Volume= 3,515 cf, Atten= 0%, Lag= 0.0 min

Primary outflow = Inflow, Time Span= 1.00-36.00 hrs, dt= 0.01 hrs

Link 3L: Spofford Pond Wetlands

Hydrograph

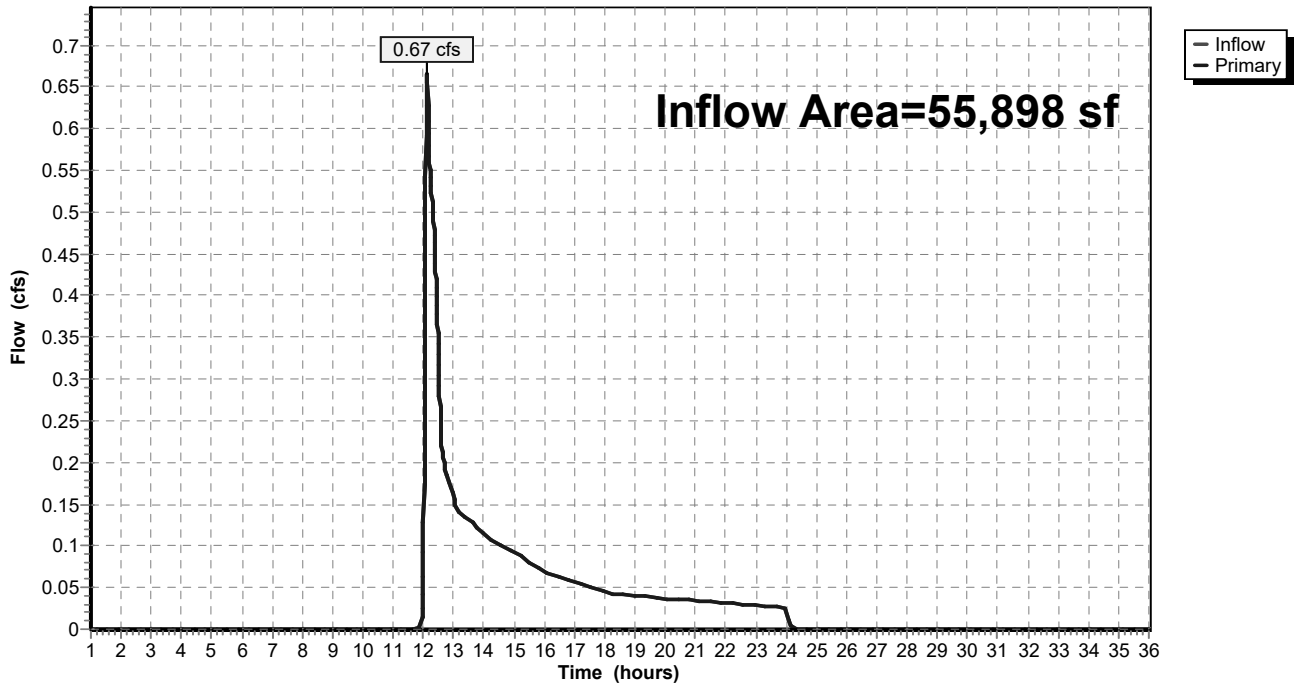

Summary for Link 4L: Vernal Pool Wetlands

Inflow Area = 225,348 sf, 85.58% Impervious, Inflow Depth > 4.53" for 25-year event
Inflow = 25.12 cfs @ 12.09 hrs, Volume= 84,998 cf
Primary = 25.12 cfs @ 12.09 hrs, Volume= 84,998 cf, Atten= 0%, Lag= 0.0 min
Routed to nonexistent node 25L

Primary outflow = Inflow, Time Span= 1.00-36.00 hrs, dt= 0.01 hrs

Link 4L: Vernal Pool Wetlands

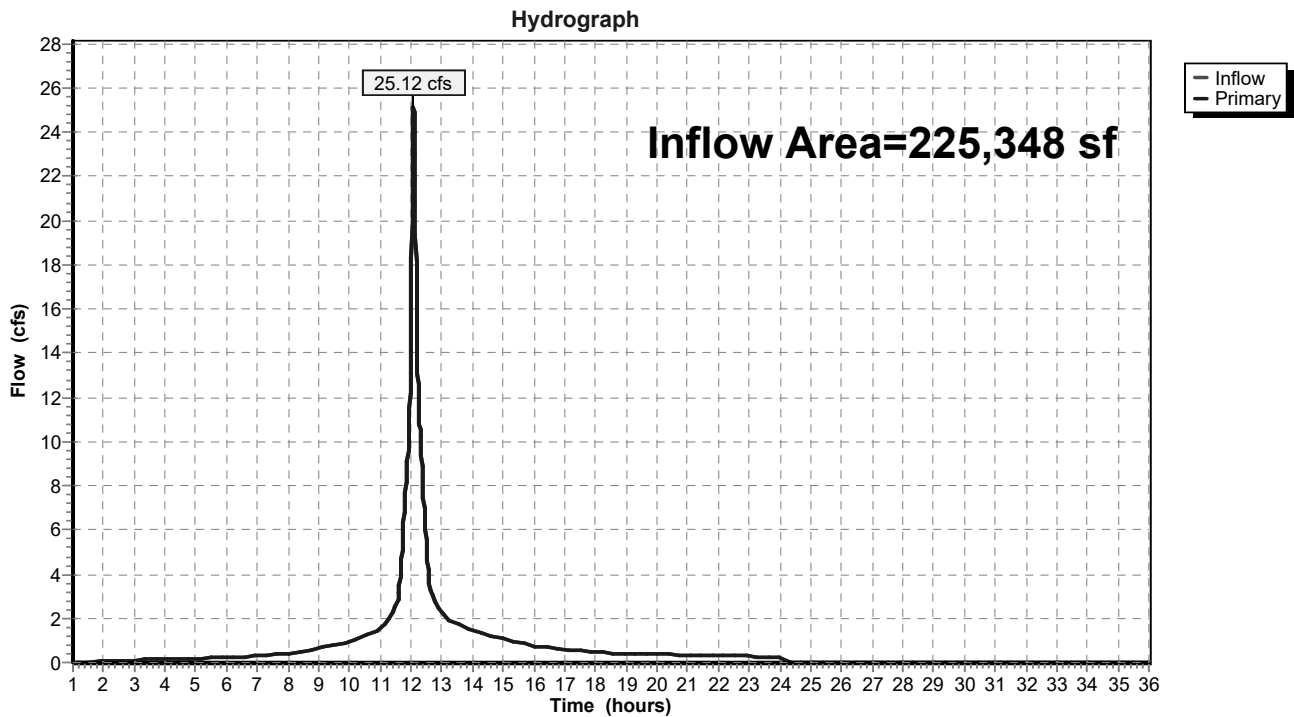

Time span=1.00-36.00 hrs, dt=0.01 hrs, 3501 points
 Runoff by SCS TR-20 method, UH=SCS, Weighted-CN
 Reach routing by Dyn-Stor-Ind method - Pond routing by Dyn-Stor-Ind method

Subcatchment1S: Roof	Runoff Area=71,161 sf 100.00% Impervious Runoff Depth>6.86" Tc=6.0 min CN=98 Runoff=11.38 cfs 40,671 cf
Subcatchment2S: Sub 2	Runoff Area=9,774 sf 0.00% Impervious Runoff Depth=0.23" Tc=6.0 min CN=30 Runoff=0.01 cfs 187 cf
Subcatchment3S: Sub 3	Runoff Area=24,730 sf 73.09% Impervious Runoff Depth=4.79" Tc=6.0 min CN=80 Runoff=3.15 cfs 9,865 cf
Subcatchment4S: Sub 4	Runoff Area=13,456 sf 63.32% Impervious Runoff Depth=4.02" Tc=6.0 min CN=73 Runoff=1.46 cfs 4,510 cf
Subcatchment5S: Sub 5	Runoff Area=28,834 sf 23.36% Impervious Runoff Depth=1.37" Tc=6.0 min CN=46 Runoff=0.84 cfs 3,290 cf
Subcatchment6S: Sub 6	Runoff Area=27,064 sf 22.29% Impervious Runoff Depth=1.28" Tc=6.0 min CN=45 Runoff=0.72 cfs 2,896 cf
Subcatchment7S: Sub 7	Runoff Area=18,136 sf 97.29% Impervious Runoff Depth=6.62" Tc=6.0 min CN=96 Runoff=2.88 cfs 10,010 cf
Subcatchment8S: Sub 8	Runoff Area=16,497 sf 9.02% Impervious Runoff Depth=0.59" Tc=6.0 min CN=36 Runoff=0.10 cfs 810 cf
Subcatchment9S: Sub 9	Runoff Area=40,602 sf 98.20% Impervious Runoff Depth>6.74" Tc=6.0 min CN=97 Runoff=6.47 cfs 22,811 cf
Subcatchment10S: Sub 10	Runoff Area=18,533 sf 69.05% Impervious Runoff Depth=4.46" Tc=6.0 min CN=77 Runoff=2.21 cfs 6,882 cf
Subcatchment11S: Sub 11	Runoff Area=38,730 sf 63.98% Impervious Runoff Depth=4.13" Tc=6.0 min CN=74 Runoff=4.30 cfs 13,328 cf
Link 1L: Leaching CB	Inflow=0.01 cfs 187 cf Primary=0.01 cfs 187 cf
Link 2L: Isolated Wetlands	Inflow=0.10 cfs 810 cf Primary=0.10 cfs 810 cf
Link 3L: Spofford Pond Wetlands	Inflow=1.56 cfs 6,187 cf Primary=1.56 cfs 6,187 cf
Link 4L: Vernal Pool Wetlands	Inflow=31.84 cfs 108,076 cf Primary=31.84 cfs 108,076 cf

Total Runoff Area = 307,517 sf Runoff Volume = 115,260 cf Average Runoff Depth = 4.50"
32.65% Pervious = 100,409 sf 67.35% Impervious = 207,108 sf

Spofford Pre-Development

Prepared by Weston & Sampson

HydroCAD® 10.10-6a s/n 00455 © 2020 HydroCAD Software Solutions LLC

Type III 24-hr 50-year Rainfall=7.10"

Printed 11/2/2021

Page 55

Summary for Subcatchment 1S: Roof

Runoff = 11.38 cfs @ 12.08 hrs, Volume= 40,671 cf, Depth> 6.86"

Routed to Link 4L : Vernal Pool Wetlands

Runoff by SCS TR-20 method, UH=SCS, Weighted-CN, Time Span= 1.00-36.00 hrs, dt= 0.01 hrs
Type III 24-hr 50-year Rainfall=7.10"

Area (sf)	CN	Description
71,161	98	Roofs, HSG A
71,161		100.00% Impervious Area

Tc (min)	Length (feet)	Slope (ft/ft)	Velocity (ft/sec)	Capacity (cfs)	Description
6.0					Direct Entry,

Subcatchment 1S: Roof

Hydrograph

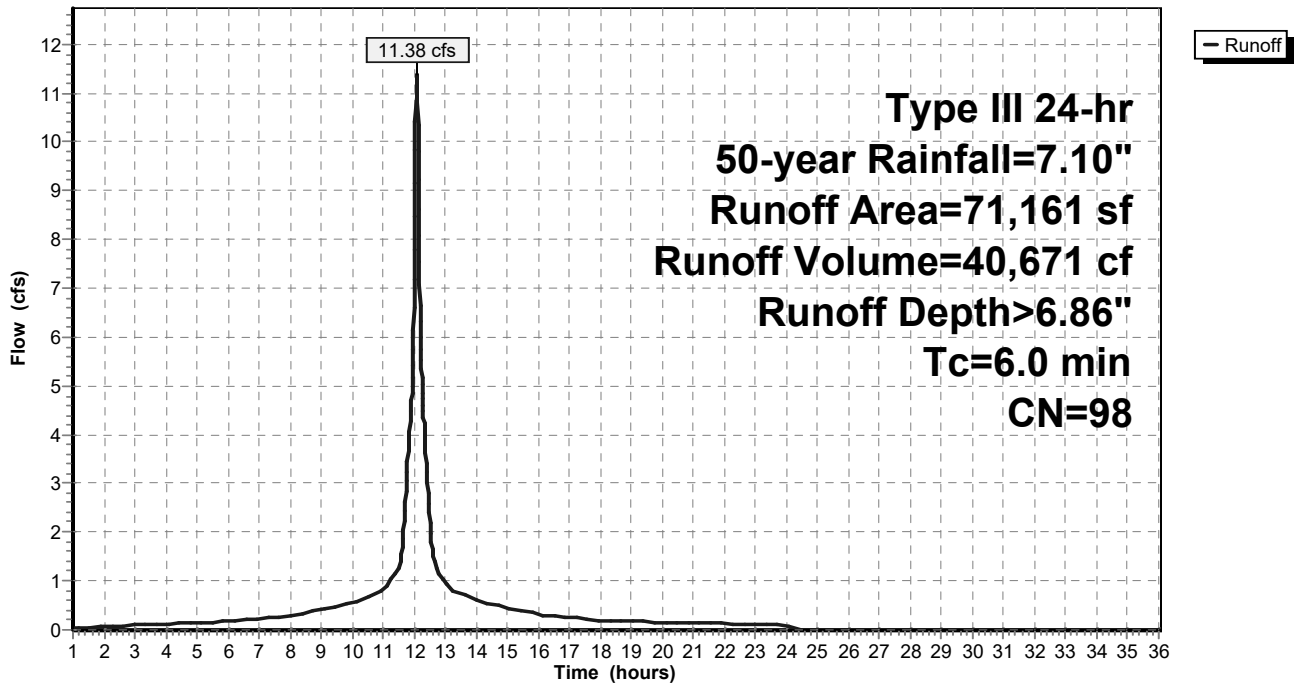

Summary for Subcatchment 2S: Sub 2

Runoff = 0.01 cfs @ 13.70 hrs, Volume= 187 cf, Depth= 0.23"
 Routed to Link 1L : Leaching CB

Runoff by SCS TR-20 method, UH=SCS, Weighted-CN, Time Span= 1.00-36.00 hrs, dt= 0.01 hrs
 Type III 24-hr 50-year Rainfall=7.10"

Area (sf)	CN	Description
* 9,774	30	Grass
9,774		100.00% Pervious Area

Tc (min)	Length (feet)	Slope (ft/ft)	Velocity (ft/sec)	Capacity (cfs)	Description
6.0					Direct Entry,

Subcatchment 2S: Sub 2

Hydrograph

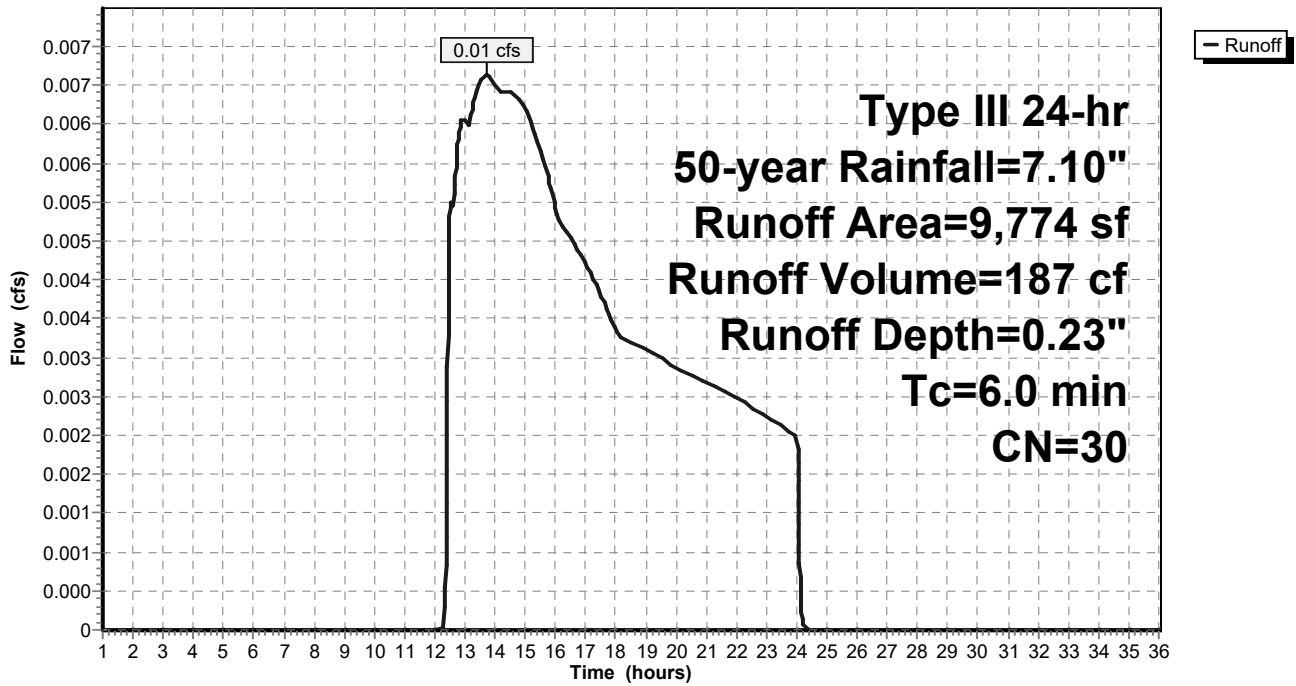

Spofford Pre-Development

Prepared by Weston & Sampson

HydroCAD® 10.10-6a s/n 00455 © 2020 HydroCAD Software Solutions LLC

Type III 24-hr 50-year Rainfall=7.10"

Printed 11/2/2021

Page 57

Summary for Subcatchment 3S: Sub 3

Runoff = 3.15 cfs @ 12.09 hrs, Volume= 9,865 cf, Depth= 4.79"
 Routed to Link 4L : Vernal Pool Wetlands

Runoff by SCS TR-20 method, UH=SCS, Weighted-CN, Time Span= 1.00-36.00 hrs, dt= 0.01 hrs
 Type III 24-hr 50-year Rainfall=7.10"

	Area (sf)	CN	Description
	8,972	98	Paved parking, HSG A
*	9,104	98	Turf (impervious)
*	5,760	30	Grass
	894	30	Woods, Good, HSG A
	24,730	80	Weighted Average
	6,654		26.91% Pervious Area
	18,076		73.09% Impervious Area

Tc (min)	Length (feet)	Slope (ft/ft)	Velocity (ft/sec)	Capacity (cfs)	Description
6.0					Direct Entry,

Subcatchment 3S: Sub 3

Hydrograph

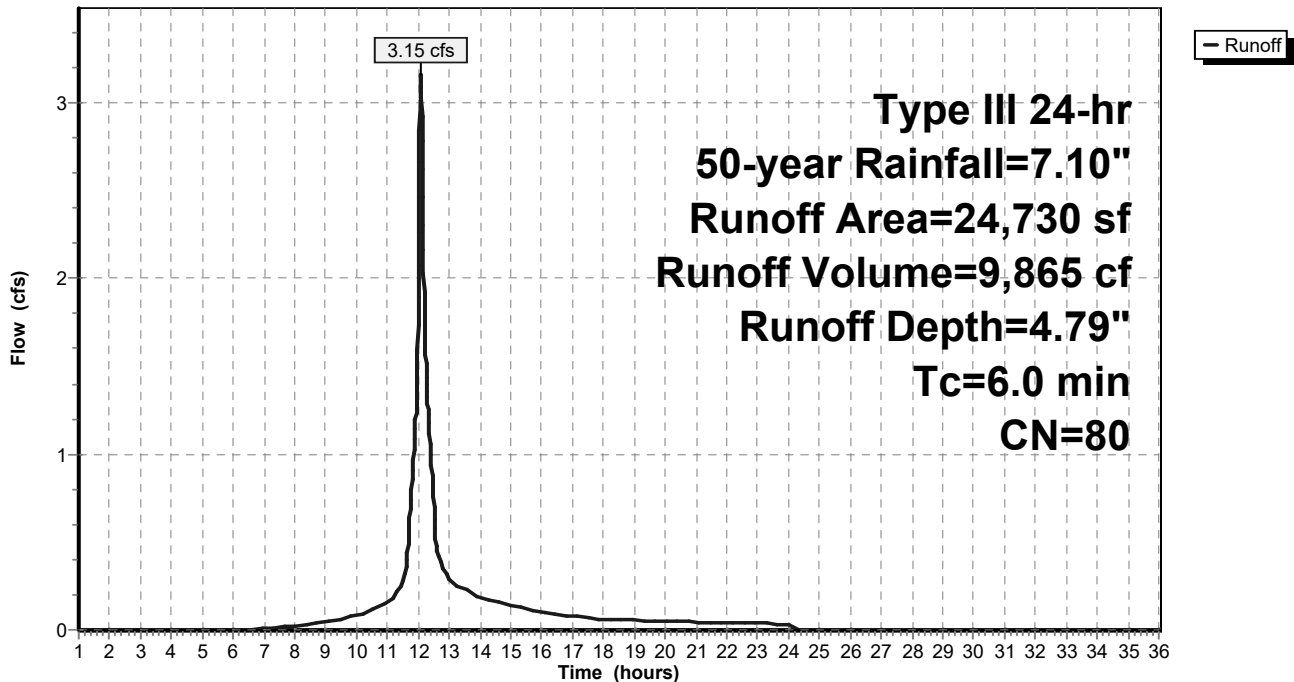

Spofford Pre-Development

Prepared by Weston & Sampson

HydroCAD® 10.10-6a s/n 00455 © 2020 HydroCAD Software Solutions LLC

Type III 24-hr 50-year Rainfall=7.10"

Printed 11/2/2021

Page 58

Summary for Subcatchment 4S: Sub 4

Runoff = 1.46 cfs @ 12.09 hrs, Volume= 4,510 cf, Depth= 4.02"

Routed to Link 4L : Vernal Pool Wetlands

Runoff by SCS TR-20 method, UH=SCS, Weighted-CN, Time Span= 1.00-36.00 hrs, dt= 0.01 hrs
Type III 24-hr 50-year Rainfall=7.10"

Area (sf)	CN	Description
8,521	98	Paved parking, HSG A
2,064	30	Woods, Good, HSG A
* 2,871	30	Grass
13,456	73	Weighted Average
4,935		36.68% Pervious Area
8,521		63.32% Impervious Area

Tc (min)	Length (feet)	Slope (ft/ft)	Velocity (ft/sec)	Capacity (cfs)	Description
6.0					Direct Entry,

Subcatchment 4S: Sub 4

Hydrograph

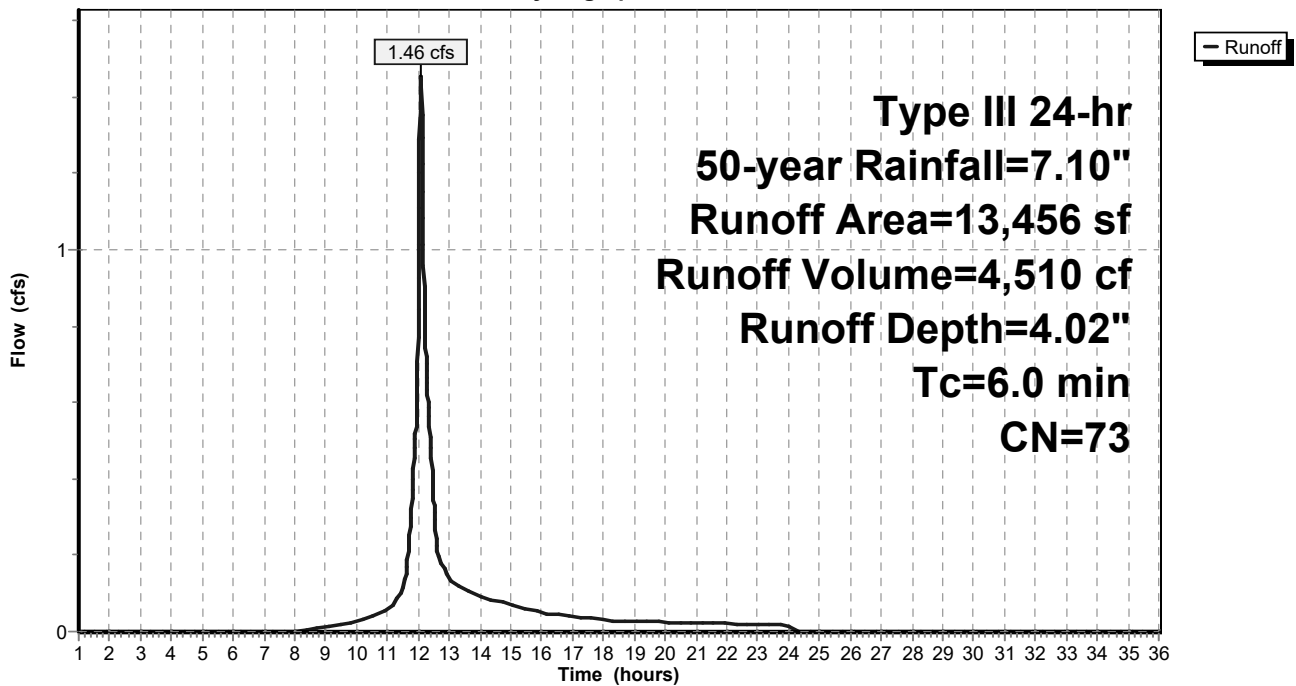

Spofford Pre-Development

Prepared by Weston & Sampson

HydroCAD® 10.10-6a s/n 00455 © 2020 HydroCAD Software Solutions LLC

Type III 24-hr 50-year Rainfall=7.10"

Printed 11/2/2021

Page 59

Summary for Subcatchment 5S: Sub 5

Runoff = 0.84 cfs @ 12.11 hrs, Volume= 3,290 cf, Depth= 1.37"

Routed to Link 3L : Spofford Pond Wetlands

Runoff by SCS TR-20 method, UH=SCS, Weighted-CN, Time Span= 1.00-36.00 hrs, dt= 0.01 hrs
Type III 24-hr 50-year Rainfall=7.10"

Area (sf)	CN	Description
6,737	98	Paved parking, HSG A
9,957	30	Woods, Good, HSG A
* 12,140	30	Grass
28,834	46	Weighted Average
22,097		76.64% Pervious Area
6,737		23.36% Impervious Area

Tc (min)	Length (feet)	Slope (ft/ft)	Velocity (ft/sec)	Capacity (cfs)	Description
6.0					Direct Entry,

Subcatchment 5S: Sub 5

Hydrograph

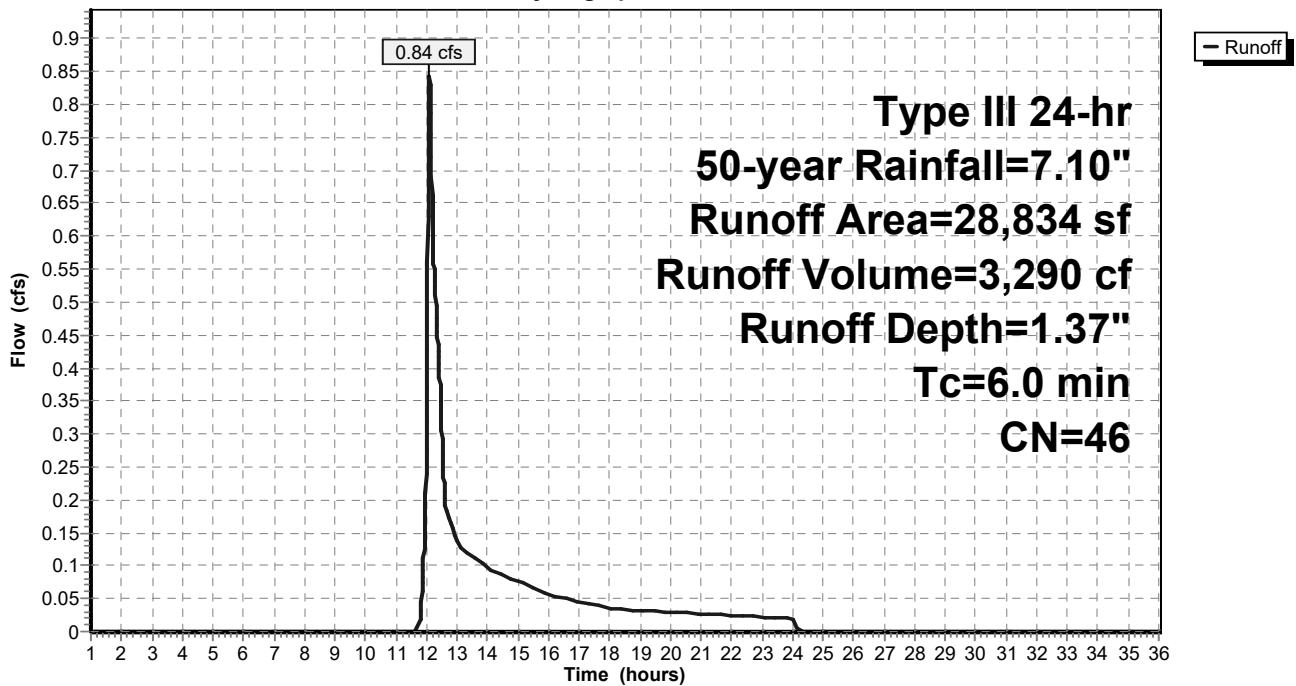

Spofford Pre-Development

Prepared by Weston & Sampson

HydroCAD® 10.10-6a s/n 00455 © 2020 HydroCAD Software Solutions LLC

Type III 24-hr 50-year Rainfall=7.10"

Printed 11/2/2021

Page 60

Summary for Subcatchment 6S: Sub 6

Runoff = 0.72 cfs @ 12.11 hrs, Volume= 2,896 cf, Depth= 1.28"

Routed to Link 3L : Spofford Pond Wetlands

Runoff by SCS TR-20 method, UH=SCS, Weighted-CN, Time Span= 1.00-36.00 hrs, dt= 0.01 hrs
 Type III 24-hr 50-year Rainfall=7.10"

Area (sf)	CN	Description
6,032	98	Paved parking, HSG A
* 21,032	30	Grass
27,064	45	Weighted Average
21,032		77.71% Pervious Area
6,032		22.29% Impervious Area

Tc (min)	Length (feet)	Slope (ft/ft)	Velocity (ft/sec)	Capacity (cfs)	Description
6.0					Direct Entry,

Subcatchment 6S: Sub 6

Hydrograph

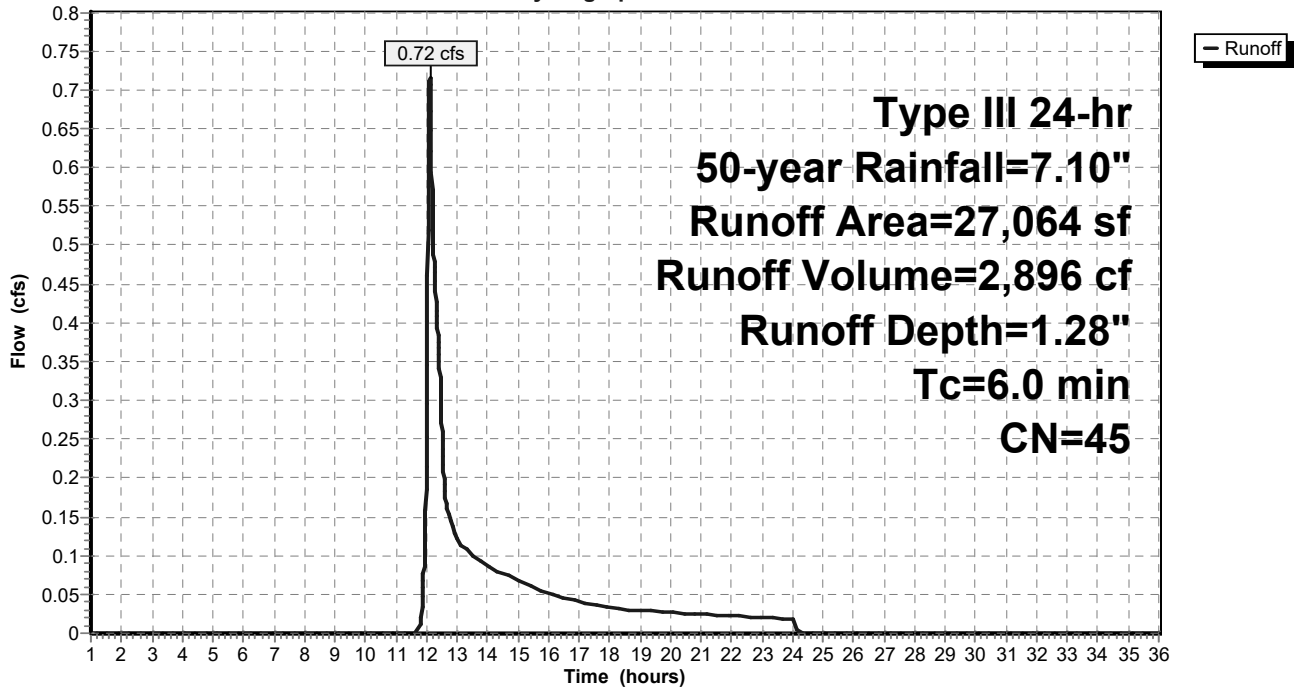

Spofford Pre-Development

Prepared by Weston & Sampson

HydroCAD® 10.10-6a s/n 00455 © 2020 HydroCAD Software Solutions LLC

Type III 24-hr 50-year Rainfall=7.10"

Printed 11/2/2021

Page 61

Summary for Subcatchment 7S: Sub 7

Runoff = 2.88 cfs @ 12.08 hrs, Volume= 10,010 cf, Depth= 6.62"

Routed to Link 4L : Vernal Pool Wetlands

Runoff by SCS TR-20 method, UH=SCS, Weighted-CN, Time Span= 1.00-36.00 hrs, dt= 0.01 hrs
 Type III 24-hr 50-year Rainfall=7.10"

Area (sf)	CN	Description
17,644	98	Paved parking, HSG A
* 492	30	Grass
18,136	96	Weighted Average
492		2.71% Pervious Area
17,644		97.29% Impervious Area

Tc (min)	Length (feet)	Slope (ft/ft)	Velocity (ft/sec)	Capacity (cfs)	Description
6.0					Direct Entry,

Subcatchment 7S: Sub 7

Hydrograph

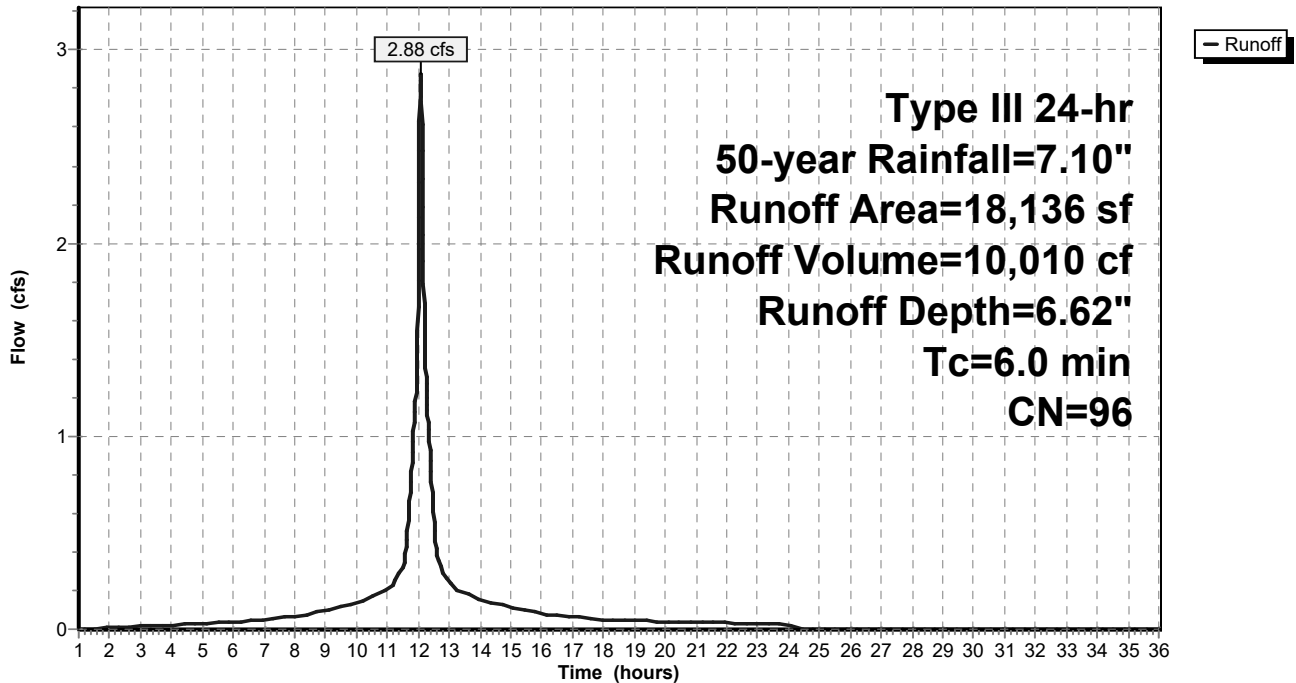

Summary for Subcatchment 8S: Sub 8

Runoff = 0.10 cfs @ 12.32 hrs, Volume= 810 cf, Depth= 0.59"
 Routed to Link 2L : Isolated Wetlands

Runoff by SCS TR-20 method, UH=SCS, Weighted-CN, Time Span= 1.00-36.00 hrs, dt= 0.01 hrs
 Type III 24-hr 50-year Rainfall=7.10"

Area (sf)	CN	Description
1,488	98	Paved parking, HSG A
* 15,009	30	Grass
16,497	36	Weighted Average
15,009		90.98% Pervious Area
1,488		9.02% Impervious Area

Tc (min)	Length (feet)	Slope (ft/ft)	Velocity (ft/sec)	Capacity (cfs)	Description
6.0					Direct Entry,

Subcatchment 8S: Sub 8

Hydrograph

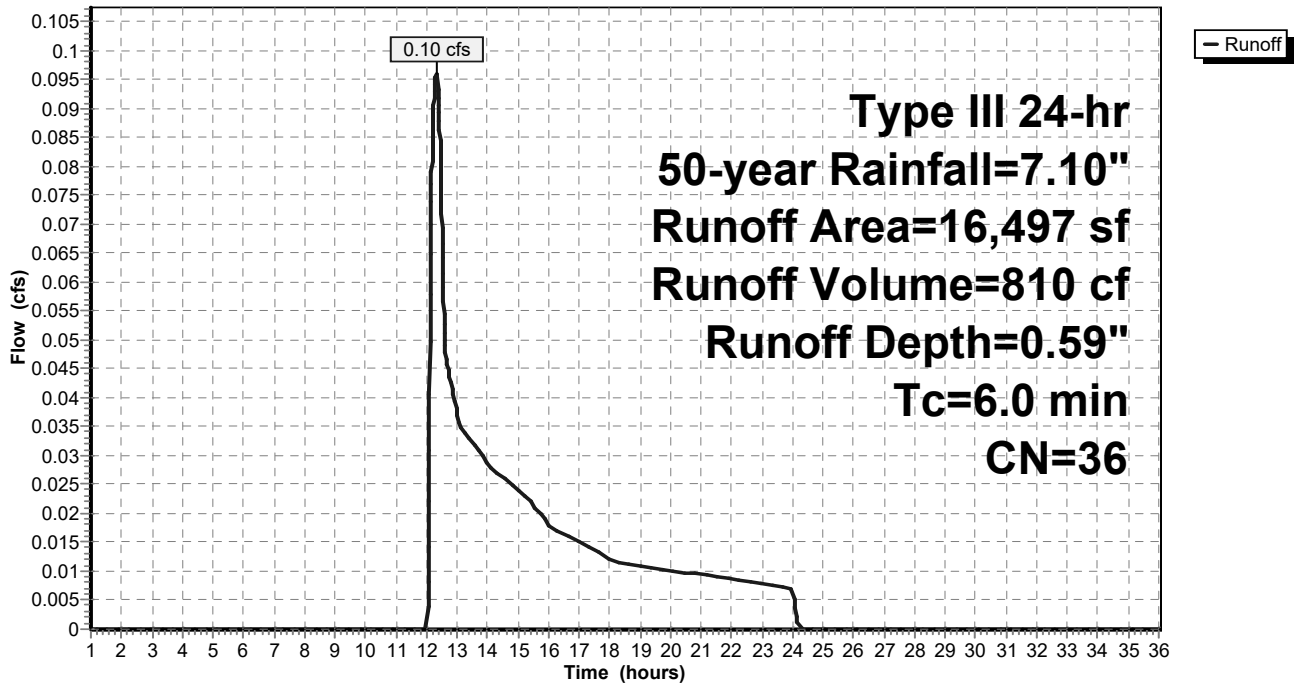

Spofford Pre-Development

Prepared by Weston & Sampson

HydroCAD® 10.10-6a s/n 00455 © 2020 HydroCAD Software Solutions LLC

Type III 24-hr 50-year Rainfall=7.10"

Printed 11/2/2021

Page 63

Summary for Subcatchment 9S: Sub 9

Runoff = 6.47 cfs @ 12.08 hrs, Volume= 22,811 cf, Depth> 6.74"
 Routed to Link 4L : Vernal Pool Wetlands

Runoff by SCS TR-20 method, UH=SCS, Weighted-CN, Time Span= 1.00-36.00 hrs, dt= 0.01 hrs
 Type III 24-hr 50-year Rainfall=7.10"

Area (sf)	CN	Description
39,871	98	Paved parking, HSG A
* 731	30	Grass
40,602	97	Weighted Average
731		1.80% Pervious Area
39,871		98.20% Impervious Area

Tc (min)	Length (feet)	Slope (ft/ft)	Velocity (ft/sec)	Capacity (cfs)	Description
6.0					Direct Entry,

Subcatchment 9S: Sub 9

Hydrograph

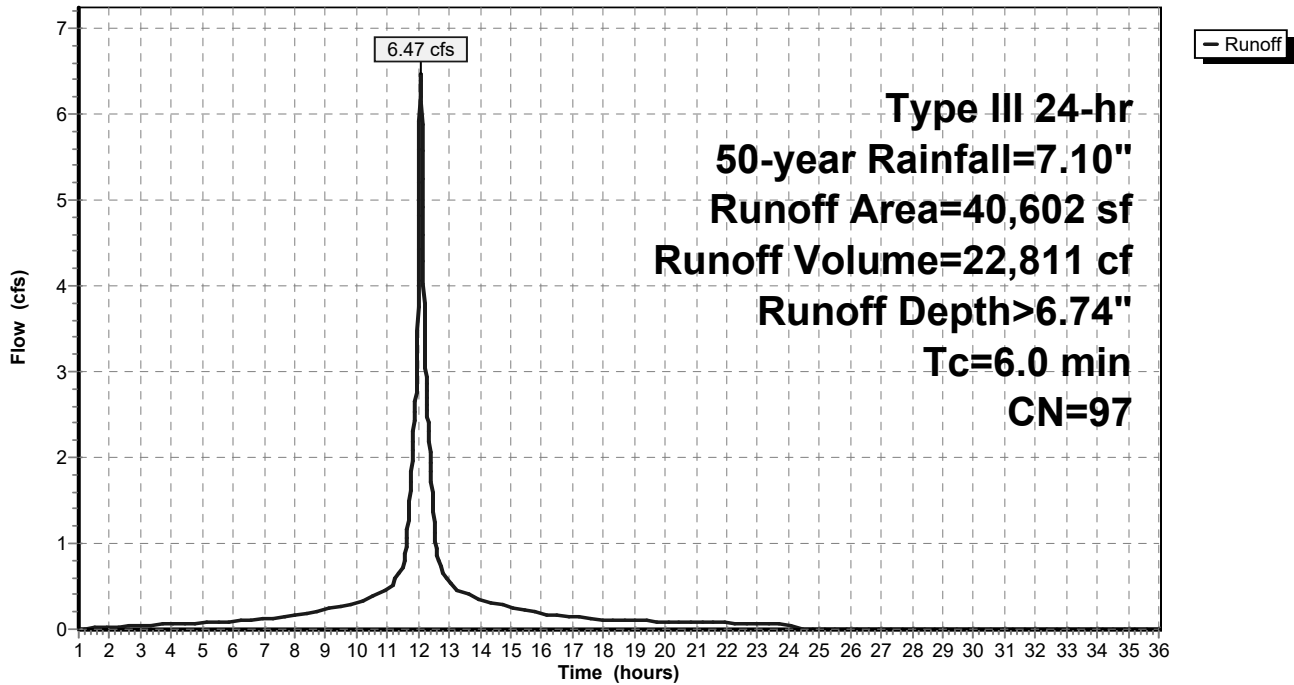

Spofford Pre-Development

Prepared by Weston & Sampson

HydroCAD® 10.10-6a s/n 00455 © 2020 HydroCAD Software Solutions LLC

Type III 24-hr 50-year Rainfall=7.10"

Printed 11/2/2021

Page 64

Summary for Subcatchment 10S: Sub 10

Runoff = 2.21 cfs @ 12.09 hrs, Volume= 6,882 cf, Depth= 4.46"
 Routed to Link 4L : Vernal Pool Wetlands

Runoff by SCS TR-20 method, UH=SCS, Weighted-CN, Time Span= 1.00-36.00 hrs, dt= 0.01 hrs
 Type III 24-hr 50-year Rainfall=7.10"

Area (sf)	CN	Description
12,797	98	Paved parking, HSG A
424	30	Woods, Good, HSG A
* 5,312	30	Grass
18,533	77	Weighted Average
5,736		30.95% Pervious Area
12,797		69.05% Impervious Area

Tc (min)	Length (feet)	Slope (ft/ft)	Velocity (ft/sec)	Capacity (cfs)	Description
6.0					Direct Entry,

Subcatchment 10S: Sub 10

Hydrograph

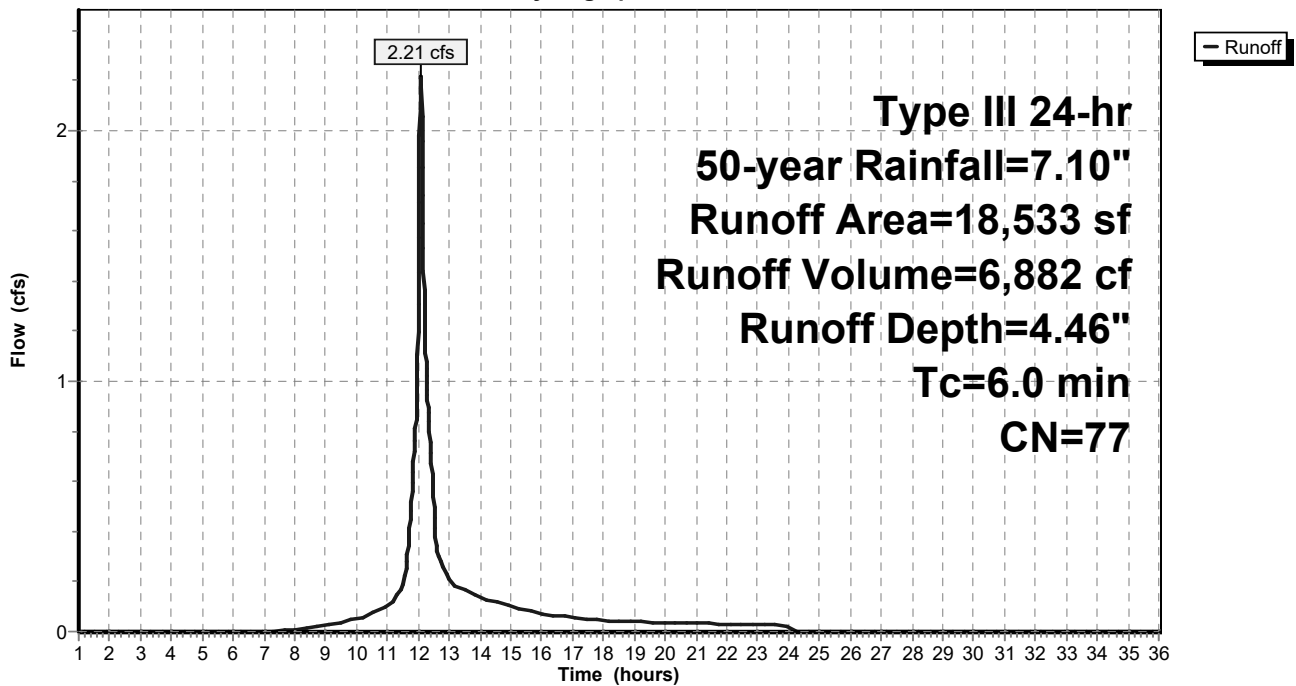

Spofford Pre-Development

Prepared by Weston & Sampson

HydroCAD® 10.10-6a s/n 00455 © 2020 HydroCAD Software Solutions LLC

Type III 24-hr 50-year Rainfall=7.10"

Printed 11/2/2021

Page 65

Summary for Subcatchment 11S: Sub 11

Runoff = 4.30 cfs @ 12.09 hrs, Volume= 13,328 cf, Depth= 4.13"
 Routed to Link 4L : Vernal Pool Wetlands

Runoff by SCS TR-20 method, UH=SCS, Weighted-CN, Time Span= 1.00-36.00 hrs, dt= 0.01 hrs
 Type III 24-hr 50-year Rainfall=7.10"

Area (sf)	CN	Description
5,533	98	Paved parking, HSG A
4,499	30	Woods, Good, HSG A
* 9,450	30	Grass
* 19,248	98	Compacted Gravel
38,730	74	Weighted Average
13,949		36.02% Pervious Area
24,781		63.98% Impervious Area

Tc (min)	Length (feet)	Slope (ft/ft)	Velocity (ft/sec)	Capacity (cfs)	Description
6.0					Direct Entry,

Subcatchment 11S: Sub 11

Hydrograph

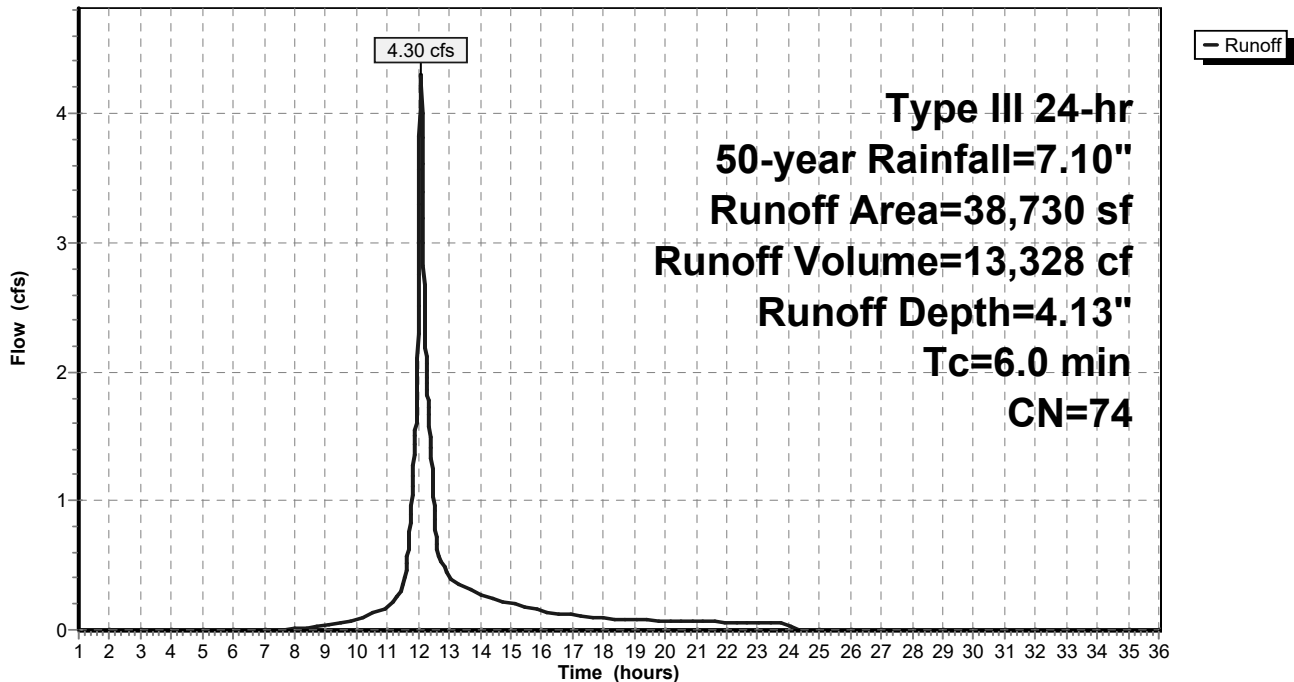

Summary for Link 1L: Leaching CB

Inflow Area = 9,774 sf, 0.00% Impervious, Inflow Depth = 0.23" for 50-year event
Inflow = 0.01 cfs @ 13.70 hrs, Volume= 187 cf
Primary = 0.01 cfs @ 13.70 hrs, Volume= 187 cf, Atten= 0%, Lag= 0.0 min

Primary outflow = Inflow, Time Span= 1.00-36.00 hrs, dt= 0.01 hrs

Link 1L: Leaching CB

Hydrograph

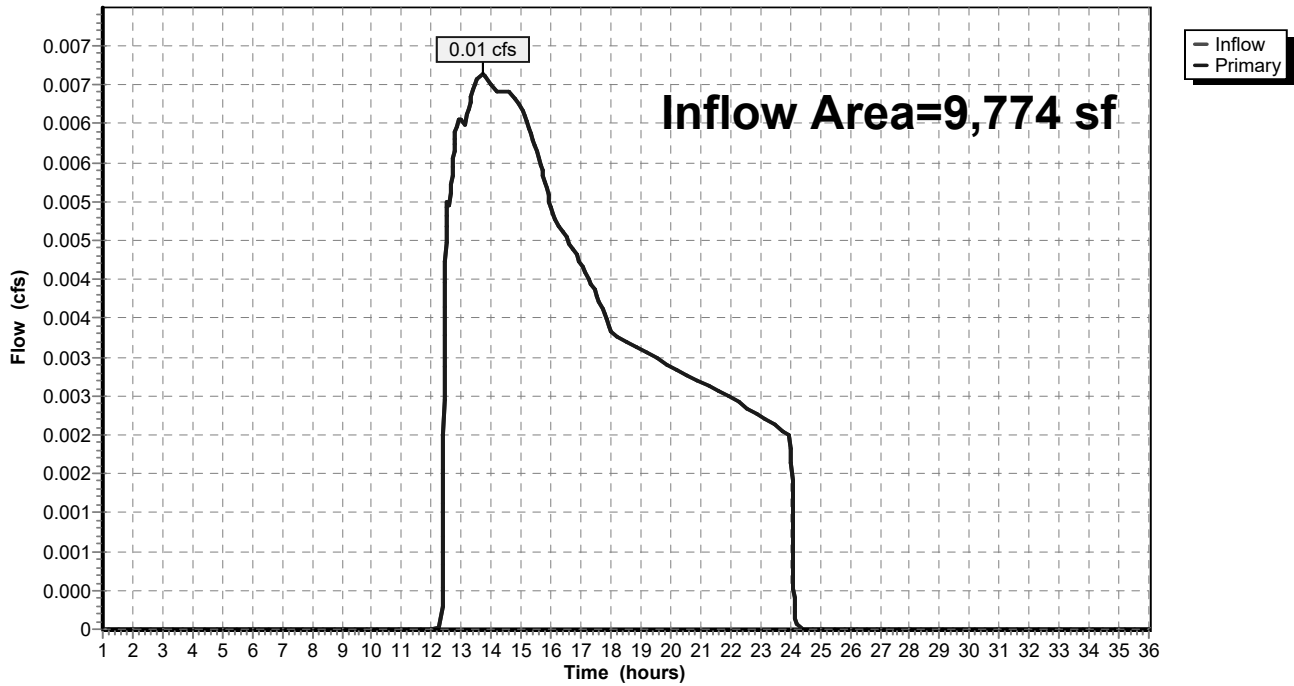

Summary for Link 2L: Isolated Wetlands

Inflow Area = 16,497 sf, 9.02% Impervious, Inflow Depth = 0.59" for 50-year event
Inflow = 0.10 cfs @ 12.32 hrs, Volume= 810 cf
Primary = 0.10 cfs @ 12.32 hrs, Volume= 810 cf, Atten= 0%, Lag= 0.0 min

Primary outflow = Inflow, Time Span= 1.00-36.00 hrs, dt= 0.01 hrs

Link 2L: Isolated Wetlands

Hydrograph

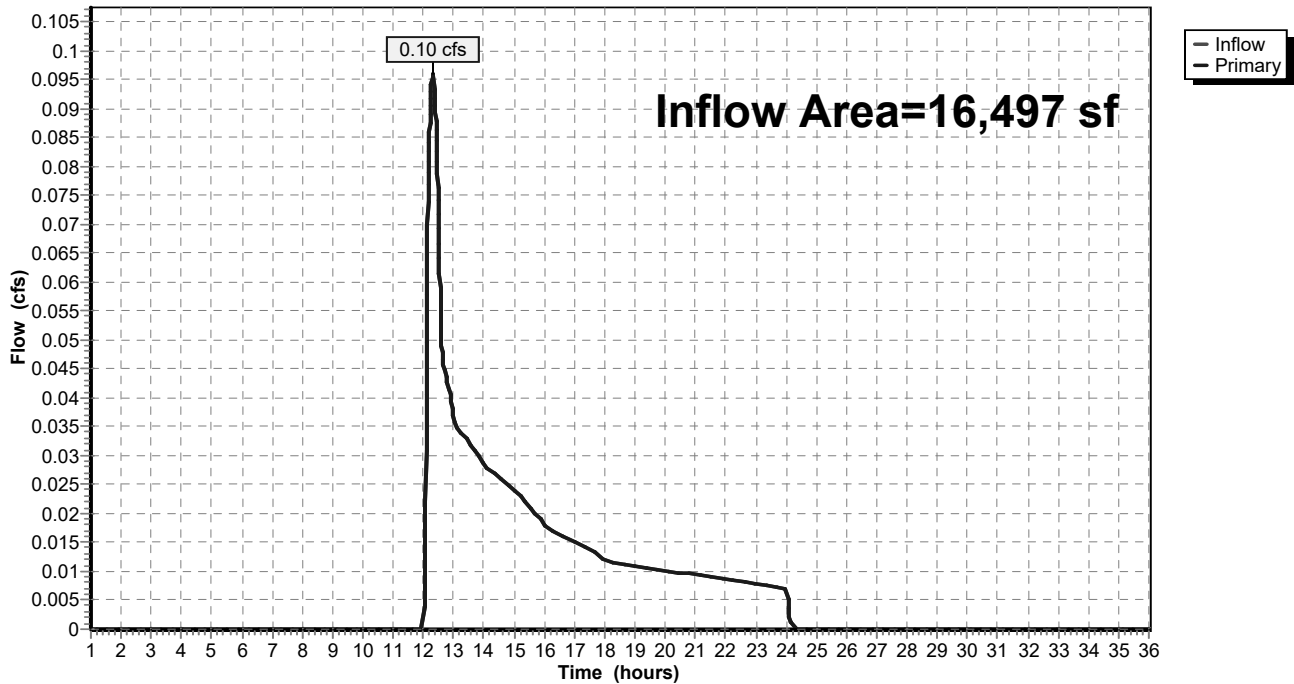

Summary for Link 3L: Spofford Pond Wetlands

Inflow Area = 55,898 sf, 22.84% Impervious, Inflow Depth = 1.33" for 50-year event
Inflow = 1.56 cfs @ 12.11 hrs, Volume= 6,187 cf
Primary = 1.56 cfs @ 12.11 hrs, Volume= 6,187 cf, Atten= 0%, Lag= 0.0 min

Primary outflow = Inflow, Time Span= 1.00-36.00 hrs, dt= 0.01 hrs

Link 3L: Spofford Pond Wetlands

Hydrograph

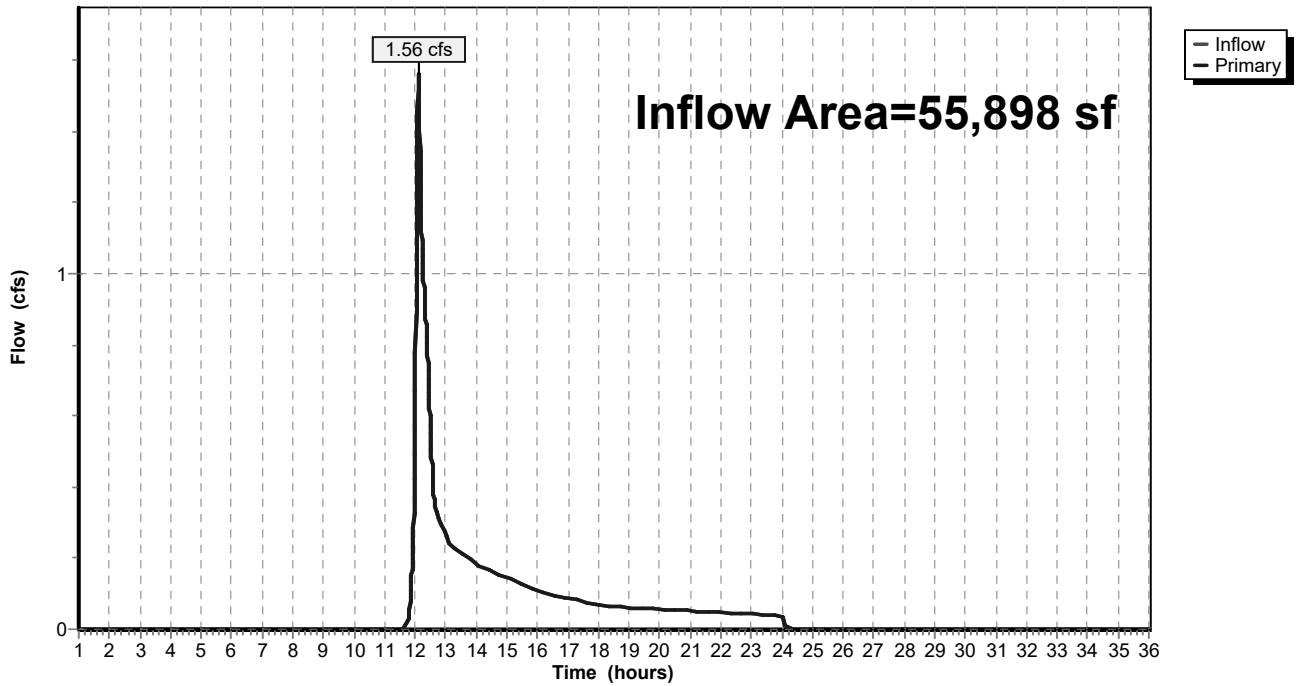

Summary for Link 4L: Vernal Pool Wetlands

Inflow Area = 225,348 sf, 85.58% Impervious, Inflow Depth > 5.76" for 50-year event
Inflow = 31.84 cfs @ 12.08 hrs, Volume= 108,076 cf
Primary = 31.84 cfs @ 12.08 hrs, Volume= 108,076 cf, Atten= 0%, Lag= 0.0 min
Routed to nonexistent node 25L

Primary outflow = Inflow, Time Span= 1.00-36.00 hrs, dt= 0.01 hrs

Link 4L: Vernal Pool Wetlands

Hydrograph

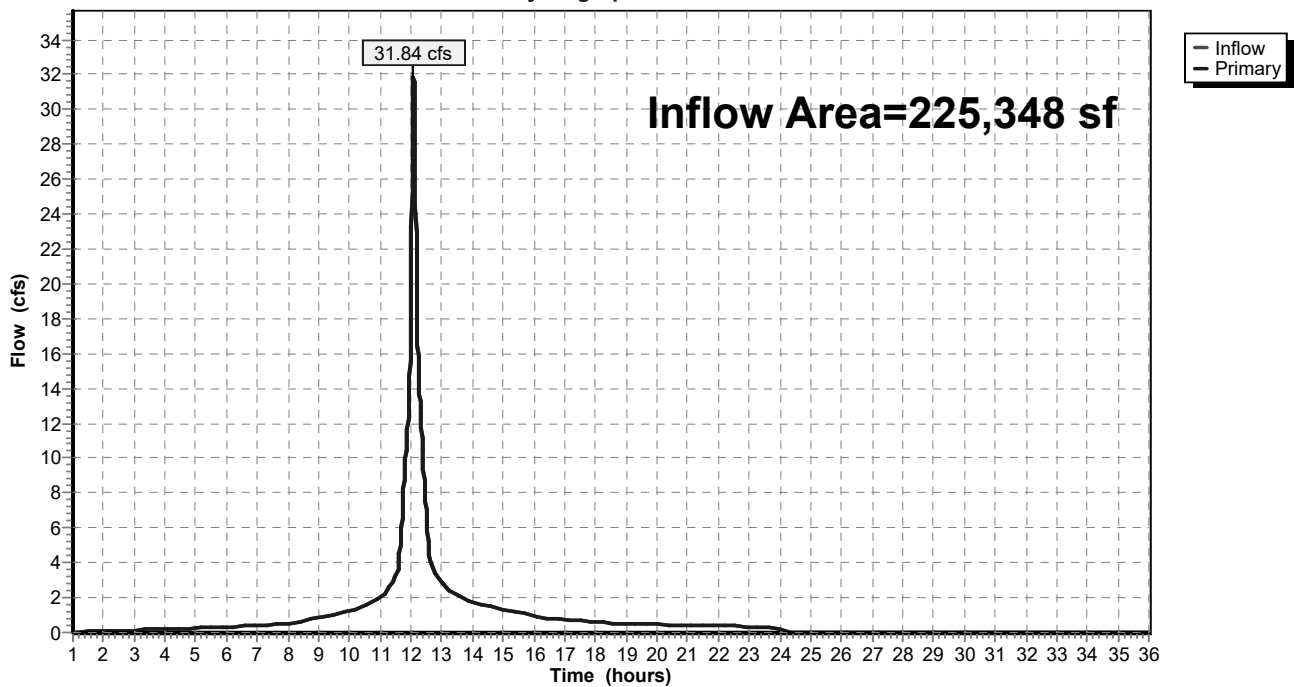

Time span=1.00-36.00 hrs, dt=0.01 hrs, 3501 points
 Runoff by SCS TR-20 method, UH=SCS, Weighted-CN
 Reach routing by Dyn-Stor-Ind method - Pond routing by Dyn-Stor-Ind method

Subcatchment1S: Roof	Runoff Area=71,161 sf 100.00% Impervious Runoff Depth>8.06" Tc=6.0 min CN=98 Runoff=13.31 cfs 47,767 cf
Subcatchment2S: Sub 2	Runoff Area=9,774 sf 0.00% Impervious Runoff Depth=0.49" Tc=6.0 min CN=30 Runoff=0.04 cfs 399 cf
Subcatchment3S: Sub 3	Runoff Area=24,730 sf 73.09% Impervious Runoff Depth=5.91" Tc=6.0 min CN=80 Runoff=3.86 cfs 12,173 cf
Subcatchment4S: Sub 4	Runoff Area=13,456 sf 63.32% Impervious Runoff Depth=5.08" Tc=6.0 min CN=73 Runoff=1.83 cfs 5,693 cf
Subcatchment5S: Sub 5	Runoff Area=28,834 sf 23.36% Impervious Runoff Depth=2.00" Tc=6.0 min CN=46 Runoff=1.36 cfs 4,812 cf
Subcatchment6S: Sub 6	Runoff Area=27,064 sf 22.29% Impervious Runoff Depth=1.90" Tc=6.0 min CN=45 Runoff=1.18 cfs 4,278 cf
Subcatchment7S: Sub 7	Runoff Area=18,136 sf 97.29% Impervious Runoff Depth=7.82" Tc=6.0 min CN=96 Runoff=3.37 cfs 11,819 cf
Subcatchment8S: Sub 8	Runoff Area=16,497 sf 9.02% Impervious Runoff Depth=1.00" Tc=6.0 min CN=36 Runoff=0.24 cfs 1,374 cf
Subcatchment9S: Sub 9	Runoff Area=40,602 sf 98.20% Impervious Runoff Depth>7.94" Tc=6.0 min CN=97 Runoff=7.58 cfs 26,863 cf
Subcatchment10S: Sub 10	Runoff Area=18,533 sf 69.05% Impervious Runoff Depth=5.55" Tc=6.0 min CN=77 Runoff=2.74 cfs 8,572 cf
Subcatchment11S: Sub 11	Runoff Area=38,730 sf 63.98% Impervious Runoff Depth=5.19" Tc=6.0 min CN=74 Runoff=5.40 cfs 16,766 cf
Link 1L: Leaching CB	Inflow=0.04 cfs 399 cf Primary=0.04 cfs 399 cf
Link 2L: Isolated Wetlands	Inflow=0.24 cfs 1,374 cf Primary=0.24 cfs 1,374 cf
Link 3L: Spofford Pond Wetlands	Inflow=2.54 cfs 9,089 cf Primary=2.54 cfs 9,089 cf
Link 4L: Vernal Pool Wetlands	Inflow=38.09 cfs 129,653 cf Primary=38.09 cfs 129,653 cf

Total Runoff Area = 307,517 sf Runoff Volume = 140,516 cf Average Runoff Depth = 5.48"
32.65% Pervious = 100,409 sf 67.35% Impervious = 207,108 sf

Spofford Pre-Development

Prepared by Weston & Sampson

HydroCAD® 10.10-6a s/n 00455 © 2020 HydroCAD Software Solutions LLC

Type III 24-hr 100-year Rainfall=8.30"

Printed 11/2/2021

Page 71

Summary for Subcatchment 1S: Roof

Runoff = 13.31 cfs @ 12.08 hrs, Volume= 47,767 cf, Depth> 8.06"

Routed to Link 4L : Vernal Pool Wetlands

Runoff by SCS TR-20 method, UH=SCS, Weighted-CN, Time Span= 1.00-36.00 hrs, dt= 0.01 hrs
Type III 24-hr 100-year Rainfall=8.30"

Area (sf)	CN	Description
71,161	98	Roofs, HSG A
71,161		100.00% Impervious Area

Tc (min)	Length (feet)	Slope (ft/ft)	Velocity (ft/sec)	Capacity (cfs)	Description
6.0					Direct Entry,

Subcatchment 1S: Roof

Hydrograph

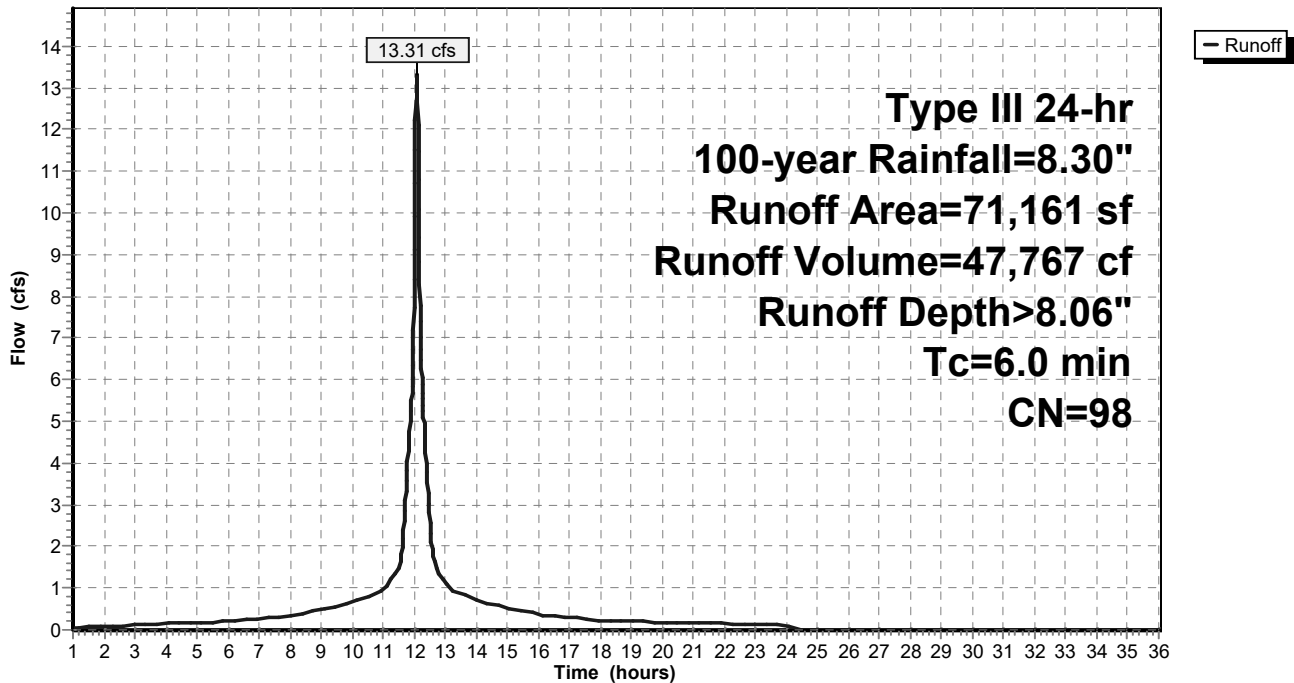

Spofford Pre-Development

Prepared by Weston & Sampson

HydroCAD® 10.10-6a s/n 00455 © 2020 HydroCAD Software Solutions LLC

Type III 24-hr 100-year Rainfall=8.30"

Printed 11/2/2021

Page 72

Summary for Subcatchment 2S: Sub 2

Runoff = 0.04 cfs @ 12.39 hrs, Volume= 399 cf, Depth= 0.49"

Routed to Link 1L : Leaching CB

Runoff by SCS TR-20 method, UH=SCS, Weighted-CN, Time Span= 1.00-36.00 hrs, dt= 0.01 hrs
Type III 24-hr 100-year Rainfall=8.30"

Area (sf)	CN	Description
* 9,774	30	Grass
9,774		100.00% Pervious Area

Tc (min)	Length (feet)	Slope (ft/ft)	Velocity (ft/sec)	Capacity (cfs)	Description
6.0					Direct Entry,

Subcatchment 2S: Sub 2

Hydrograph

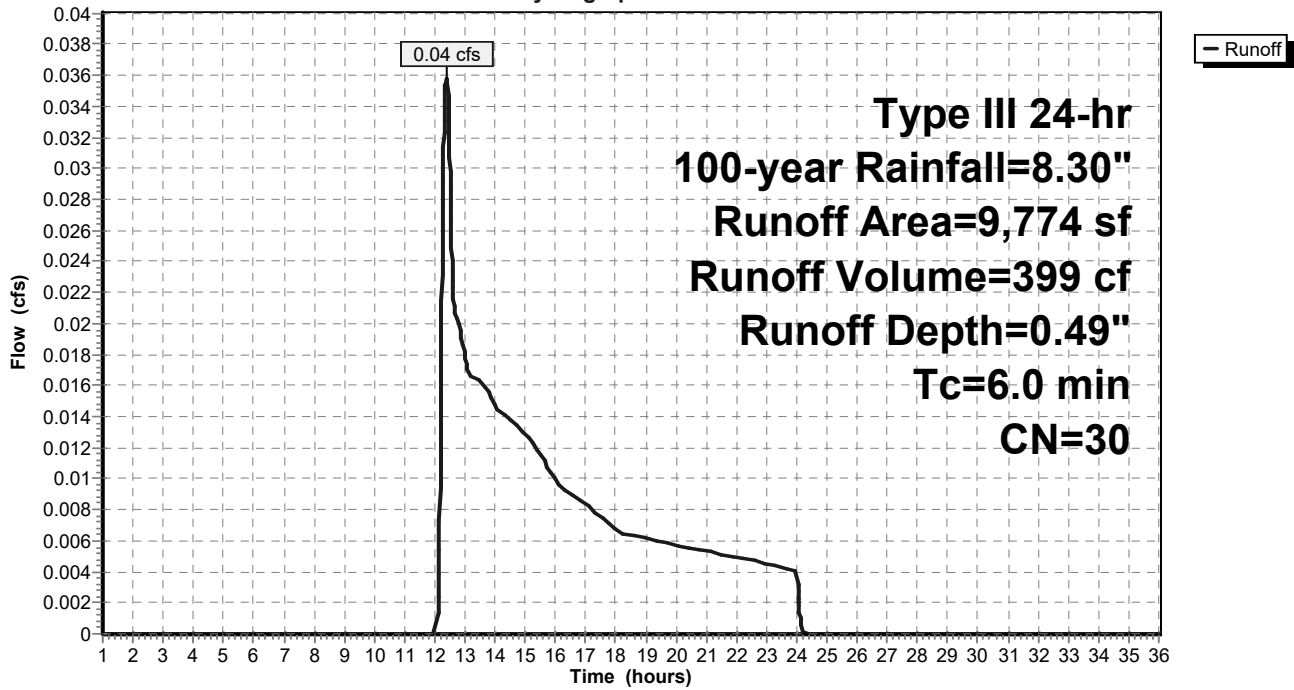

Spofford Pre-Development

Prepared by Weston & Sampson

HydroCAD® 10.10-6a s/n 00455 © 2020 HydroCAD Software Solutions LLC

Type III 24-hr 100-year Rainfall=8.30"

Printed 11/2/2021

Page 73

Summary for Subcatchment 3S: Sub 3

Runoff = 3.86 cfs @ 12.09 hrs, Volume= 12,173 cf, Depth= 5.91"

Routed to Link 4L : Vernal Pool Wetlands

Runoff by SCS TR-20 method, UH=SCS, Weighted-CN, Time Span= 1.00-36.00 hrs, dt= 0.01 hrs
Type III 24-hr 100-year Rainfall=8.30"

Area (sf)	CN	Description
8,972	98	Paved parking, HSG A
* 9,104	98	Turf (impervious)
* 5,760	30	Grass
894	30	Woods, Good, HSG A
24,730	80	Weighted Average
6,654		26.91% Pervious Area
18,076		73.09% Impervious Area

Tc (min)	Length (feet)	Slope (ft/ft)	Velocity (ft/sec)	Capacity (cfs)	Description
6.0					Direct Entry,

Subcatchment 3S: Sub 3

Hydrograph

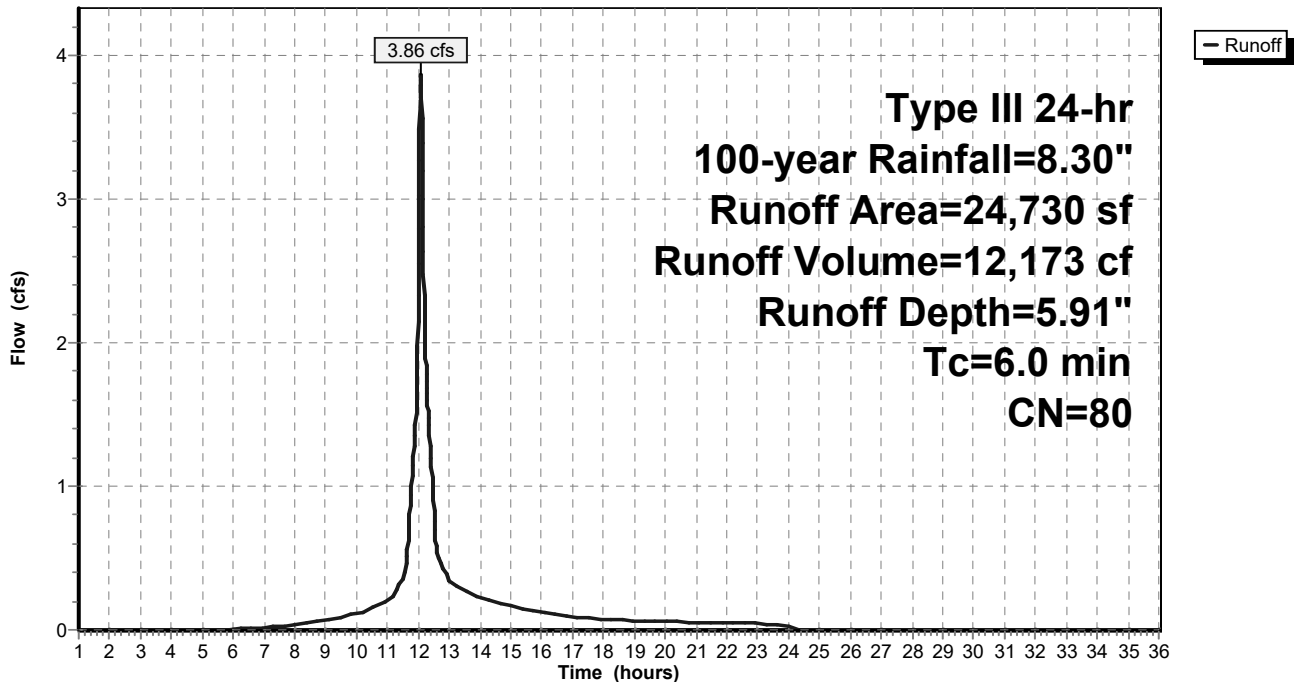

Spofford Pre-Development

Prepared by Weston & Sampson

HydroCAD® 10.10-6a s/n 00455 © 2020 HydroCAD Software Solutions LLC

Type III 24-hr 100-year Rainfall=8.30"

Printed 11/2/2021

Page 74

Summary for Subcatchment 4S: Sub 4

Runoff = 1.83 cfs @ 12.09 hrs, Volume= 5,693 cf, Depth= 5.08"

Routed to Link 4L : Vernal Pool Wetlands

Runoff by SCS TR-20 method, UH=SCS, Weighted-CN, Time Span= 1.00-36.00 hrs, dt= 0.01 hrs
 Type III 24-hr 100-year Rainfall=8.30"

Area (sf)	CN	Description
8,521	98	Paved parking, HSG A
2,064	30	Woods, Good, HSG A
* 2,871	30	Grass
13,456	73	Weighted Average
4,935		36.68% Pervious Area
8,521		63.32% Impervious Area

Tc (min)	Length (feet)	Slope (ft/ft)	Velocity (ft/sec)	Capacity (cfs)	Description
6.0					Direct Entry,

Subcatchment 4S: Sub 4

Hydrograph

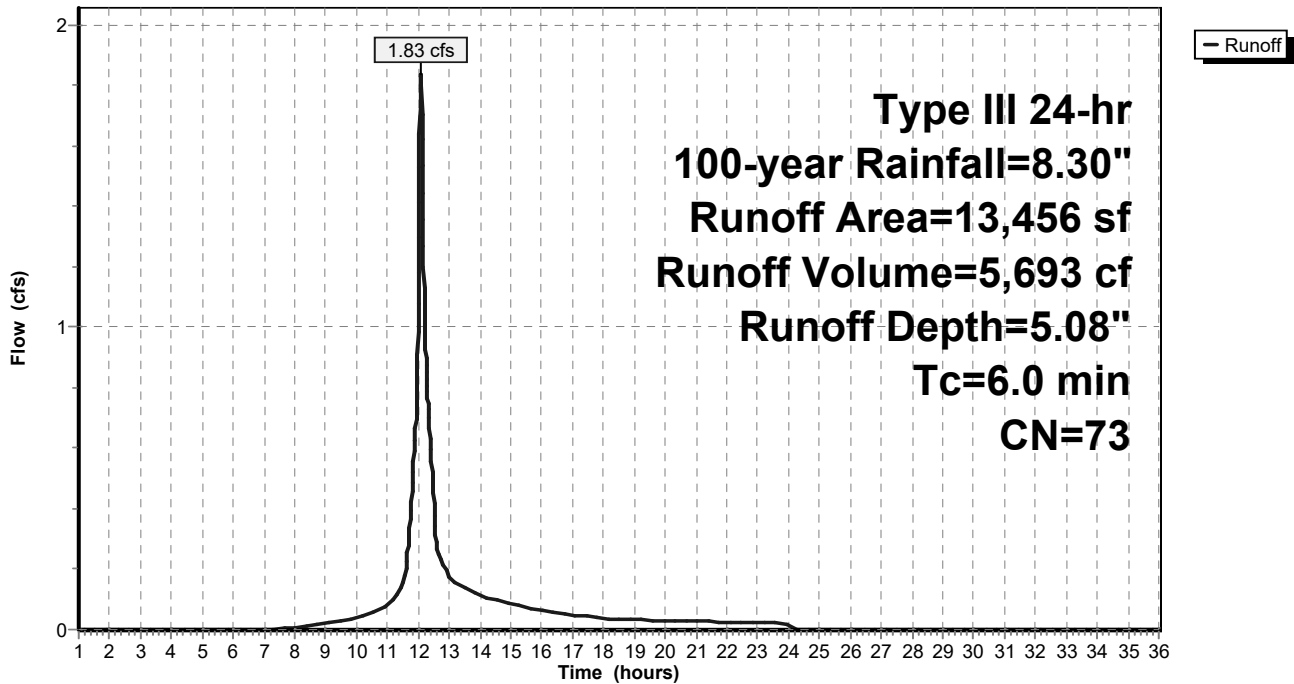

Spofford Pre-Development

Prepared by Weston & Sampson

HydroCAD® 10.10-6a s/n 00455 © 2020 HydroCAD Software Solutions LLC

Type III 24-hr 100-year Rainfall=8.30"

Printed 11/2/2021

Page 75

Summary for Subcatchment 5S: Sub 5

Runoff = 1.36 cfs @ 12.10 hrs, Volume= 4,812 cf, Depth= 2.00"

Routed to Link 3L : Spofford Pond Wetlands

Runoff by SCS TR-20 method, UH=SCS, Weighted-CN, Time Span= 1.00-36.00 hrs, dt= 0.01 hrs
 Type III 24-hr 100-year Rainfall=8.30"

Area (sf)	CN	Description
6,737	98	Paved parking, HSG A
9,957	30	Woods, Good, HSG A
* 12,140	30	Grass
28,834	46	Weighted Average
22,097		76.64% Pervious Area
6,737		23.36% Impervious Area

Tc (min)	Length (feet)	Slope (ft/ft)	Velocity (ft/sec)	Capacity (cfs)	Description
6.0					Direct Entry,

Subcatchment 5S: Sub 5

Hydrograph

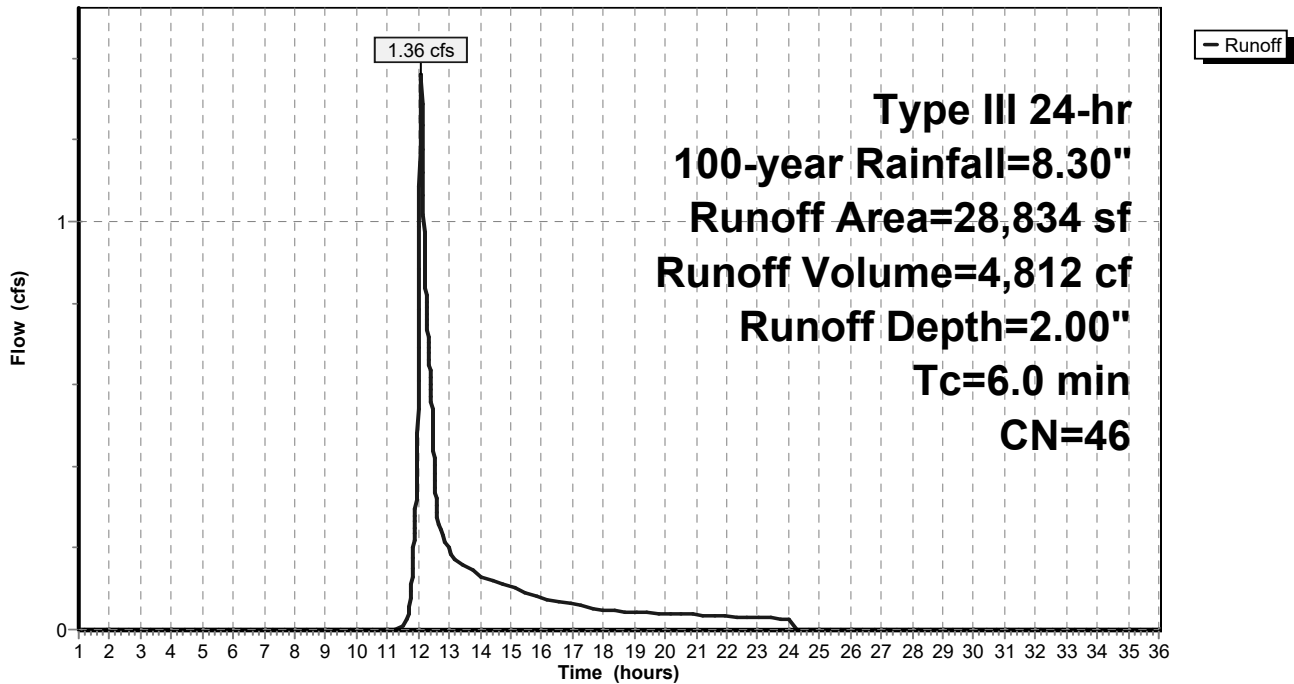

Summary for Subcatchment 6S: Sub 6

Runoff = 1.18 cfs @ 12.10 hrs, Volume= 4,278 cf, Depth= 1.90"
 Routed to Link 3L : Spofford Pond Wetlands

Runoff by SCS TR-20 method, UH=SCS, Weighted-CN, Time Span= 1.00-36.00 hrs, dt= 0.01 hrs
 Type III 24-hr 100-year Rainfall=8.30"

Area (sf)	CN	Description
6,032	98	Paved parking, HSG A
* 21,032	30	Grass
27,064	45	Weighted Average
21,032		77.71% Pervious Area
6,032		22.29% Impervious Area

Tc (min)	Length (feet)	Slope (ft/ft)	Velocity (ft/sec)	Capacity (cfs)	Description
6.0					Direct Entry,

Subcatchment 6S: Sub 6

Hydrograph

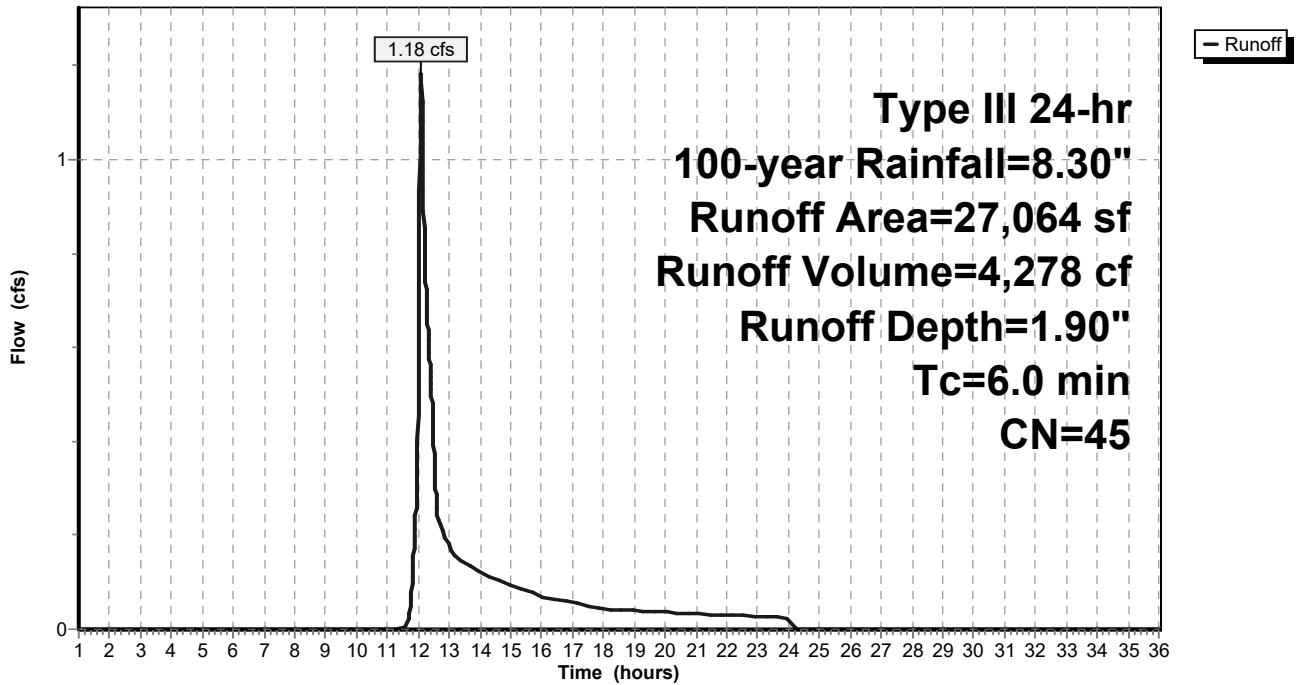

Spofford Pre-Development

Prepared by Weston & Sampson

HydroCAD® 10.10-6a s/n 00455 © 2020 HydroCAD Software Solutions LLC

Type III 24-hr 100-year Rainfall=8.30"

Printed 11/2/2021

Page 77

Summary for Subcatchment 7S: Sub 7

Runoff = 3.37 cfs @ 12.08 hrs, Volume= 11,819 cf, Depth= 7.82"
 Routed to Link 4L : Vernal Pool Wetlands

Runoff by SCS TR-20 method, UH=SCS, Weighted-CN, Time Span= 1.00-36.00 hrs, dt= 0.01 hrs
 Type III 24-hr 100-year Rainfall=8.30"

Area (sf)	CN	Description
17,644	98	Paved parking, HSG A
* 492	30	Grass
18,136	96	Weighted Average
492		2.71% Pervious Area
17,644		97.29% Impervious Area

Tc (min)	Length (feet)	Slope (ft/ft)	Velocity (ft/sec)	Capacity (cfs)	Description
6.0					Direct Entry,

Subcatchment 7S: Sub 7

Hydrograph

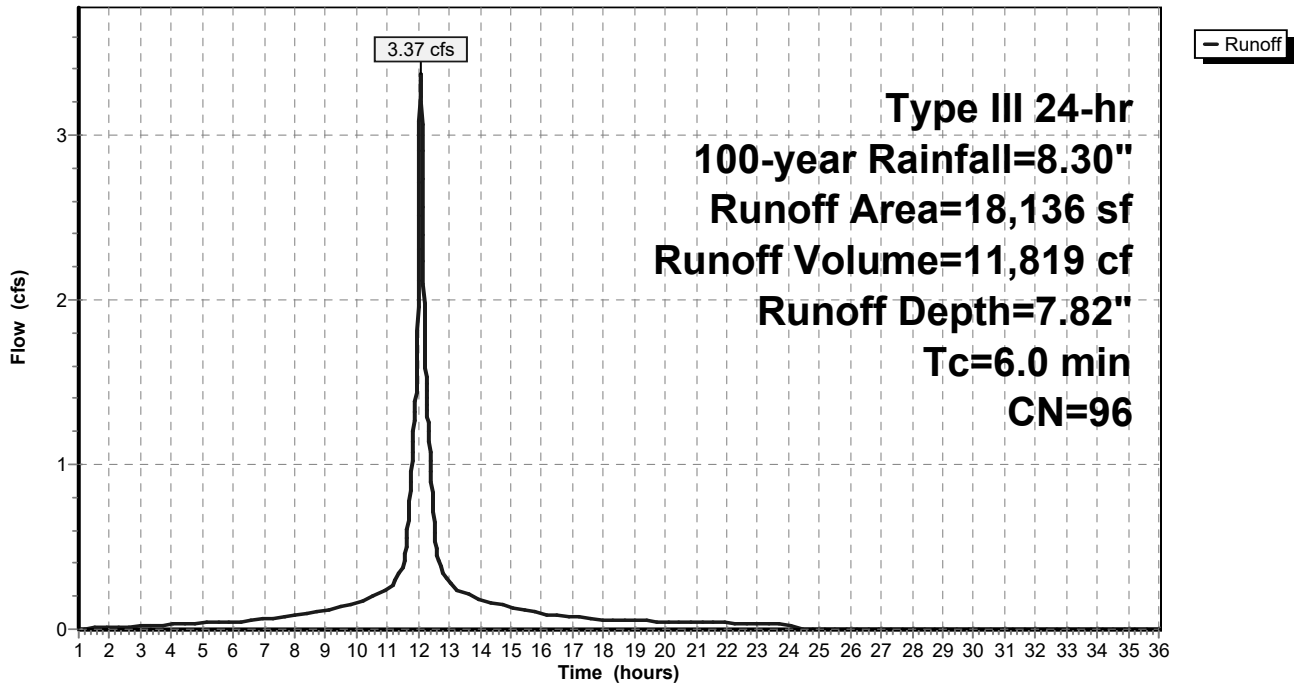

Summary for Subcatchment 8S: Sub 8

Runoff = 0.24 cfs @ 12.13 hrs, Volume= 1,374 cf, Depth= 1.00"
 Routed to Link 2L : Isolated Wetlands

Runoff by SCS TR-20 method, UH=SCS, Weighted-CN, Time Span= 1.00-36.00 hrs, dt= 0.01 hrs
 Type III 24-hr 100-year Rainfall=8.30"

Area (sf)	CN	Description
1,488	98	Paved parking, HSG A
* 15,009	30	Grass
16,497	36	Weighted Average
15,009		90.98% Pervious Area
1,488		9.02% Impervious Area

Tc (min)	Length (feet)	Slope (ft/ft)	Velocity (ft/sec)	Capacity (cfs)	Description
6.0					Direct Entry,

Subcatchment 8S: Sub 8

Hydrograph

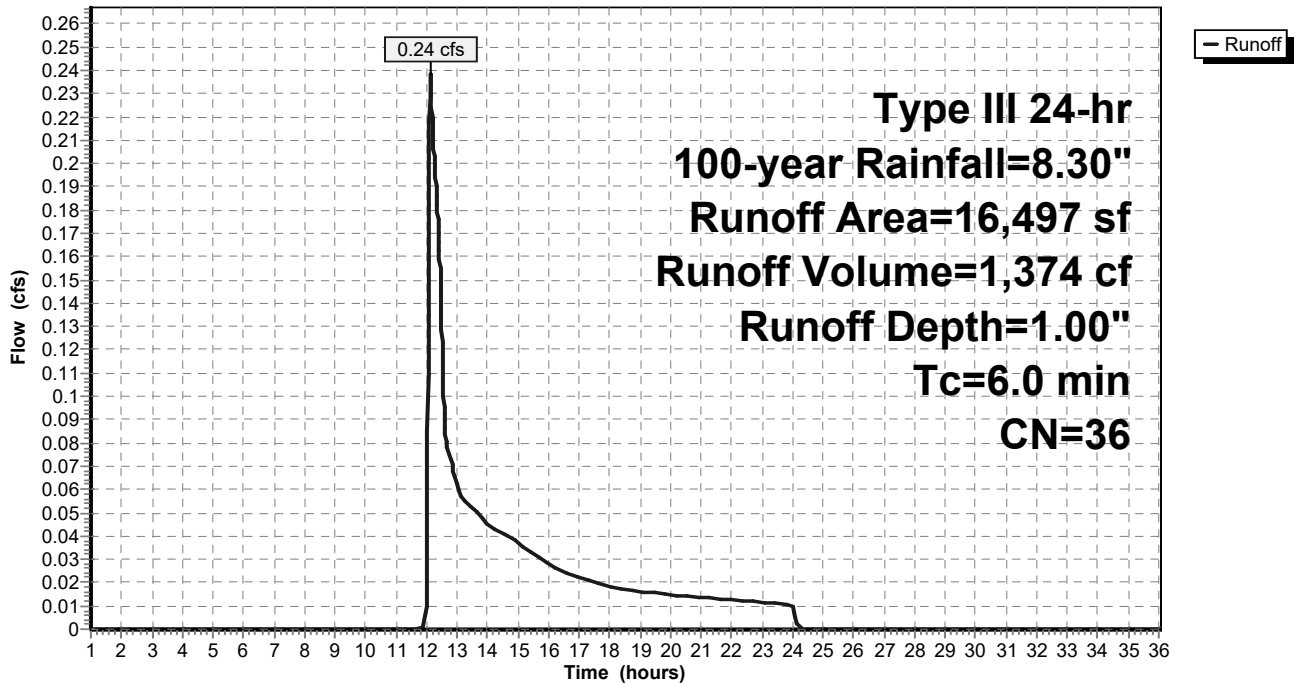

Spofford Pre-Development

Prepared by Weston & Sampson

HydroCAD® 10.10-6a s/n 00455 © 2020 HydroCAD Software Solutions LLC

Type III 24-hr 100-year Rainfall=8.30"

Printed 11/2/2021

Page 79

Summary for Subcatchment 9S: Sub 9

Runoff = 7.58 cfs @ 12.08 hrs, Volume= 26,863 cf, Depth> 7.94"
 Routed to Link 4L : Vernal Pool Wetlands

Runoff by SCS TR-20 method, UH=SCS, Weighted-CN, Time Span= 1.00-36.00 hrs, dt= 0.01 hrs
 Type III 24-hr 100-year Rainfall=8.30"

Area (sf)	CN	Description
39,871	98	Paved parking, HSG A
* 731	30	Grass
40,602	97	Weighted Average
731		1.80% Pervious Area
39,871		98.20% Impervious Area

Tc (min)	Length (feet)	Slope (ft/ft)	Velocity (ft/sec)	Capacity (cfs)	Description
6.0					Direct Entry,

Subcatchment 9S: Sub 9

Hydrograph

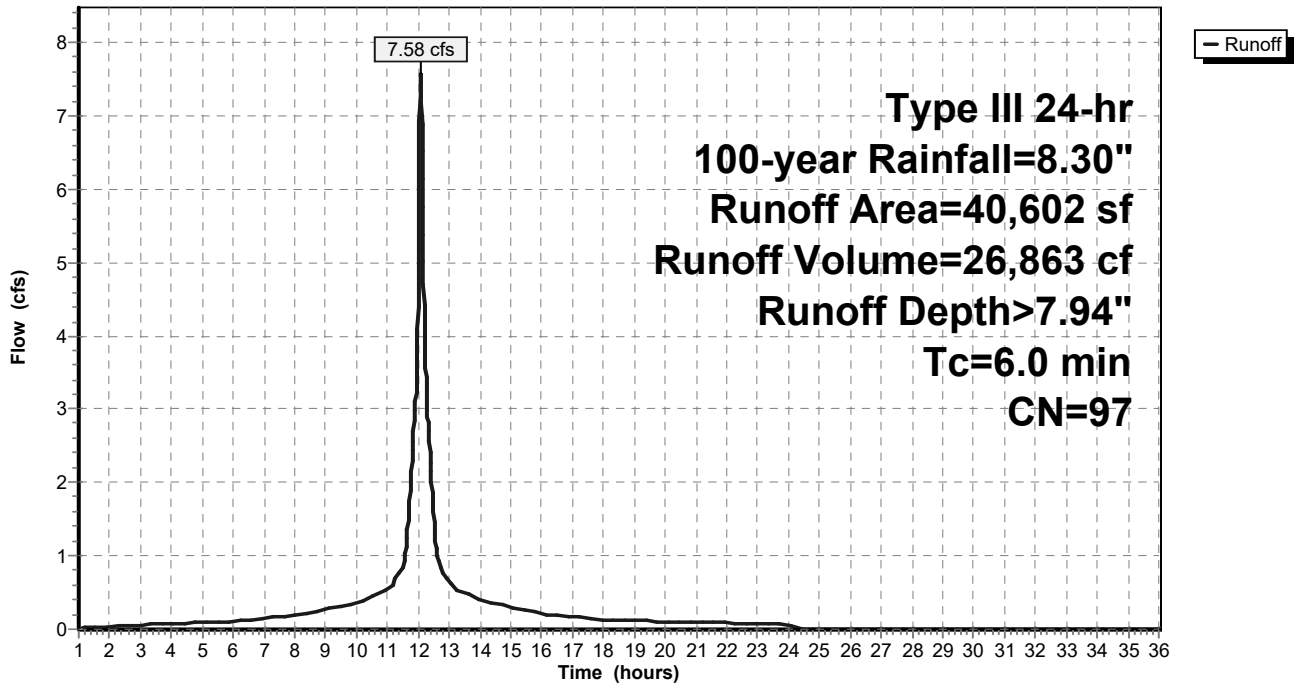

Spofford Pre-Development

Prepared by Weston & Sampson

HydroCAD® 10.10-6a s/n 00455 © 2020 HydroCAD Software Solutions LLC

Type III 24-hr 100-year Rainfall=8.30"

Printed 11/2/2021

Page 80

Summary for Subcatchment 10S: Sub 10

Runoff = 2.74 cfs @ 12.09 hrs, Volume= 8,572 cf, Depth= 5.55"
 Routed to Link 4L : Vernal Pool Wetlands

Runoff by SCS TR-20 method, UH=SCS, Weighted-CN, Time Span= 1.00-36.00 hrs, dt= 0.01 hrs
 Type III 24-hr 100-year Rainfall=8.30"

Area (sf)	CN	Description
12,797	98	Paved parking, HSG A
424	30	Woods, Good, HSG A
* 5,312	30	Grass
18,533	77	Weighted Average
5,736		30.95% Pervious Area
12,797		69.05% Impervious Area

Tc (min)	Length (feet)	Slope (ft/ft)	Velocity (ft/sec)	Capacity (cfs)	Description
6.0					Direct Entry,

Subcatchment 10S: Sub 10

Hydrograph

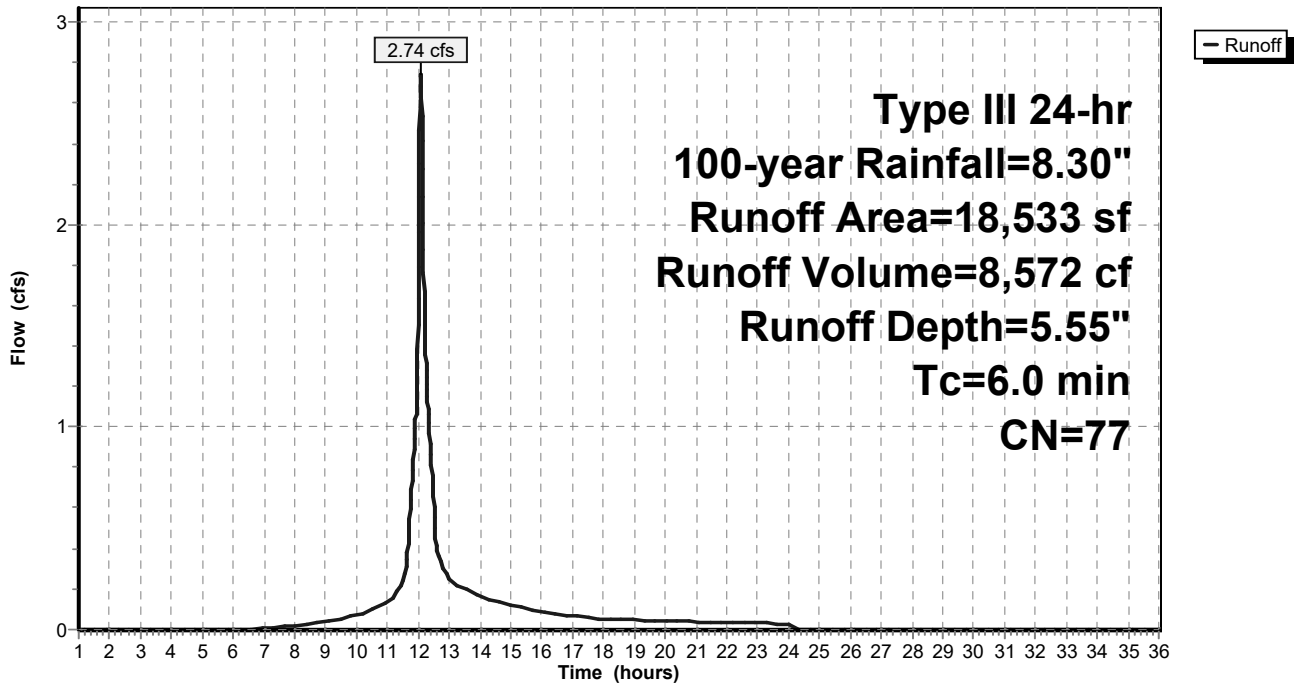

Spofford Pre-Development

Prepared by Weston & Sampson

HydroCAD® 10.10-6a s/n 00455 © 2020 HydroCAD Software Solutions LLC

Type III 24-hr 100-year Rainfall=8.30"

Printed 11/2/2021

Page 81

Summary for Subcatchment 11S: Sub 11

Runoff = 5.40 cfs @ 12.09 hrs, Volume= 16,766 cf, Depth= 5.19"

Routed to Link 4L : Vernal Pool Wetlands

Runoff by SCS TR-20 method, UH=SCS, Weighted-CN, Time Span= 1.00-36.00 hrs, dt= 0.01 hrs
Type III 24-hr 100-year Rainfall=8.30"

Area (sf)	CN	Description
5,533	98	Paved parking, HSG A
4,499	30	Woods, Good, HSG A
* 9,450	30	Grass
* 19,248	98	Compacted Gravel
38,730	74	Weighted Average
13,949		36.02% Pervious Area
24,781		63.98% Impervious Area

Tc (min)	Length (feet)	Slope (ft/ft)	Velocity (ft/sec)	Capacity (cfs)	Description
6.0					Direct Entry,

Subcatchment 11S: Sub 11

Hydrograph

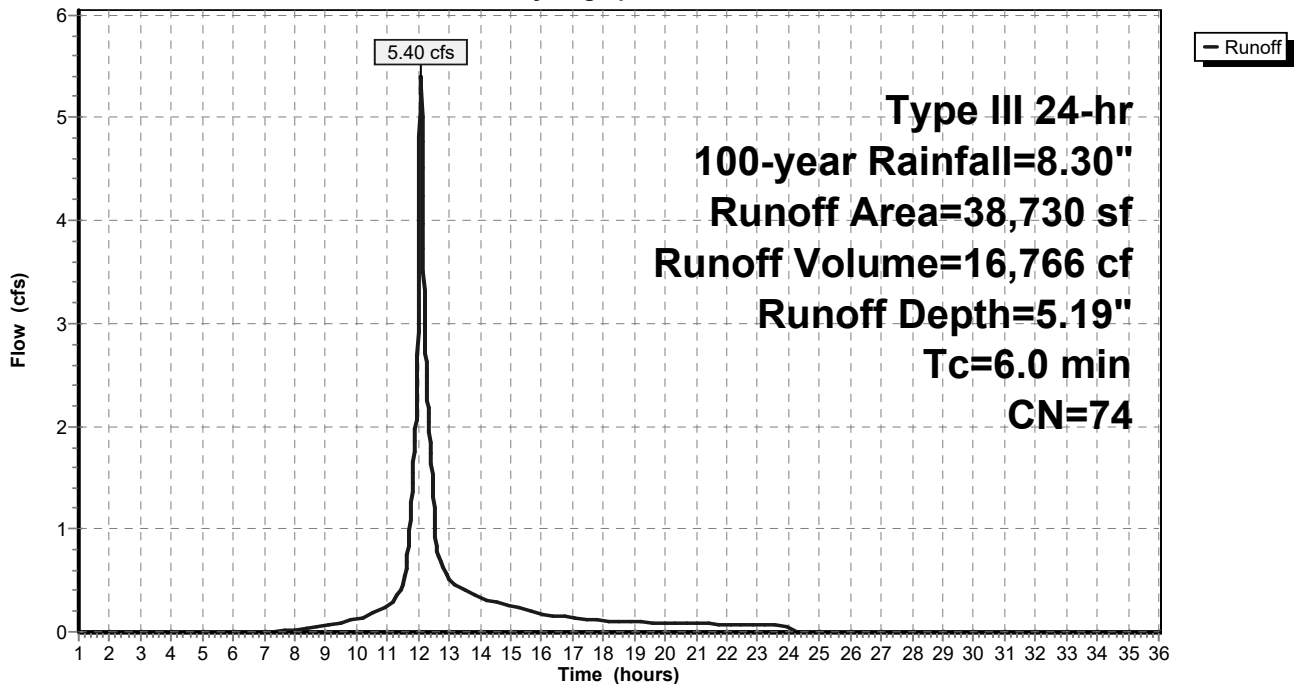

Summary for Link 1L: Leaching CB

Inflow Area = 9,774 sf, 0.00% Impervious, Inflow Depth = 0.49" for 100-year event
Inflow = 0.04 cfs @ 12.39 hrs, Volume= 399 cf
Primary = 0.04 cfs @ 12.39 hrs, Volume= 399 cf, Atten= 0%, Lag= 0.0 min

Primary outflow = Inflow, Time Span= 1.00-36.00 hrs, dt= 0.01 hrs

Link 1L: Leaching CB

Hydrograph

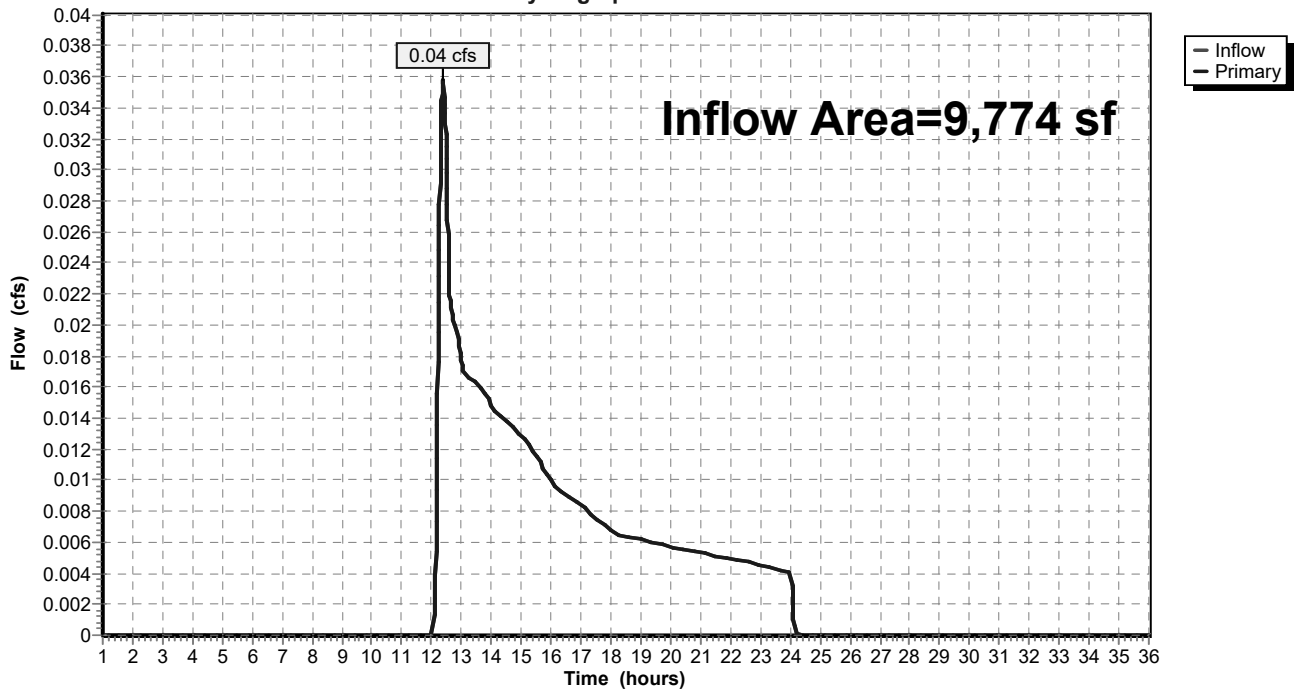

Summary for Link 2L: Isolated Wetlands

Inflow Area = 16,497 sf, 9.02% Impervious, Inflow Depth = 1.00" for 100-year event
Inflow = 0.24 cfs @ 12.13 hrs, Volume= 1,374 cf
Primary = 0.24 cfs @ 12.13 hrs, Volume= 1,374 cf, Atten= 0%, Lag= 0.0 min

Primary outflow = Inflow, Time Span= 1.00-36.00 hrs, dt= 0.01 hrs

Link 2L: Isolated Wetlands

Hydrograph

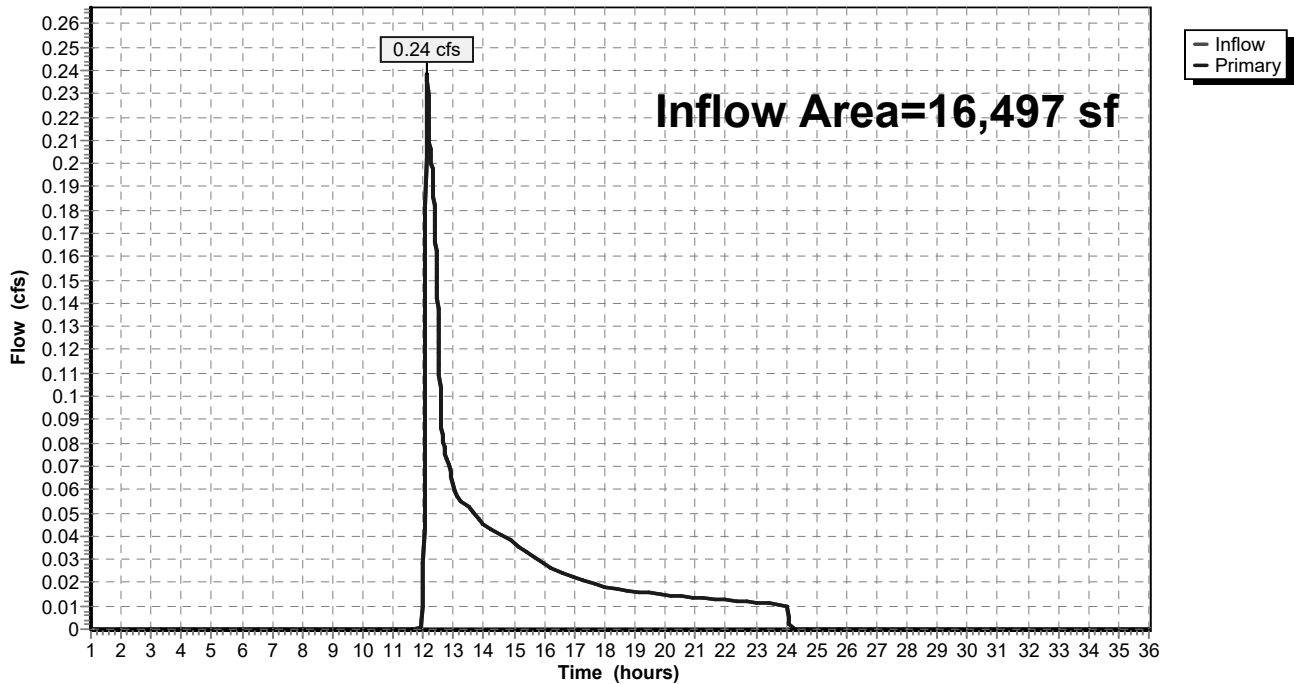

Summary for Link 3L: Spofford Pond Wetlands

Inflow Area = 55,898 sf, 22.84% Impervious, Inflow Depth = 1.95" for 100-year event
Inflow = 2.54 cfs @ 12.10 hrs, Volume= 9,089 cf
Primary = 2.54 cfs @ 12.10 hrs, Volume= 9,089 cf, Atten= 0%, Lag= 0.0 min

Primary outflow = Inflow, Time Span= 1.00-36.00 hrs, dt= 0.01 hrs

Link 3L: Spofford Pond Wetlands

Hydrograph

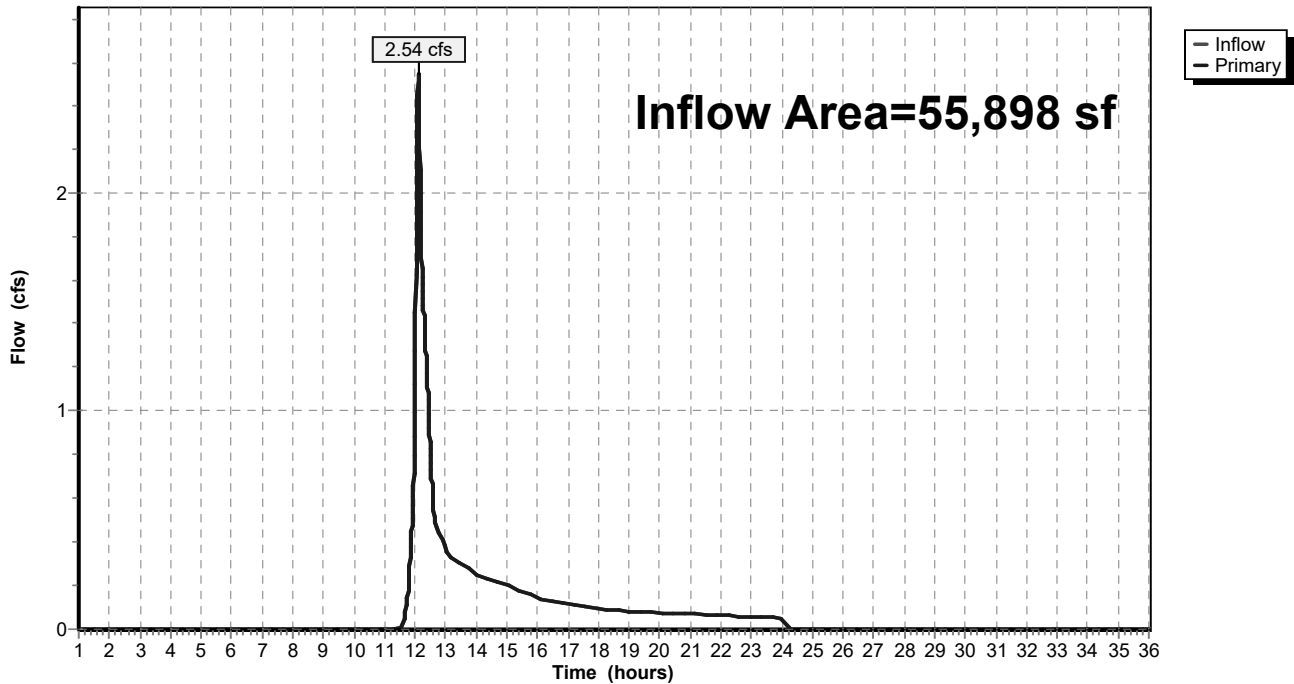

Summary for Link 4L: Vernal Pool Wetlands

Inflow Area = 225,348 sf, 85.58% Impervious, Inflow Depth > 6.90" for 100-year event
Inflow = 38.09 cfs @ 12.08 hrs, Volume= 129,653 cf
Primary = 38.09 cfs @ 12.08 hrs, Volume= 129,653 cf, Atten= 0%, Lag= 0.0 min
Routed to nonexistent node 25L

Primary outflow = Inflow, Time Span= 1.00-36.00 hrs, dt= 0.01 hrs

Link 4L: Vernal Pool Wetlands

Hydrograph

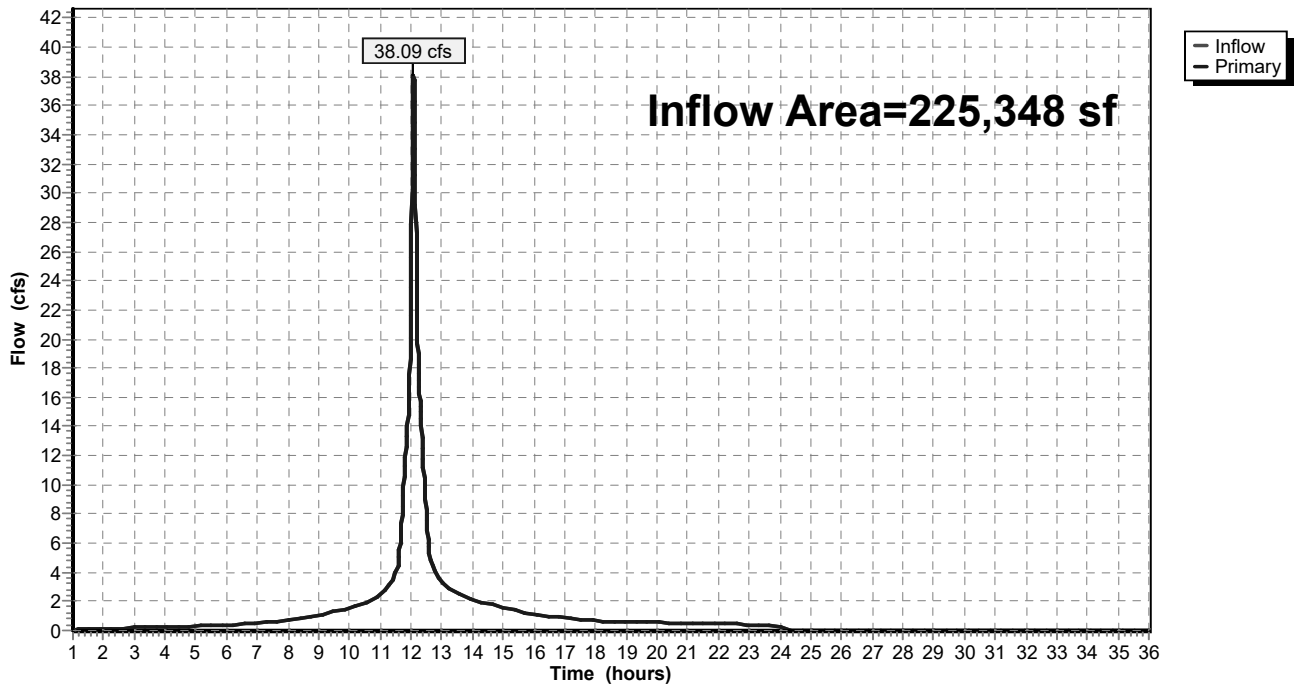

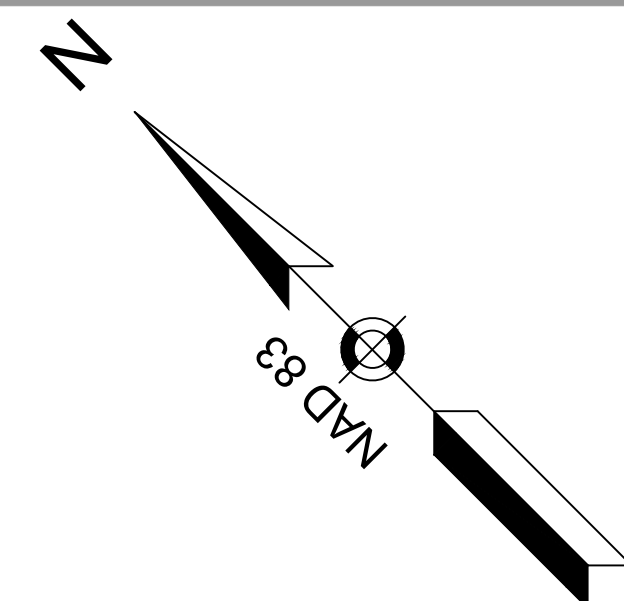
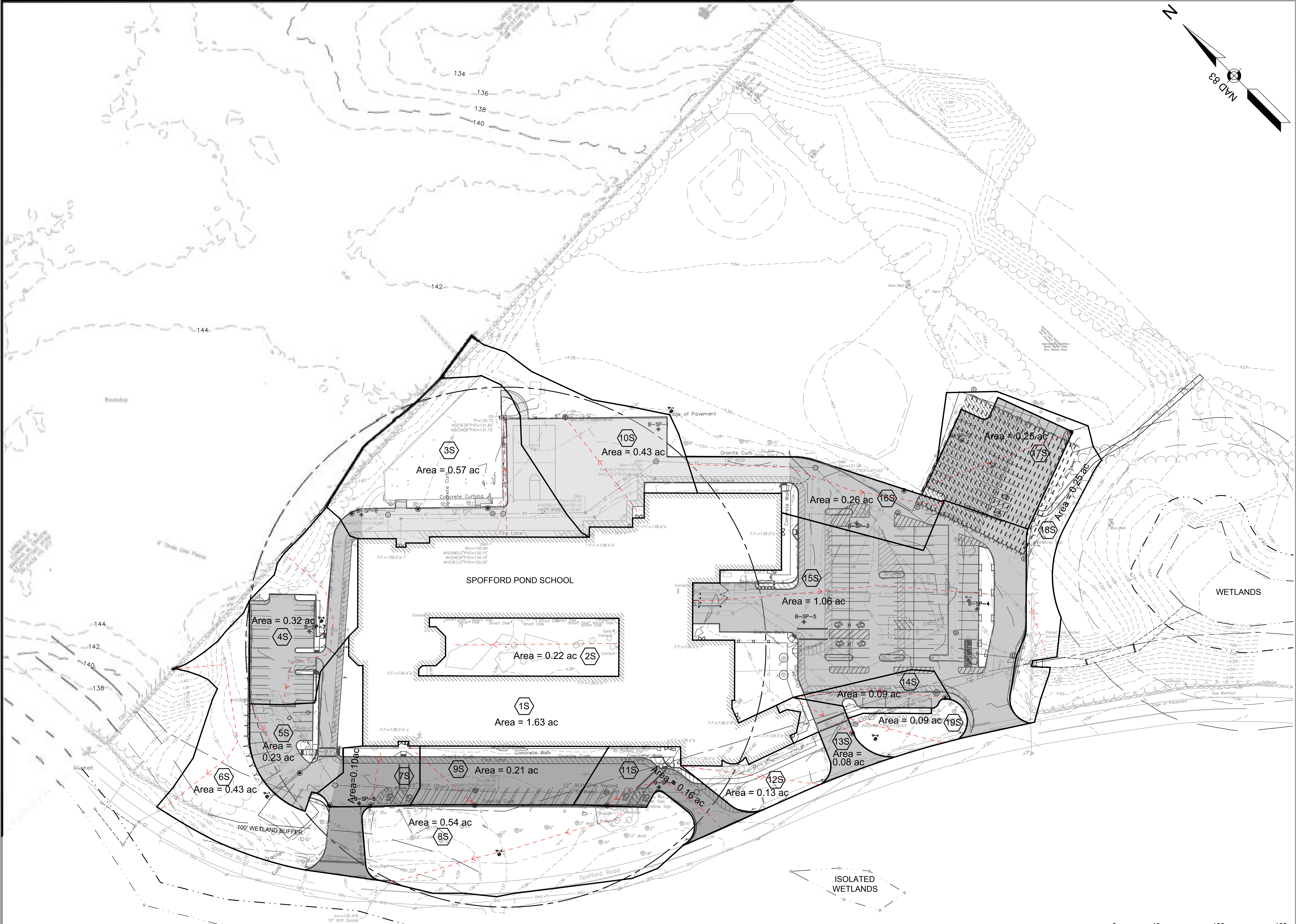

Project:
**BOXFORD PUBLIC
 SCHOOLS SITE
 RENOVATION PROJECT**

**TOWN OF BOXFORD
 MASSACHUSETTS**

SPOFFORD POND SCHOOL
 31 SPOFFORD ROAD
 BOXFORD, MA 01921

Weston & Sampson
 Weston & Sampson Engineers, Inc.
 55 Walkers Brook Drive, Suite 100
 Reading, MA 01867
 978.532.1900 800.SAMPSON
 www.westonandsampson.com

Consultants:

Revisions:

No.	Date	Description
1	10/08/21	PER PEER REVIEW
2	11/01/21	PER PEER REVIEW

Scale:

Issued For:

PERMITTING ONLY
 NOT FOR CONSTRUCTION

Scale: AS SHOWN
 Date: JULY 23, 2021
 Drawn By: CTK
 Reviewed By: JIP
 Approved By: JIP

W&S Project No.: ENG20-0865
 W&S File No.:

Drawing Title:
**POST-
 DEVELOPMENT
 PLAN
 SPOFFORD POND
 SCHOOL**

Sheet Number:
FIG.2

SPOFFORD POND WETLANDS

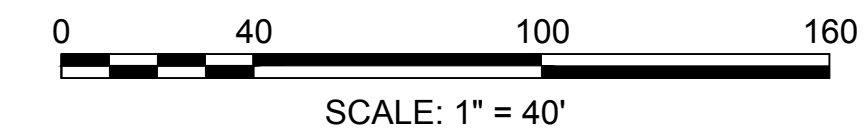

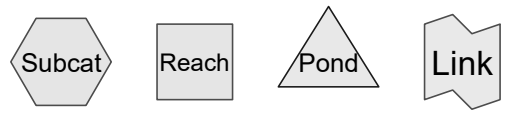
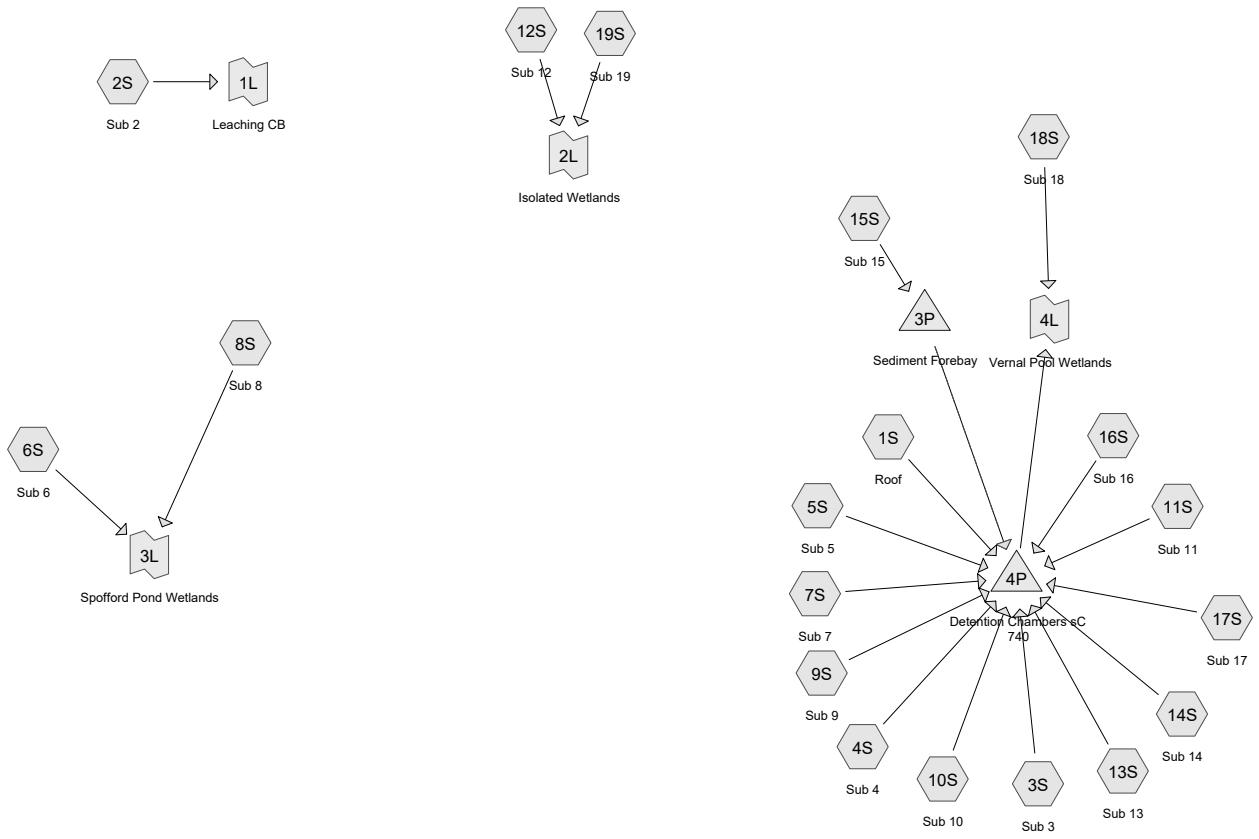

Routing Diagram for Spofford Post-Development
 Prepared by Weston & Sampson, Printed 11/5/2021
 HydroCAD® 10.10-6a s/n 00455 © 2020 HydroCAD Software Solutions LLC

Spofford Post-Development

Prepared by Weston & Sampson

HydroCAD® 10.10-6a s/n 00455 © 2020 HydroCAD Software Solutions LLC

Printed 11/5/2021

Page 2

Rainfall Events Listing

Event#	Event Name	Storm Type	Curve	Mode	Duration (hours)	B/B	Depth (inches)	AMC
1	2-year	Type III 24-hr		Default	24.00	1	3.10	2
2	10-year	Type III 24-hr		Default	24.00	1	4.70	2
3	25-year	Type III 24-hr		Default	24.00	1	5.80	2
4	50-year	Type III 24-hr		Default	24.00	1	7.10	2
5	100-year	Type III 24-hr		Default	24.00	1	8.30	2

Spofford Post-Development

Prepared by Weston & Sampson

HydroCAD® 10.10-6a s/n 00455 © 2020 HydroCAD Software Solutions LLC

Printed 11/5/2021

Page 3

Area Listing (all nodes)

Area (sq-ft)	CN	Description (subcatchment-numbers)
77,013	30	Grass (2S, 3S, 4S, 5S, 6S, 8S, 9S, 10S, 11S, 12S, 13S, 14S, 15S, 16S, 17S, 18S, 19S)
134,482	98	Paved parking, HSG A (3S, 4S, 5S, 6S, 7S, 9S, 10S, 11S, 13S, 14S, 15S, 16S, 17S, 18S)
71,161	98	Roofs, HSG A (1S)
9,104	98	Turf (impervious) (3S)
15,757	30	Woods, Good, HSG A (3S, 4S, 6S, 10S, 18S)
307,517	77	TOTAL AREA

Spofford Post-Development

Prepared by Weston & Sampson

HydroCAD® 10.10-6a s/n 00455 © 2020 HydroCAD Software Solutions LLC

Printed 11/5/2021

Page 4

Soil Listing (all nodes)

Area (sq-ft)	Soil Group	Subcatchment Numbers
221,400	HSG A	1S, 3S, 4S, 5S, 6S, 7S, 9S, 10S, 11S, 13S, 14S, 15S, 16S, 17S, 18S
0	HSG B	
0	HSG C	
0	HSG D	
86,117	Other	2S, 3S, 4S, 5S, 6S, 8S, 9S, 10S, 11S, 12S, 13S, 14S, 15S, 16S, 17S, 18S, 19S
307,517		TOTAL AREA

Spofford Post-Development

Prepared by Weston & Sampson

HydroCAD® 10.10-6a s/n 00455 © 2020 HydroCAD Software Solutions LLC

Printed 11/5/2021

Page 5

Ground Covers (all nodes)

HSG-A (sq-ft)	HSG-B (sq-ft)	HSG-C (sq-ft)	HSG-D (sq-ft)	Other (sq-ft)	Total (sq-ft)	Ground Cover	Subcatchm Numbers
0	0	0	0	77,013	77,013	Grass	
134,482	0	0	0	0	134,482	Paved parking	
71,161	0	0	0	0	71,161	Roofs	
0	0	0	0	9,104	9,104	Turf (impervious)	
15,757	0	0	0	0	15,757	Woods, Good	
221,400	0	0	0	86,117	307,517	TOTAL AREA	

Spofford Post-Development

Prepared by Weston & Sampson

HydroCAD® 10.10-6a s/n 00455 © 2020 HydroCAD Software Solutions LLC

Printed 11/5/2021

Page 6

Pipe Listing (all nodes)

Line#	Node Number	In-Invert (feet)	Out-Invert (feet)	Length (feet)	Slope (ft/ft)	n	Width (inches)	Diam/Height (inches)	Inside-Fill (inches)
1	3P	128.65	128.50	29.0	0.0052	0.013	0.0	24.0	0.0
2	4P	127.66	127.15	92.0	0.0055	0.013	0.0	24.0	0.0

Spofford Post-Development

Prepared by Weston & Sampson

HydroCAD® 10.10-6a s/n 00455 © 2020 HydroCAD Software Solutions LLC

Type III 24-hr 2-year Rainfall=3.10"

Printed 11/5/2021

Page 7

Time span=1.00-36.00 hrs, dt=0.01 hrs, 3501 points
Runoff by SCS TR-20 method, UH=SCS, Weighted-CN
Reach routing by Dyn-Stor-Ind method - Pond routing by Dyn-Stor-Ind method

Subcatchment1S: Roof	Runoff Area=71,161 sf 100.00% Impervious Runoff Depth=2.87" Tc=6.0 min CN=98 Runoff=4.91 cfs 17,007 cf
Subcatchment2S: Sub 2	Runoff Area=9,774 sf 0.00% Impervious Runoff Depth=0.00" Tc=6.0 min CN=30 Runoff=0.00 cfs 0 cf
Subcatchment3S: Sub 3	Runoff Area=24,730 sf 73.09% Impervious Runoff Depth=1.33" Tc=6.0 min CN=80 Runoff=0.87 cfs 2,732 cf
Subcatchment4S: Sub 4	Runoff Area=13,951 sf 62.30% Impervious Runoff Depth=0.87" Tc=6.0 min CN=72 Runoff=0.30 cfs 1,009 cf
Subcatchment5S: Sub 5	Runoff Area=10,142 sf 79.94% Impervious Runoff Depth=1.60" Tc=6.0 min CN=84 Runoff=0.44 cfs 1,351 cf
Subcatchment6S: Sub 6	Runoff Area=18,754 sf 13.86% Impervious Runoff Depth=0.00" Tc=6.0 min CN=39 Runoff=0.00 cfs 0 cf
Subcatchment7S: Sub 7	Runoff Area=4,674 sf 100.00% Impervious Runoff Depth=2.87" Tc=6.0 min CN=98 Runoff=0.32 cfs 1,117 cf
Subcatchment8S: Sub 8	Runoff Area=23,822 sf 0.00% Impervious Runoff Depth=0.00" Tc=6.0 min CN=30 Runoff=0.00 cfs 0 cf
Subcatchment9S: Sub 9	Runoff Area=9,379 sf 95.68% Impervious Runoff Depth=2.55" Tc=6.0 min CN=95 Runoff=0.61 cfs 1,991 cf
Subcatchment10S: Sub 10	Runoff Area=18,532 sf 69.05% Impervious Runoff Depth=1.14" Tc=6.0 min CN=77 Runoff=0.55 cfs 1,762 cf
Subcatchment11S: Sub 11	Runoff Area=6,808 sf 98.43% Impervious Runoff Depth=2.76" Tc=6.0 min CN=97 Runoff=0.46 cfs 1,564 cf
Subcatchment12S: Sub 12	Runoff Area=5,470 sf 0.00% Impervious Runoff Depth=0.00" Tc=6.0 min CN=30 Runoff=0.00 cfs 0 cf
Subcatchment13S: Sub 13	Runoff Area=3,318 sf 87.70% Impervious Runoff Depth=2.08" Tc=6.0 min CN=90 Runoff=0.18 cfs 574 cf
Subcatchment14S: Sub 14	Runoff Area=3,898 sf 96.02% Impervious Runoff Depth=2.55" Tc=6.0 min CN=95 Runoff=0.25 cfs 827 cf
Subcatchment15S: Sub 15	Runoff Area=46,388 sf 96.62% Impervious Runoff Depth=2.65" Tc=6.0 min CN=96 Runoff=3.09 cfs 10,246 cf
Subcatchment16S: Sub 16	Runoff Area=11,222 sf 92.68% Impervious Runoff Depth=2.35" Tc=6.0 min CN=93 Runoff=0.69 cfs 2,197 cf

Spofford Post-Development

Prepared by Weston & Sampson

HydroCAD® 10.10-6a s/n 00455 © 2020 HydroCAD Software Solutions LLC

Type III 24-hr 2-year Rainfall=3.10"

Printed 11/5/2021

Page 8

Subcatchment 17S: Sub 17	Runoff Area=10,851 sf 98.57% Impervious Runoff Depth=2.76" Tc=6.0 min CN=97 Runoff=0.74 cfs 2,493 cf
Subcatchment 18S: Sub 18	Runoff Area=10,690 sf 3.71% Impervious Runoff Depth=0.00" Tc=6.0 min CN=33 Runoff=0.00 cfs 0 cf
Subcatchment 19S: Sub 19	Runoff Area=3,953 sf 0.00% Impervious Runoff Depth=0.00" Tc=6.0 min CN=30 Runoff=0.00 cfs 0 cf
Pond 3P: Sediment Forebay	Peak Elev=133.74' Storage=661 cf Inflow=3.09 cfs 10,246 cf Primary=3.01 cfs 9,872 cf Secondary=0.00 cfs 0 cf Outflow=3.01 cfs 9,872 cf
Pond 4P: Detention Chambers sC 740	Peak Elev=129.10' Storage=12,639 cf Inflow=13.27 cfs 44,498 cf Outflow=7.49 cfs 44,195 cf
Link 1L: Leaching CB	Inflow=0.00 cfs 0 cf Primary=0.00 cfs 0 cf
Link 2L: Isolated Wetlands	Inflow=0.00 cfs 0 cf Primary=0.00 cfs 0 cf
Link 3L: Spofford Pond Wetlands	Inflow=0.00 cfs 0 cf Primary=0.00 cfs 0 cf
Link 4L: Vernal Pool Wetlands	Inflow=7.49 cfs 44,195 cf Primary=7.49 cfs 44,195 cf

Total Runoff Area = 307,517 sf Runoff Volume = 44,872 cf Average Runoff Depth = 1.75"
30.17% Pervious = 92,770 sf 69.83% Impervious = 214,747 sf

Spofford Post-Development

Prepared by Weston & Sampson

HydroCAD® 10.10-6a s/n 00455 © 2020 HydroCAD Software Solutions LLC

Type III 24-hr 2-year Rainfall=3.10"

Printed 11/5/2021

Page 9

Summary for Subcatchment 1S: Roof

Runoff = 4.91 cfs @ 12.08 hrs, Volume= 17,007 cf, Depth= 2.87"
Routed to Pond 4P : Detention Chambers sC 740

Runoff by SCS TR-20 method, UH=SCS, Weighted-CN, Time Span= 1.00-36.00 hrs, dt= 0.01 hrs
Type III 24-hr 2-year Rainfall=3.10"

Area (sf)	CN	Description
71,161	98	Roofs, HSG A
71,161		100.00% Impervious Area

Tc (min)	Length (feet)	Slope (ft/ft)	Velocity (ft/sec)	Capacity (cfs)	Description
6.0					Direct Entry,

Subcatchment 1S: Roof

Hydrograph

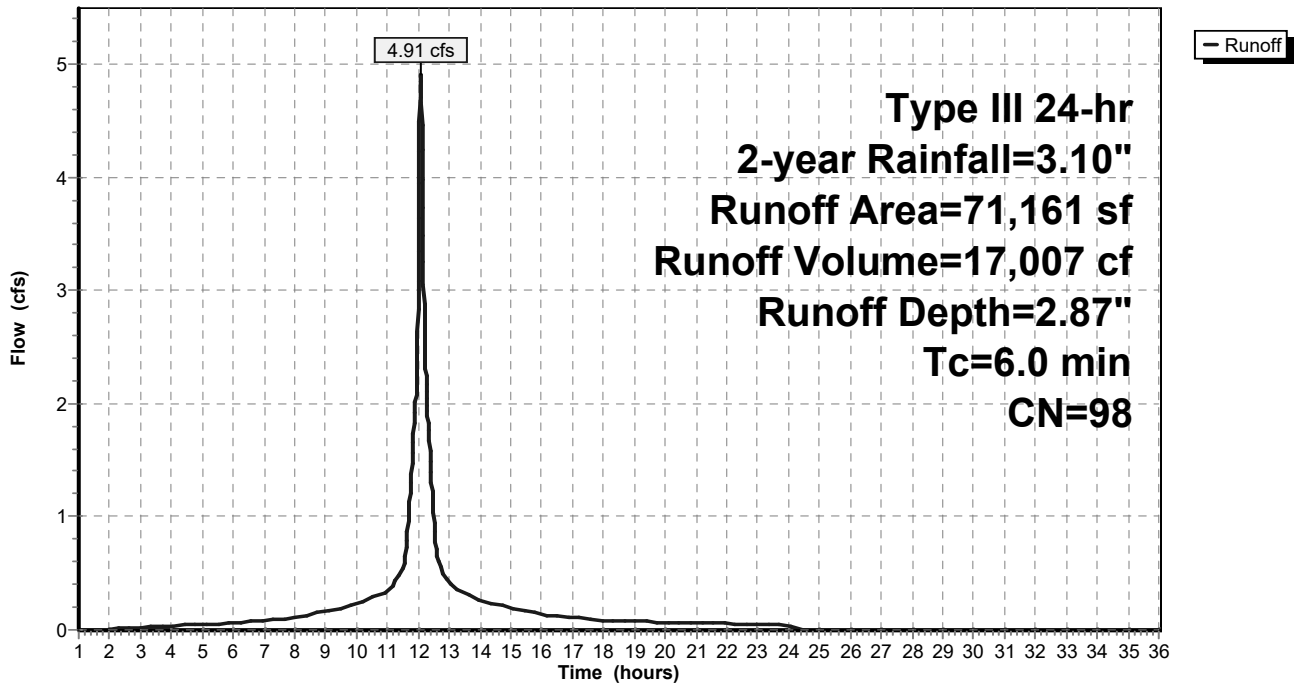

Spofford Post-Development

Prepared by Weston & Sampson

HydroCAD® 10.10-6a s/n 00455 © 2020 HydroCAD Software Solutions LLC

Type III 24-hr 2-year Rainfall=3.10"

Printed 11/5/2021

Page 10

Summary for Subcatchment 2S: Sub 2

Runoff = 0.00 cfs @ 1.00 hrs, Volume= 0 cf, Depth= 0.00"

Routed to Link 1L : Leaching CB

Runoff by SCS TR-20 method, UH=SCS, Weighted-CN, Time Span= 1.00-36.00 hrs, dt= 0.01 hrs
 Type III 24-hr 2-year Rainfall=3.10"

Area (sf)	CN	Description
* 9,774	30	Grass
9,774		100.00% Pervious Area

Tc (min)	Length (feet)	Slope (ft/ft)	Velocity (ft/sec)	Capacity (cfs)	Description
6.0					Direct Entry,

Subcatchment 2S: Sub 2

Hydrograph

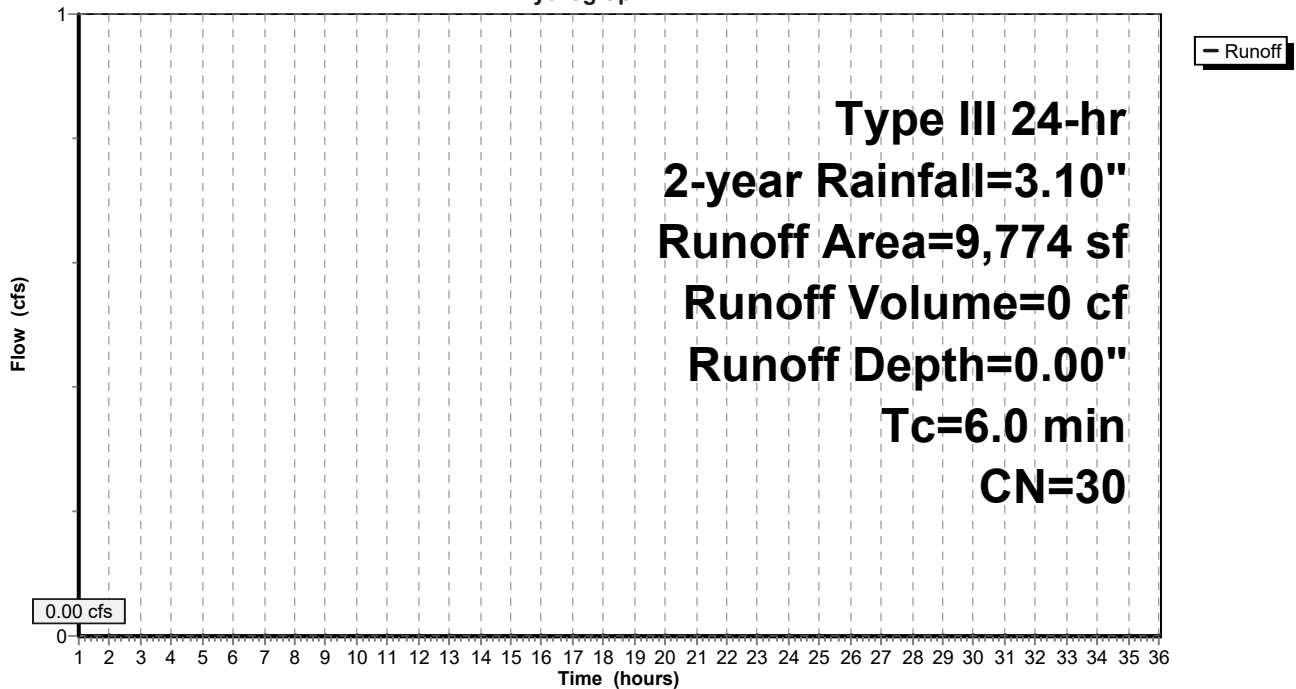

Spofford Post-Development

Prepared by Weston & Sampson

HydroCAD® 10.10-6a s/n 00455 © 2020 HydroCAD Software Solutions LLC

Type III 24-hr 2-year Rainfall=3.10"

Printed 11/5/2021

Page 11

Summary for Subcatchment 3S: Sub 3

Runoff = 0.87 cfs @ 12.09 hrs, Volume= 2,732 cf, Depth= 1.33"
Routed to Pond 4P : Detention Chambers sC 740

Runoff by SCS TR-20 method, UH=SCS, Weighted-CN, Time Span= 1.00-36.00 hrs, dt= 0.01 hrs
Type III 24-hr 2-year Rainfall=3.10"

	Area (sf)	CN	Description
	8,972	98	Paved parking, HSG A
*	9,104	98	Turf (impervious)
*	5,760	30	Grass
	894	30	Woods, Good, HSG A
	24,730	80	Weighted Average
	6,654		26.91% Pervious Area
	18,076		73.09% Impervious Area

Tc (min)	Length (feet)	Slope (ft/ft)	Velocity (ft/sec)	Capacity (cfs)	Description
6.0					Direct Entry,

Subcatchment 3S: Sub 3

Hydrograph

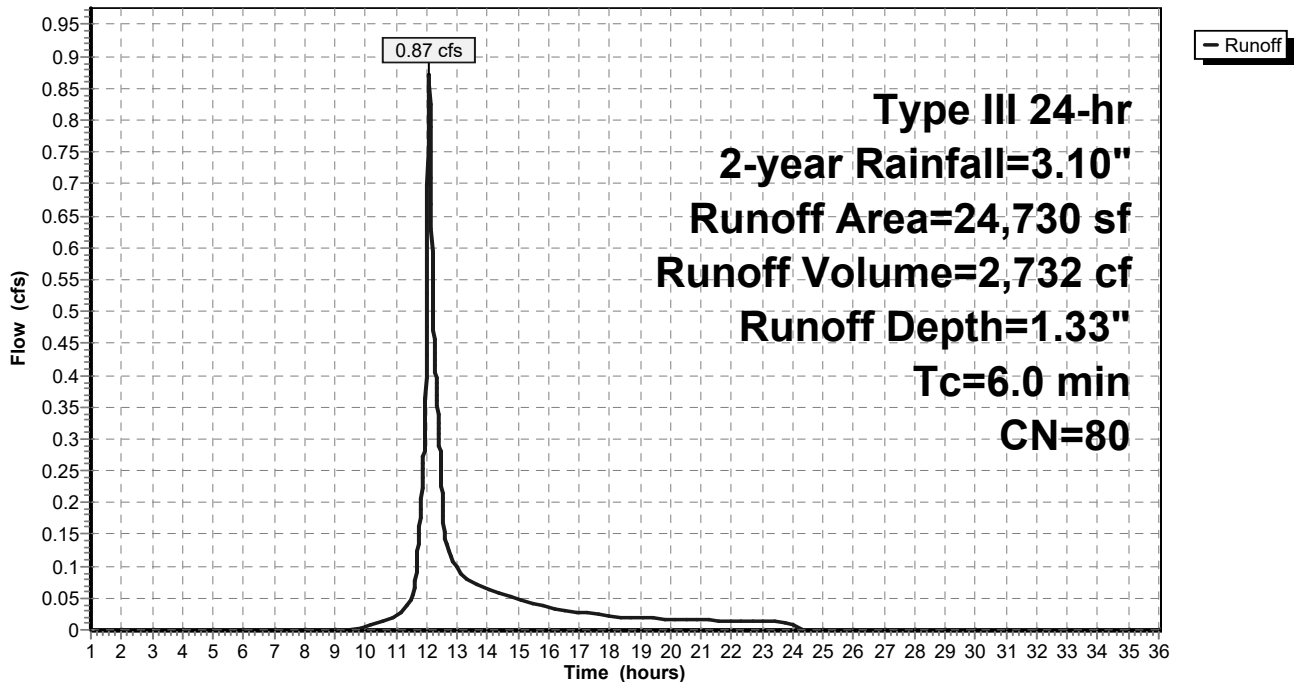

Spofford Post-Development

Prepared by Weston & Sampson

HydroCAD® 10.10-6a s/n 00455 © 2020 HydroCAD Software Solutions LLC

Type III 24-hr 2-year Rainfall=3.10"

Printed 11/5/2021

Page 12

Summary for Subcatchment 4S: Sub 4

Runoff = 0.30 cfs @ 12.10 hrs, Volume= 1,009 cf, Depth= 0.87"
 Routed to Pond 4P : Detention Chambers sC 740

Runoff by SCS TR-20 method, UH=SCS, Weighted-CN, Time Span= 1.00-36.00 hrs, dt= 0.01 hrs
 Type III 24-hr 2-year Rainfall=3.10"

Area (sf)	CN	Description
8,691	98	Paved parking, HSG A
2,060	30	Woods, Good, HSG A
* 3,200	30	Grass
13,951	72	Weighted Average
5,260		37.70% Pervious Area
8,691		62.30% Impervious Area

Tc (min)	Length (feet)	Slope (ft/ft)	Velocity (ft/sec)	Capacity (cfs)	Description
6.0					Direct Entry,

Subcatchment 4S: Sub 4

Hydrograph

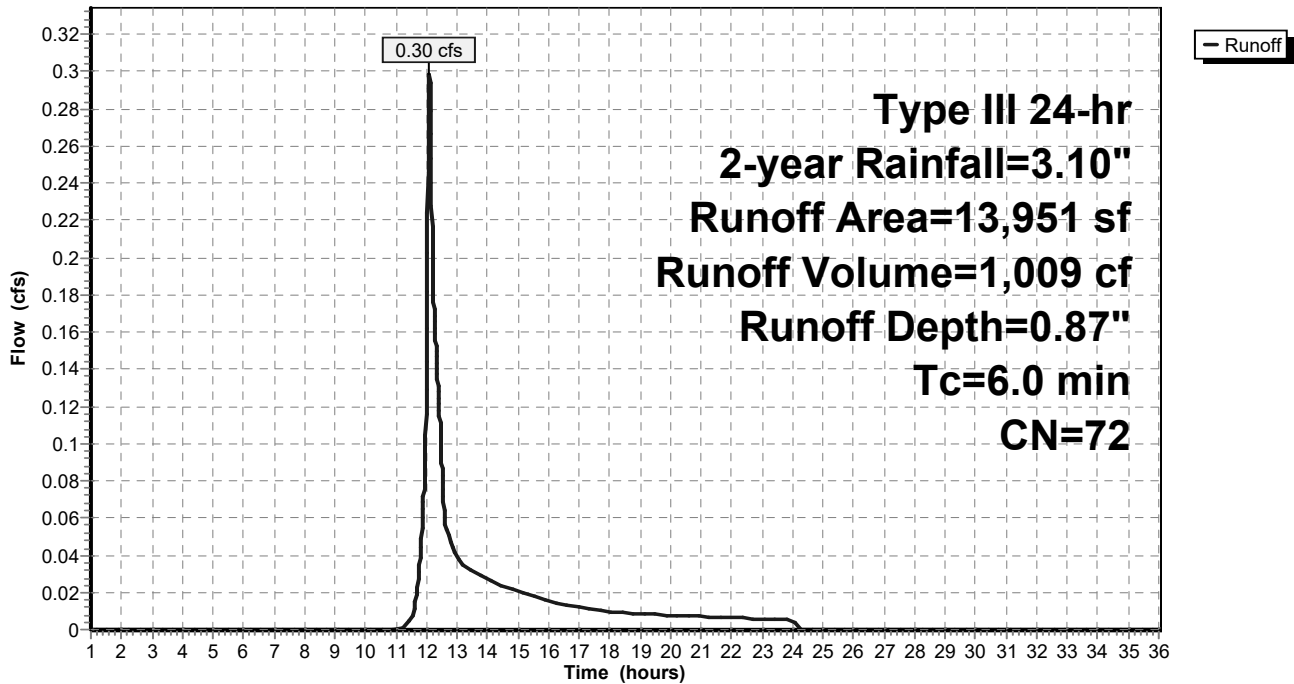

Spofford Post-Development

Prepared by Weston & Sampson

HydroCAD® 10.10-6a s/n 00455 © 2020 HydroCAD Software Solutions LLC

Type III 24-hr 2-year Rainfall=3.10"

Printed 11/5/2021

Page 13

Summary for Subcatchment 5S: Sub 5

Runoff = 0.44 cfs @ 12.09 hrs, Volume= 1,351 cf, Depth= 1.60"
Routed to Pond 4P : Detention Chambers sC 740

Runoff by SCS TR-20 method, UH=SCS, Weighted-CN, Time Span= 1.00-36.00 hrs, dt= 0.01 hrs
Type III 24-hr 2-year Rainfall=3.10"

Area (sf)	CN	Description
8,108	98	Paved parking, HSG A
* 2,034	30	Grass
10,142	84	Weighted Average
2,034		20.06% Pervious Area
8,108		79.94% Impervious Area

Tc (min)	Length (feet)	Slope (ft/ft)	Velocity (ft/sec)	Capacity (cfs)	Description
6.0					Direct Entry,

Subcatchment 5S: Sub 5

Hydrograph

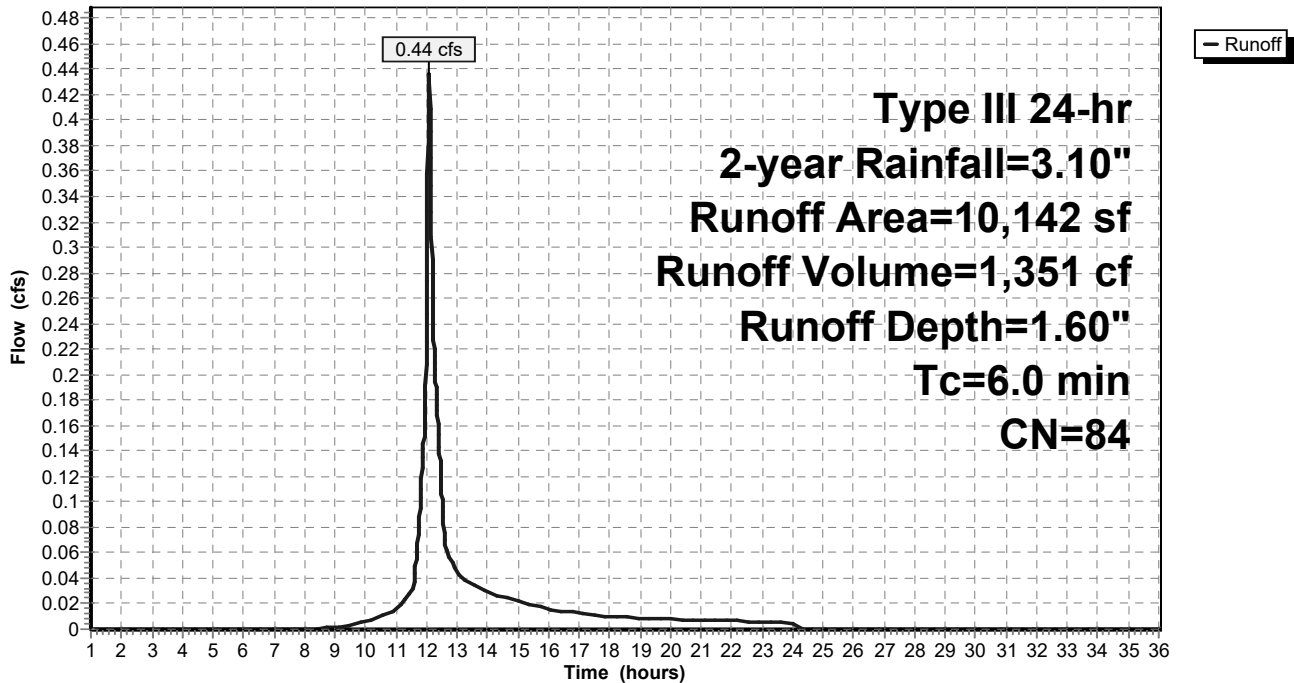

Spofford Post-Development

Prepared by Weston & Sampson

HydroCAD® 10.10-6a s/n 00455 © 2020 HydroCAD Software Solutions LLC

Type III 24-hr 2-year Rainfall=3.10"

Printed 11/5/2021

Page 14

Summary for Subcatchment 6S: Sub 6

Runoff = 0.00 cfs @ 1.00 hrs, Volume= 0 cf, Depth= 0.00"

Routed to Link 3L : Spofford Pond Wetlands

Runoff by SCS TR-20 method, UH=SCS, Weighted-CN, Time Span= 1.00-36.00 hrs, dt= 0.01 hrs
 Type III 24-hr 2-year Rainfall=3.10"

	Area (sf)	CN	Description
*	8,202	30	Grass
	7,952	30	Woods, Good, HSG A
	2,600	98	Paved parking, HSG A
	18,754	39	Weighted Average
	16,154		86.14% Pervious Area
	2,600		13.86% Impervious Area

Tc (min)	Length (feet)	Slope (ft/ft)	Velocity (ft/sec)	Capacity (cfs)	Description
6.0					Direct Entry,

Subcatchment 6S: Sub 6

Hydrograph

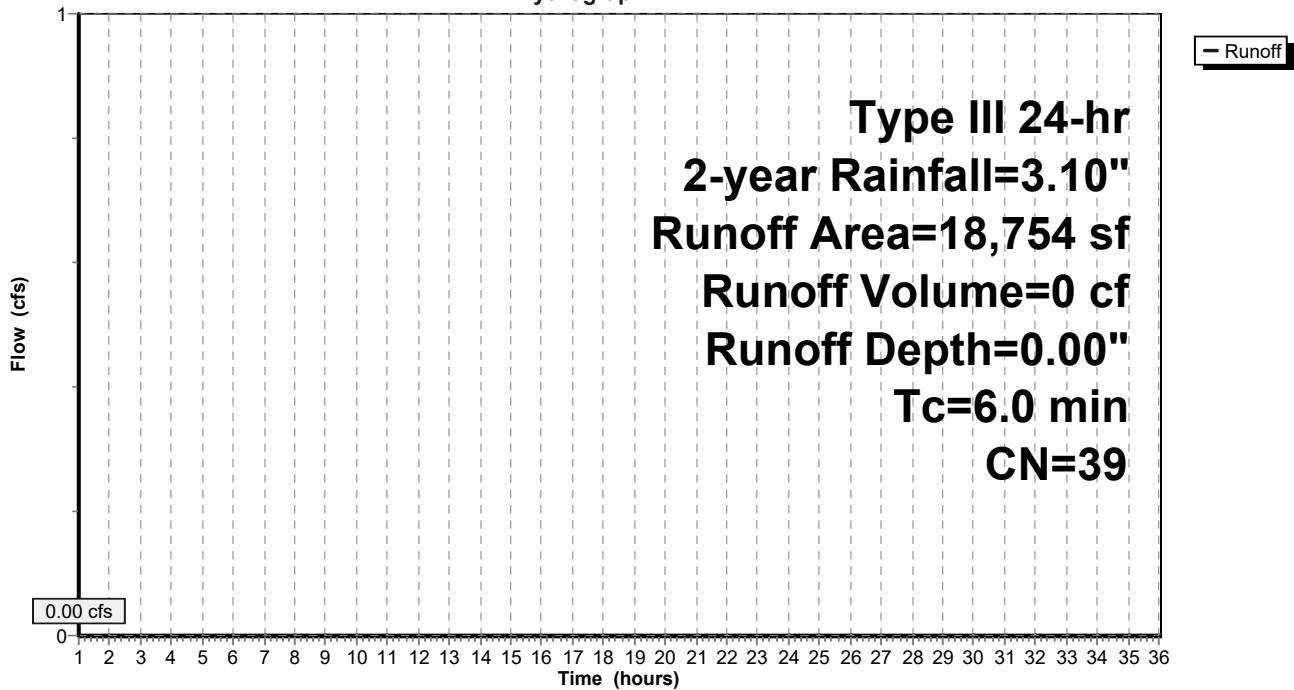

Spofford Post-Development

Prepared by Weston & Sampson

HydroCAD® 10.10-6a s/n 00455 © 2020 HydroCAD Software Solutions LLC

Type III 24-hr 2-year Rainfall=3.10"

Printed 11/5/2021

Page 15

Summary for Subcatchment 7S: Sub 7

Runoff = 0.32 cfs @ 12.08 hrs, Volume= 1,117 cf, Depth= 2.87"
Routed to Pond 4P : Detention Chambers sC 740

Runoff by SCS TR-20 method, UH=SCS, Weighted-CN, Time Span= 1.00-36.00 hrs, dt= 0.01 hrs
Type III 24-hr 2-year Rainfall=3.10"

Area (sf)	CN	Description
4,674	98	Paved parking, HSG A
4,674		100.00% Impervious Area

Tc (min)	Length (feet)	Slope (ft/ft)	Velocity (ft/sec)	Capacity (cfs)	Description
6.0					Direct Entry,

Subcatchment 7S: Sub 7

Hydrograph

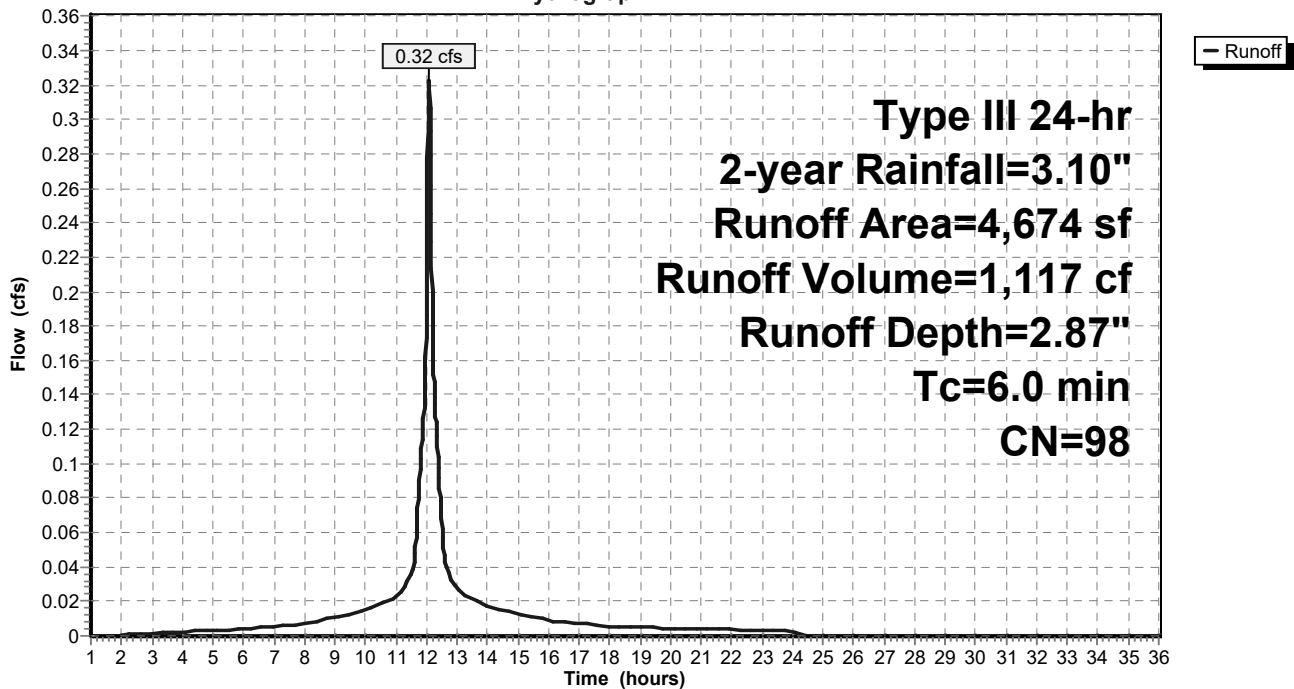

Spofford Post-Development

Prepared by Weston & Sampson

HydroCAD® 10.10-6a s/n 00455 © 2020 HydroCAD Software Solutions LLC

Type III 24-hr 2-year Rainfall=3.10"

Printed 11/5/2021

Page 16

Summary for Subcatchment 8S: Sub 8

Runoff = 0.00 cfs @ 1.00 hrs, Volume= 0 cf, Depth= 0.00"

Routed to Link 3L : Spofford Pond Wetlands

Runoff by SCS TR-20 method, UH=SCS, Weighted-CN, Time Span= 1.00-36.00 hrs, dt= 0.01 hrs
Type III 24-hr 2-year Rainfall=3.10"

Area (sf)	CN	Description
* 23,822	30	Grass
23,822		100.00% Pervious Area

Tc (min)	Length (feet)	Slope (ft/ft)	Velocity (ft/sec)	Capacity (cfs)	Description
6.0					Direct Entry,

Subcatchment 8S: Sub 8

Hydrograph

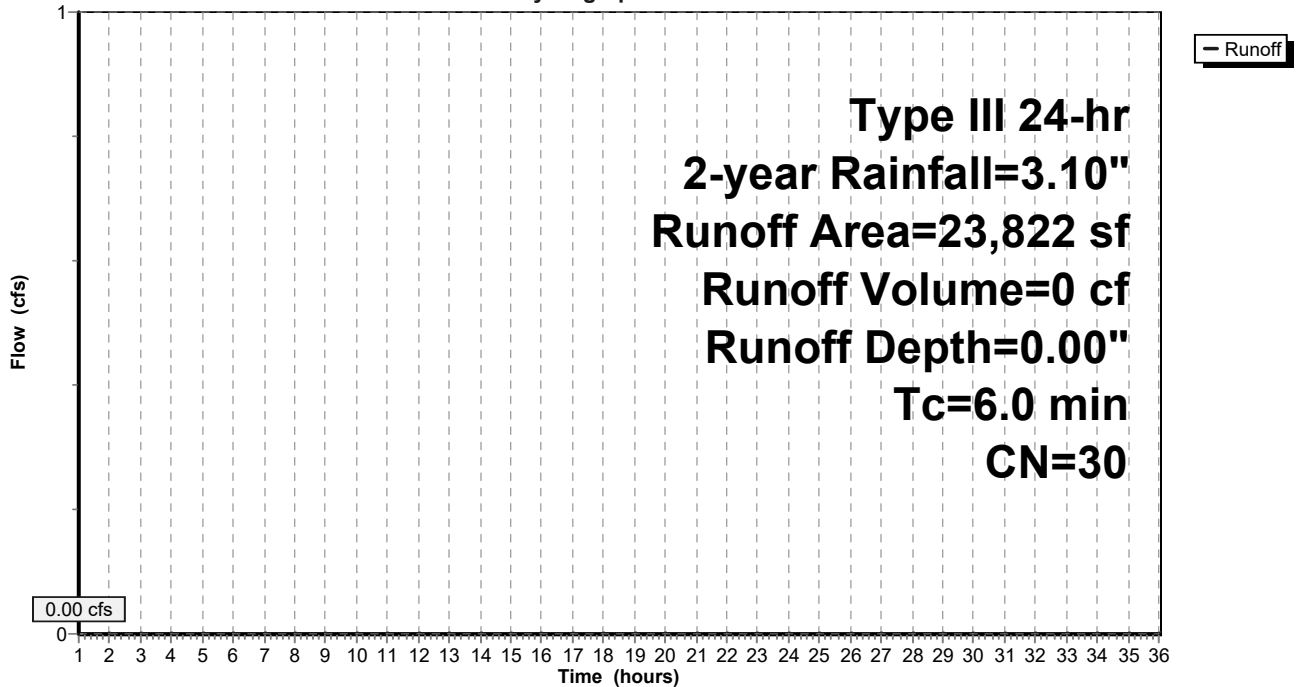

Spofford Post-Development

Prepared by Weston & Sampson

HydroCAD® 10.10-6a s/n 00455 © 2020 HydroCAD Software Solutions LLC

Type III 24-hr 2-year Rainfall=3.10"

Printed 11/5/2021

Page 17

Summary for Subcatchment 9S: Sub 9

Runoff = 0.61 cfs @ 12.08 hrs, Volume= 1,991 cf, Depth= 2.55"
 Routed to Pond 4P : Detention Chambers sC 740

Runoff by SCS TR-20 method, UH=SCS, Weighted-CN, Time Span= 1.00-36.00 hrs, dt= 0.01 hrs
 Type III 24-hr 2-year Rainfall=3.10"

Area (sf)	CN	Description
8,974	98	Paved parking, HSG A
* 405	30	Grass
9,379	95	Weighted Average
405		4.32% Pervious Area
8,974		95.68% Impervious Area

Tc (min)	Length (feet)	Slope (ft/ft)	Velocity (ft/sec)	Capacity (cfs)	Description
6.0					Direct Entry,

Subcatchment 9S: Sub 9

Hydrograph

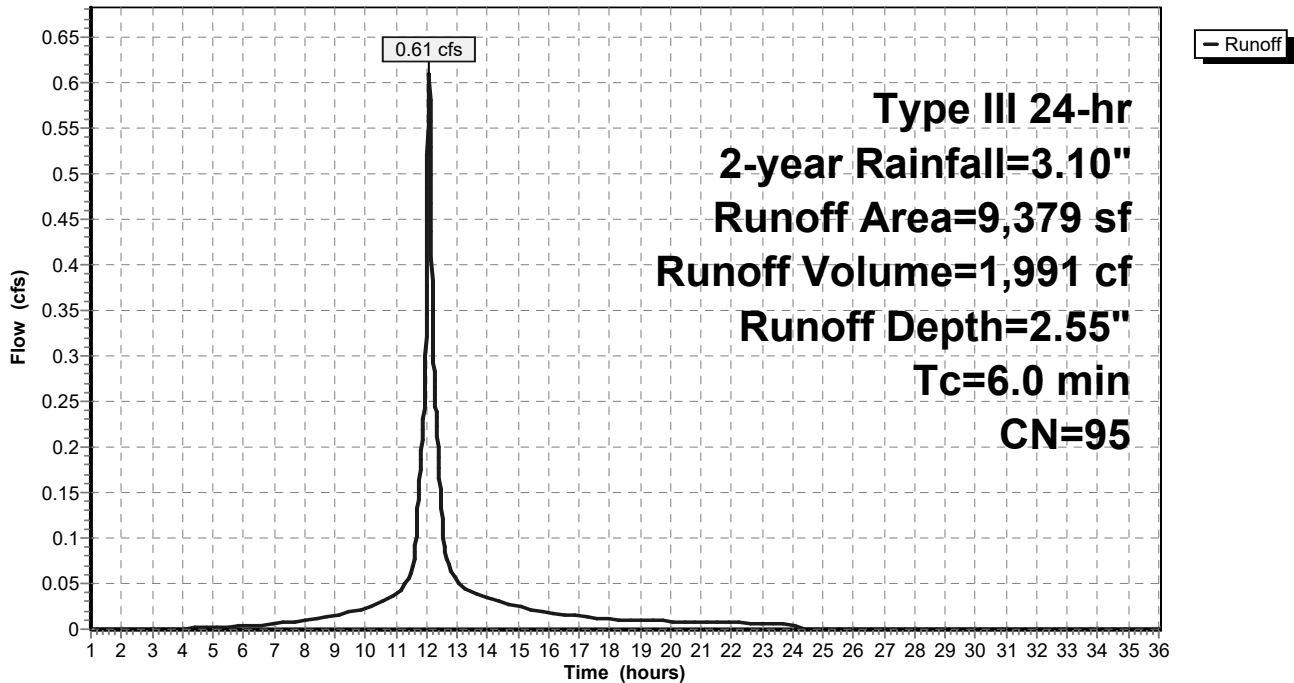

Spofford Post-Development

Prepared by Weston & Sampson

HydroCAD® 10.10-6a s/n 00455 © 2020 HydroCAD Software Solutions LLC

Type III 24-hr 2-year Rainfall=3.10"

Printed 11/5/2021

Page 18

Summary for Subcatchment 10S: Sub 10

Runoff = 0.55 cfs @ 12.09 hrs, Volume= 1,762 cf, Depth= 1.14"
Routed to Pond 4P : Detention Chambers sC 740

Runoff by SCS TR-20 method, UH=SCS, Weighted-CN, Time Span= 1.00-36.00 hrs, dt= 0.01 hrs
Type III 24-hr 2-year Rainfall=3.10"

Area (sf)	CN	Description
12,796	98	Paved parking, HSG A
424	30	Woods, Good, HSG A
* 5,312	30	Grass
18,532	77	Weighted Average
5,736		30.95% Pervious Area
12,796		69.05% Impervious Area

Tc (min)	Length (feet)	Slope (ft/ft)	Velocity (ft/sec)	Capacity (cfs)	Description
6.0					Direct Entry,

Subcatchment 10S: Sub 10

Hydrograph

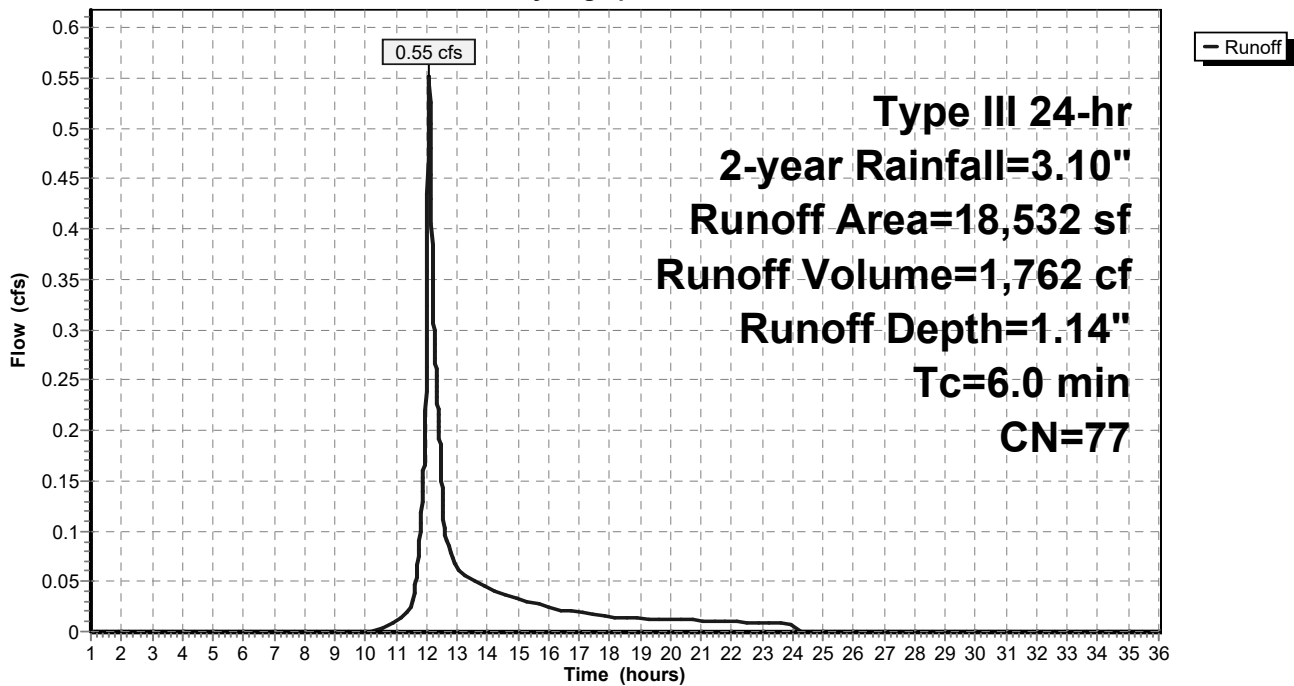

Spofford Post-Development

Prepared by Weston & Sampson

HydroCAD® 10.10-6a s/n 00455 © 2020 HydroCAD Software Solutions LLC

Type III 24-hr 2-year Rainfall=3.10"

Printed 11/5/2021

Page 19

Summary for Subcatchment 11S: Sub 11

Runoff = 0.46 cfs @ 12.08 hrs, Volume= 1,564 cf, Depth= 2.76"
 Routed to Pond 4P : Detention Chambers sC 740

Runoff by SCS TR-20 method, UH=SCS, Weighted-CN, Time Span= 1.00-36.00 hrs, dt= 0.01 hrs
 Type III 24-hr 2-year Rainfall=3.10"

Area (sf)	CN	Description
6,701	98	Paved parking, HSG A
* 107	30	Grass
6,808	97	Weighted Average
107		1.57% Pervious Area
6,701		98.43% Impervious Area

Tc (min)	Length (feet)	Slope (ft/ft)	Velocity (ft/sec)	Capacity (cfs)	Description
6.0					Direct Entry,

Subcatchment 11S: Sub 11

Hydrograph

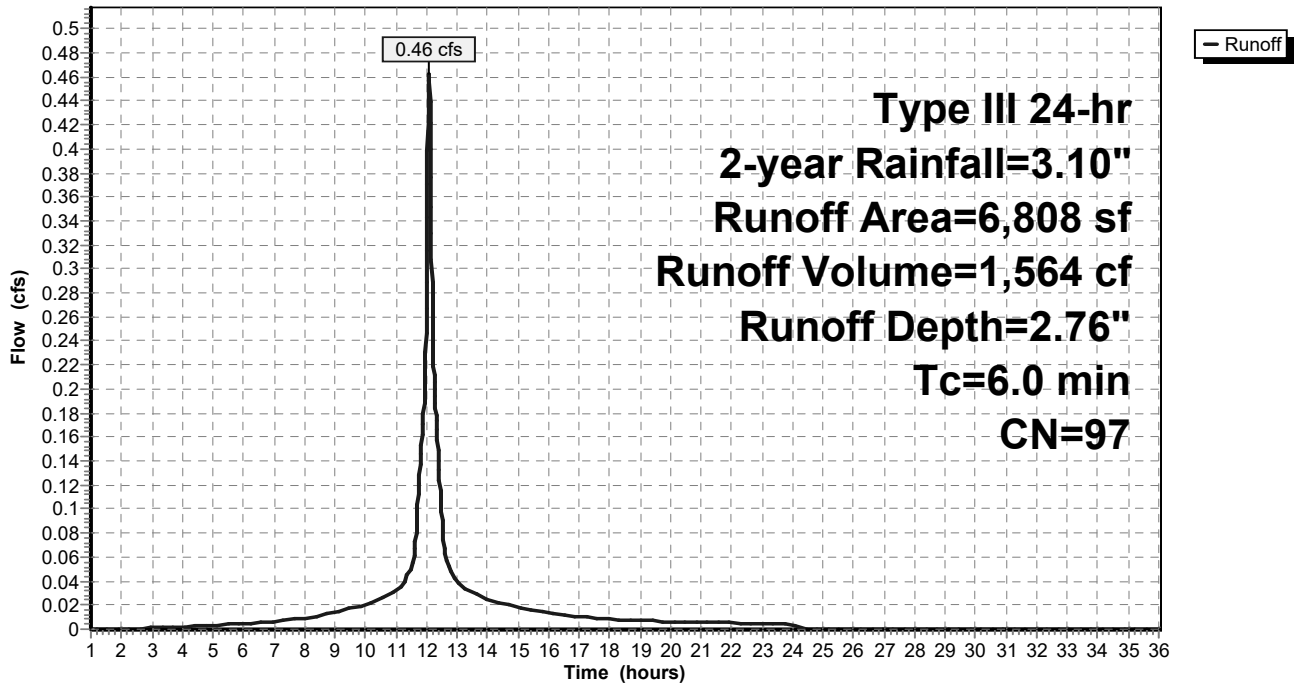

Spofford Post-Development

Prepared by Weston & Sampson

HydroCAD® 10.10-6a s/n 00455 © 2020 HydroCAD Software Solutions LLC

Type III 24-hr 2-year Rainfall=3.10"

Printed 11/5/2021

Page 20

Summary for Subcatchment 12S: Sub 12

Runoff = 0.00 cfs @ 1.00 hrs, Volume= 0 cf, Depth= 0.00"
Routed to Link 2L : Isolated Wetlands

Runoff by SCS TR-20 method, UH=SCS, Weighted-CN, Time Span= 1.00-36.00 hrs, dt= 0.01 hrs
Type III 24-hr 2-year Rainfall=3.10"

	Area (sf)	CN	Description
*	5,470	30	Grass
	5,470		100.00% Pervious Area

Tc (min)	Length (feet)	Slope (ft/ft)	Velocity (ft/sec)	Capacity (cfs)	Description
6.0					Direct Entry,

Subcatchment 12S: Sub 12

Hydrograph

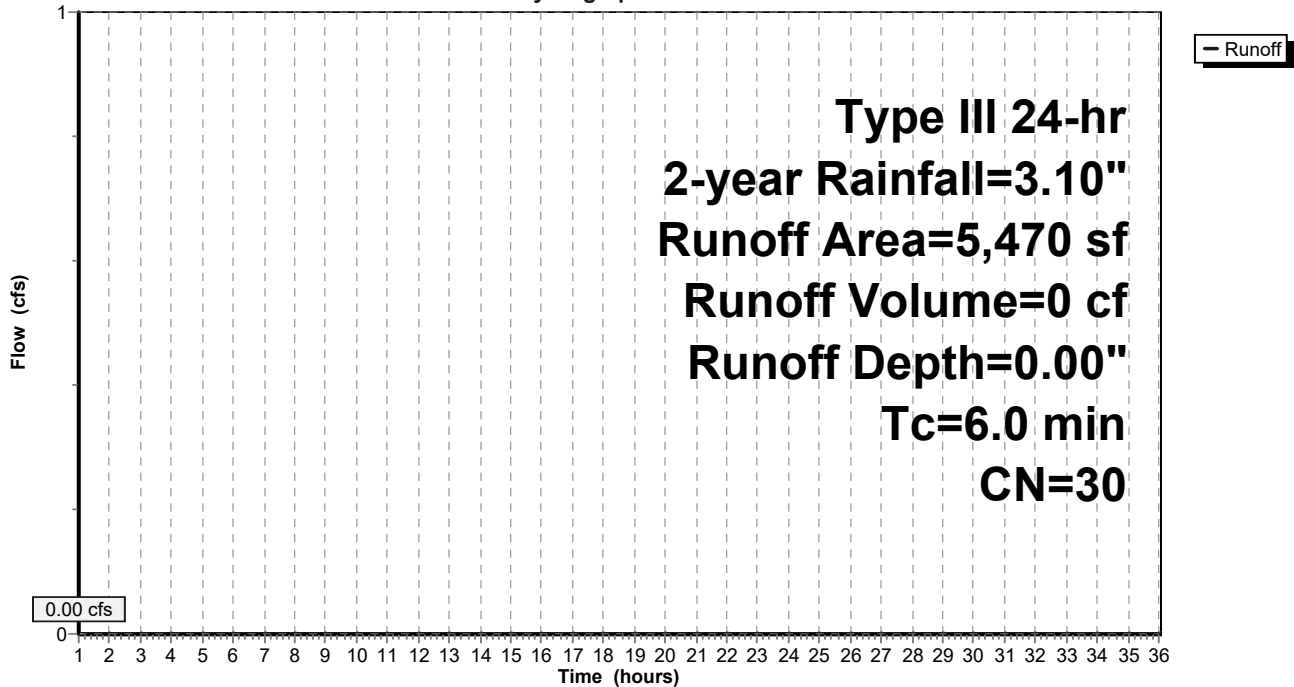

Spofford Post-Development

Prepared by Weston & Sampson

HydroCAD® 10.10-6a s/n 00455 © 2020 HydroCAD Software Solutions LLC

Type III 24-hr 2-year Rainfall=3.10"

Printed 11/5/2021

Page 21

Summary for Subcatchment 13S: Sub 13

Runoff = 0.18 cfs @ 12.09 hrs, Volume= 574 cf, Depth= 2.08"
Routed to Pond 4P : Detention Chambers sC 740

Runoff by SCS TR-20 method, UH=SCS, Weighted-CN, Time Span= 1.00-36.00 hrs, dt= 0.01 hrs
Type III 24-hr 2-year Rainfall=3.10"

Area (sf)	CN	Description
2,910	98	Paved parking, HSG A
* 408	30	Grass
3,318	90	Weighted Average
408		12.30% Pervious Area
2,910		87.70% Impervious Area

Tc (min)	Length (feet)	Slope (ft/ft)	Velocity (ft/sec)	Capacity (cfs)	Description
6.0					Direct Entry,

Subcatchment 13S: Sub 13

Hydrograph

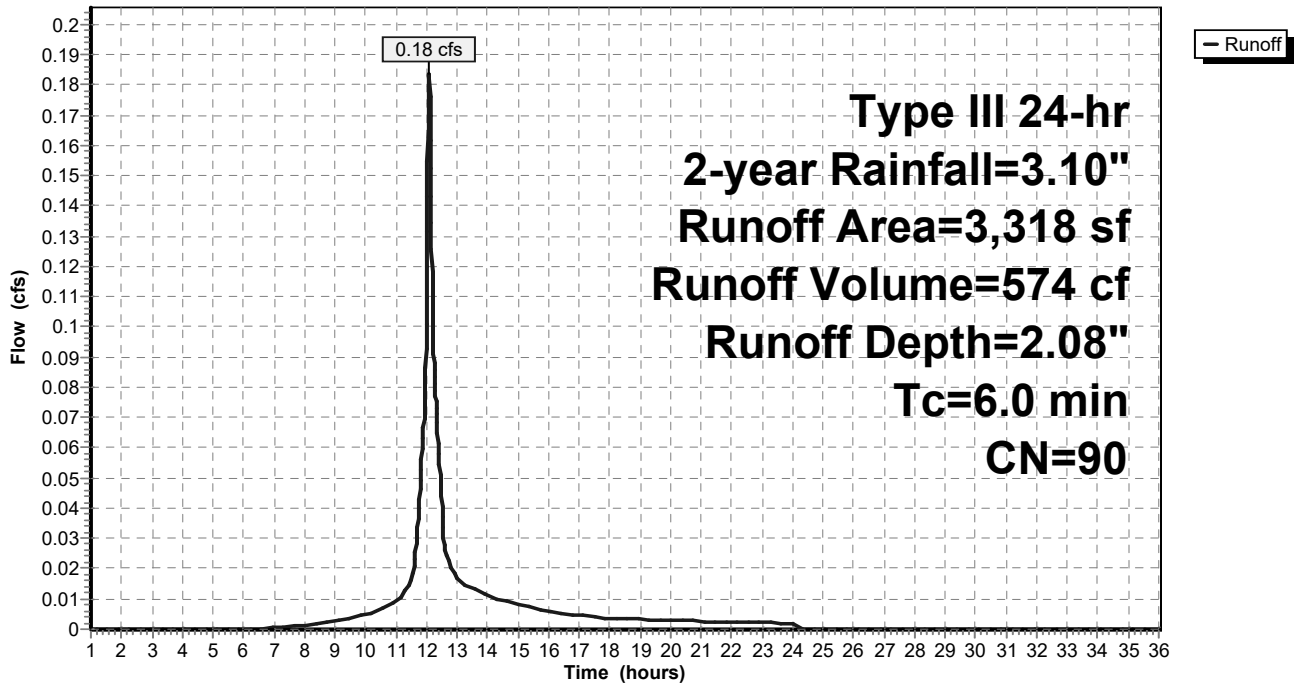

Spofford Post-Development

Prepared by Weston & Sampson

HydroCAD® 10.10-6a s/n 00455 © 2020 HydroCAD Software Solutions LLC

Type III 24-hr 2-year Rainfall=3.10"

Printed 11/5/2021

Page 22

Summary for Subcatchment 14S: Sub 14

Runoff = 0.25 cfs @ 12.08 hrs, Volume= 827 cf, Depth= 2.55"
 Routed to Pond 4P : Detention Chambers sC 740

Runoff by SCS TR-20 method, UH=SCS, Weighted-CN, Time Span= 1.00-36.00 hrs, dt= 0.01 hrs
 Type III 24-hr 2-year Rainfall=3.10"

Area (sf)	CN	Description
3,743	98	Paved parking, HSG A
* 155	30	Grass
3,898	95	Weighted Average
155		3.98% Pervious Area
3,743		96.02% Impervious Area

Tc (min)	Length (feet)	Slope (ft/ft)	Velocity (ft/sec)	Capacity (cfs)	Description
6.0					Direct Entry,

Subcatchment 14S: Sub 14

Hydrograph

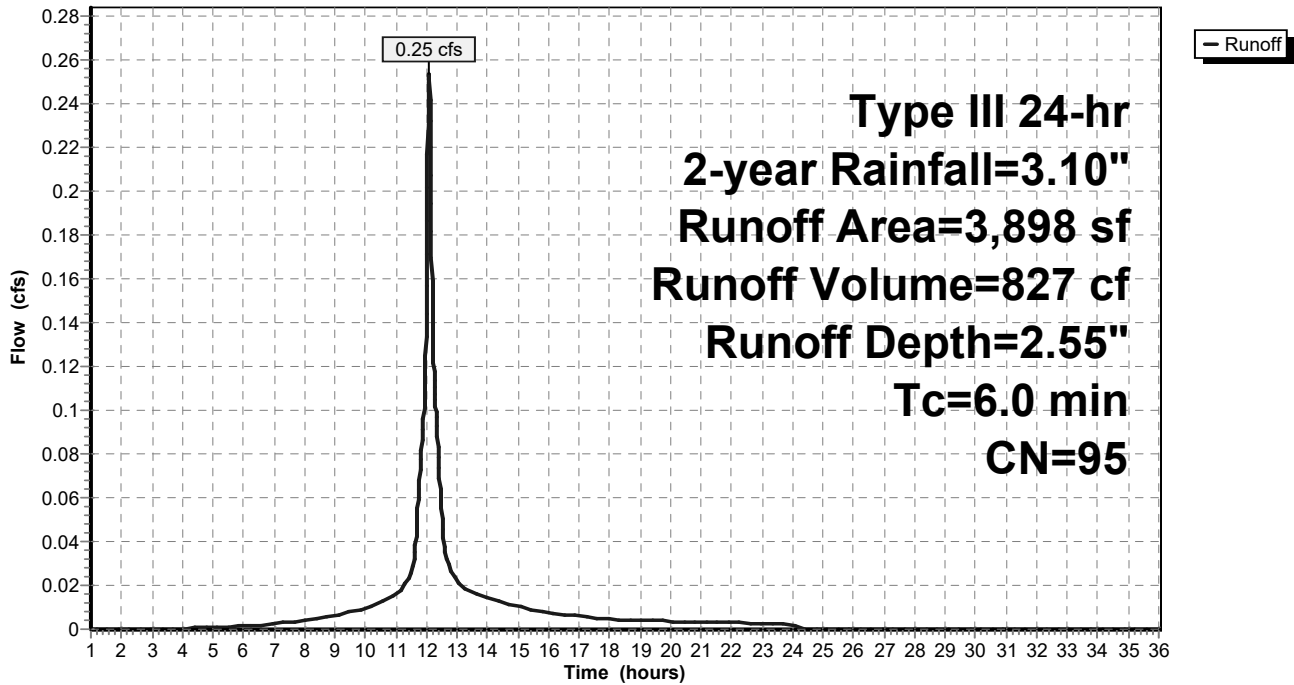

Spofford Post-Development

Prepared by Weston & Sampson

HydroCAD® 10.10-6a s/n 00455 © 2020 HydroCAD Software Solutions LLC

Type III 24-hr 2-year Rainfall=3.10"

Printed 11/5/2021

Page 23

Summary for Subcatchment 15S: Sub 15

Runoff = 3.09 cfs @ 12.08 hrs, Volume= 10,246 cf, Depth= 2.65"

Routed to Pond 3P : Sediment Forebay

Runoff by SCS TR-20 method, UH=SCS, Weighted-CN, Time Span= 1.00-36.00 hrs, dt= 0.01 hrs
Type III 24-hr 2-year Rainfall=3.10"

	Area (sf)	CN	Description
*	1,568	30	Grass
	44,820	98	Paved parking, HSG A
	46,388	96	Weighted Average
	1,568		3.38% Pervious Area
	44,820		96.62% Impervious Area

Tc (min)	Length (feet)	Slope (ft/ft)	Velocity (ft/sec)	Capacity (cfs)	Description
6.0					Direct Entry,

Subcatchment 15S: Sub 15

Hydrograph

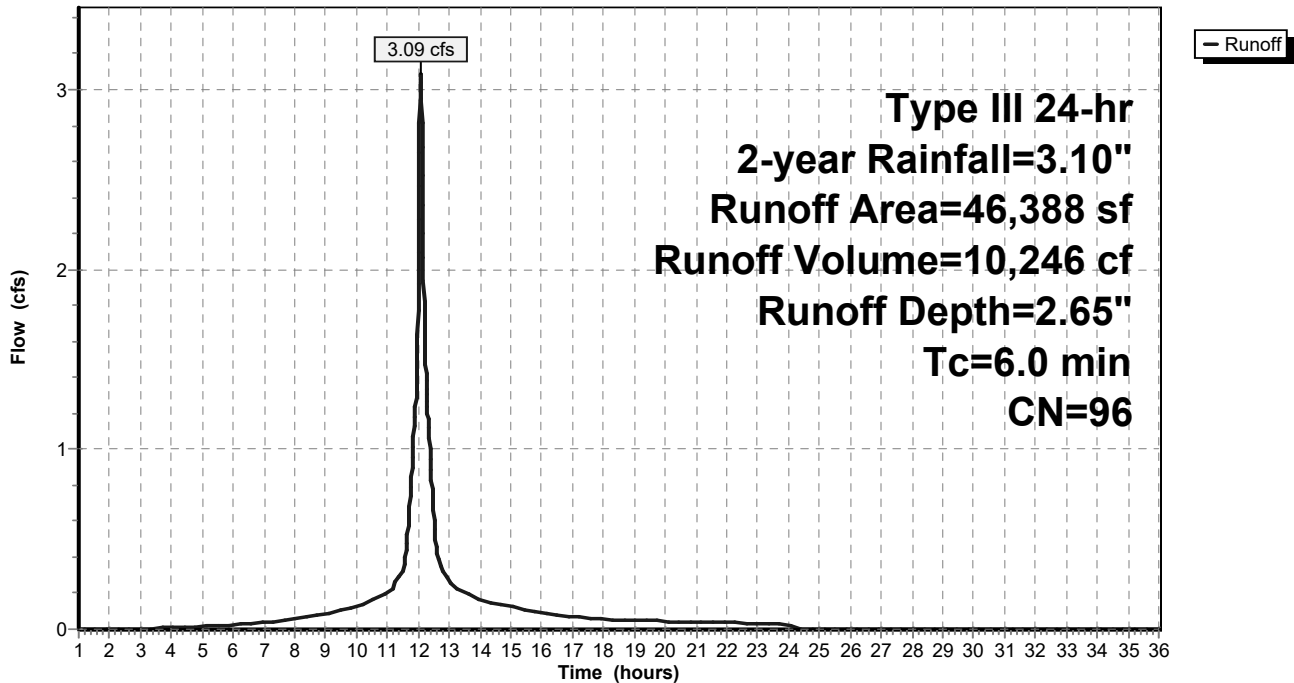

Spofford Post-Development

Prepared by Weston & Sampson

HydroCAD® 10.10-6a s/n 00455 © 2020 HydroCAD Software Solutions LLC

Type III 24-hr 2-year Rainfall=3.10"

Printed 11/5/2021

Page 24

Summary for Subcatchment 16S: Sub 16

Runoff = 0.69 cfs @ 12.09 hrs, Volume= 2,197 cf, Depth= 2.35"
 Routed to Pond 4P : Detention Chambers sC 740

Runoff by SCS TR-20 method, UH=SCS, Weighted-CN, Time Span= 1.00-36.00 hrs, dt= 0.01 hrs
 Type III 24-hr 2-year Rainfall=3.10"

Area (sf)	CN	Description
10,400	98	Paved parking, HSG A
* 822	30	Grass
11,222	93	Weighted Average
822		7.32% Pervious Area
10,400		92.68% Impervious Area

Tc (min)	Length (feet)	Slope (ft/ft)	Velocity (ft/sec)	Capacity (cfs)	Description
6.0					Direct Entry,

Subcatchment 16S: Sub 16

Hydrograph

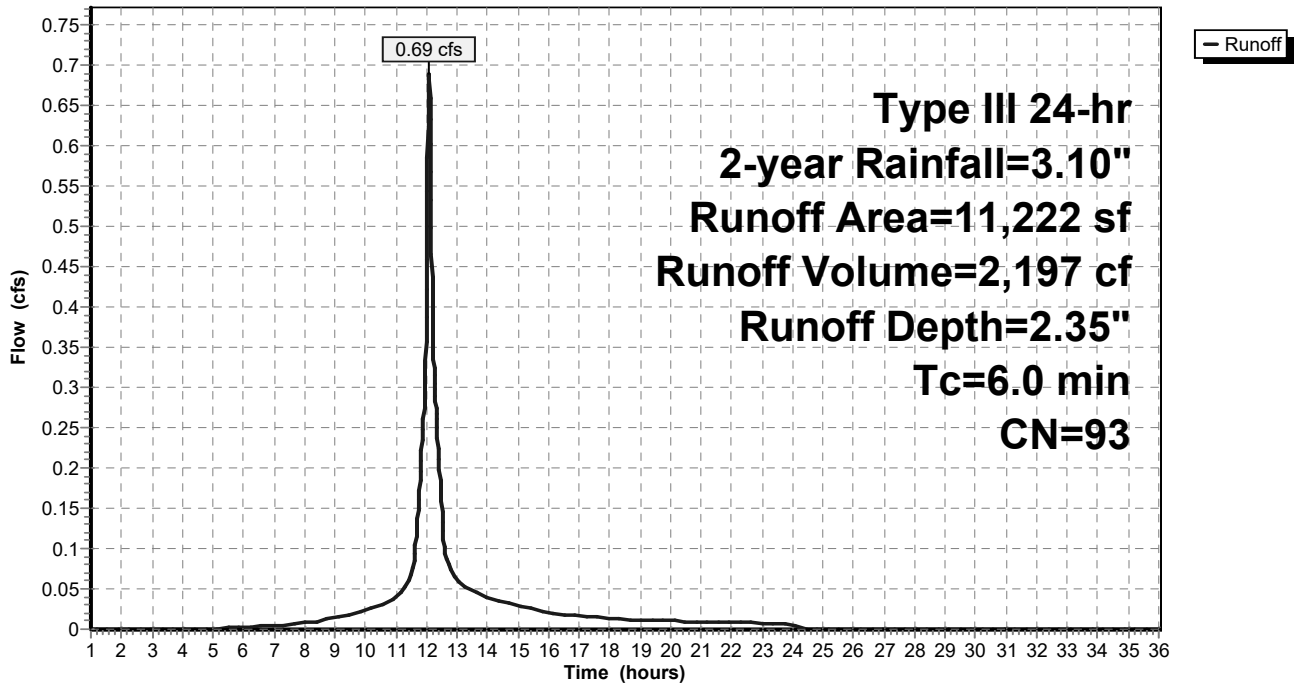

Spofford Post-Development

Prepared by Weston & Sampson

HydroCAD® 10.10-6a s/n 00455 © 2020 HydroCAD Software Solutions LLC

Type III 24-hr 2-year Rainfall=3.10"

Printed 11/5/2021

Page 25

Summary for Subcatchment 17S: Sub 17

Runoff = 0.74 cfs @ 12.08 hrs, Volume= 2,493 cf, Depth= 2.76"
Routed to Pond 4P : Detention Chambers sC 740

Runoff by SCS TR-20 method, UH=SCS, Weighted-CN, Time Span= 1.00-36.00 hrs, dt= 0.01 hrs
Type III 24-hr 2-year Rainfall=3.10"

Area (sf)	CN	Description
* 155	30	Grass
10,696	98	Paved parking, HSG A
10,851	97	Weighted Average
155		1.43% Pervious Area
10,696		98.57% Impervious Area

Tc (min)	Length (feet)	Slope (ft/ft)	Velocity (ft/sec)	Capacity (cfs)	Description
6.0					Direct Entry,

Subcatchment 17S: Sub 17

Hydrograph

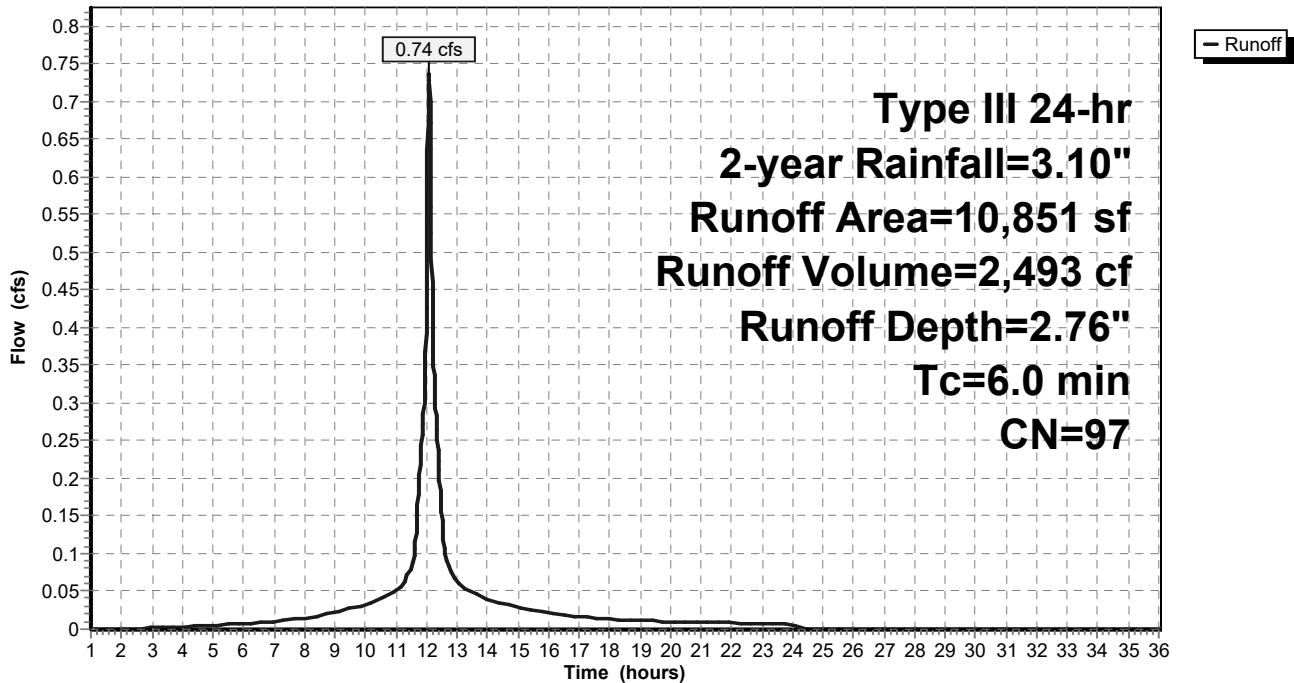

Spofford Post-Development

Prepared by Weston & Sampson

HydroCAD® 10.10-6a s/n 00455 © 2020 HydroCAD Software Solutions LLC

Type III 24-hr 2-year Rainfall=3.10"

Printed 11/5/2021

Page 26

Summary for Subcatchment 18S: Sub 18

Runoff = 0.00 cfs @ 1.00 hrs, Volume= 0 cf, Depth= 0.00"
 Routed to Link 4L : Vernal Pool Wetlands

Runoff by SCS TR-20 method, UH=SCS, Weighted-CN, Time Span= 1.00-36.00 hrs, dt= 0.01 hrs
 Type III 24-hr 2-year Rainfall=3.10"

	Area (sf)	CN	Description
*	5,866	30	Grass
	397	98	Paved parking, HSG A
	4,427	30	Woods, Good, HSG A
	10,690	33	Weighted Average
	10,293		96.29% Pervious Area
	397		3.71% Impervious Area

Tc (min)	Length (feet)	Slope (ft/ft)	Velocity (ft/sec)	Capacity (cfs)	Description
6.0					Direct Entry,

Subcatchment 18S: Sub 18

Hydrograph

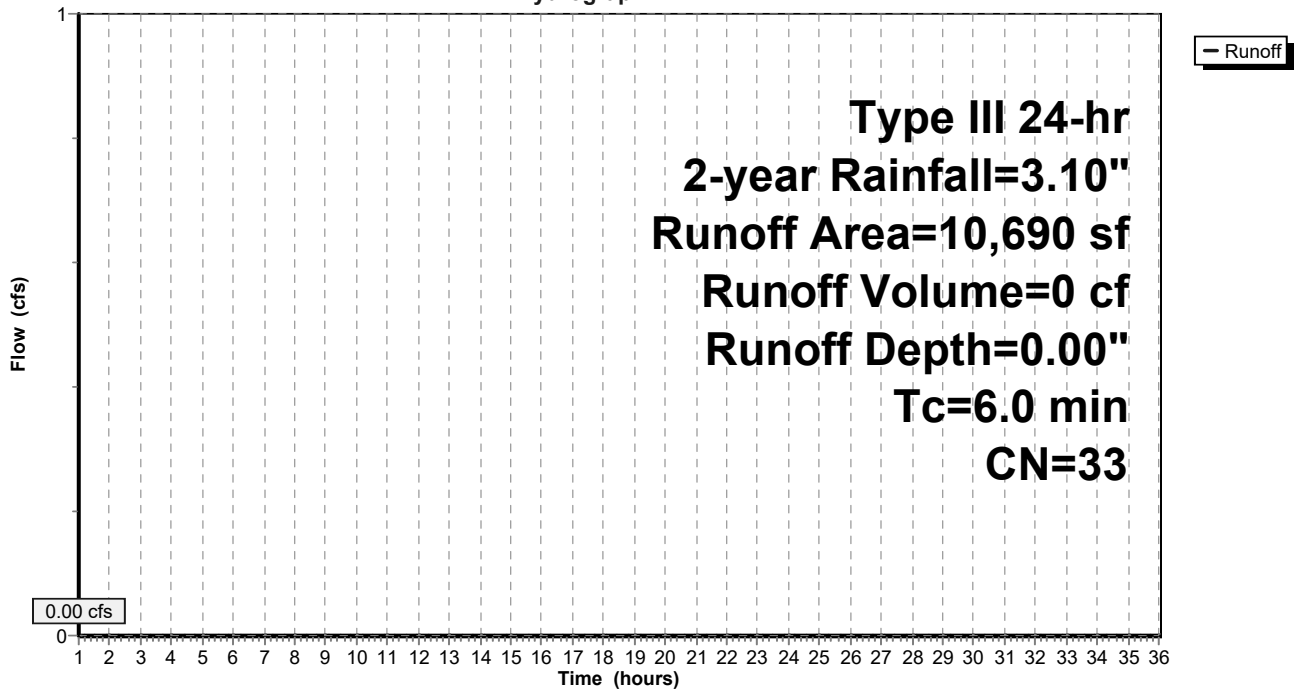

Spofford Post-Development

Prepared by Weston & Sampson

HydroCAD® 10.10-6a s/n 00455 © 2020 HydroCAD Software Solutions LLC

Type III 24-hr 2-year Rainfall=3.10"

Printed 11/5/2021

Page 27

Summary for Subcatchment 19S: Sub 19

Runoff = 0.00 cfs @ 1.00 hrs, Volume= 0 cf, Depth= 0.00"

Routed to Link 2L : Isolated Wetlands

Runoff by SCS TR-20 method, UH=SCS, Weighted-CN, Time Span= 1.00-36.00 hrs, dt= 0.01 hrs
 Type III 24-hr 2-year Rainfall=3.10"

	Area (sf)	CN	Description
*	3,953	30	Grass
	3,953		100.00% Pervious Area

Tc (min)	Length (feet)	Slope (ft/ft)	Velocity (ft/sec)	Capacity (cfs)	Description
6.0					Direct Entry,

Subcatchment 19S: Sub 19

Hydrograph

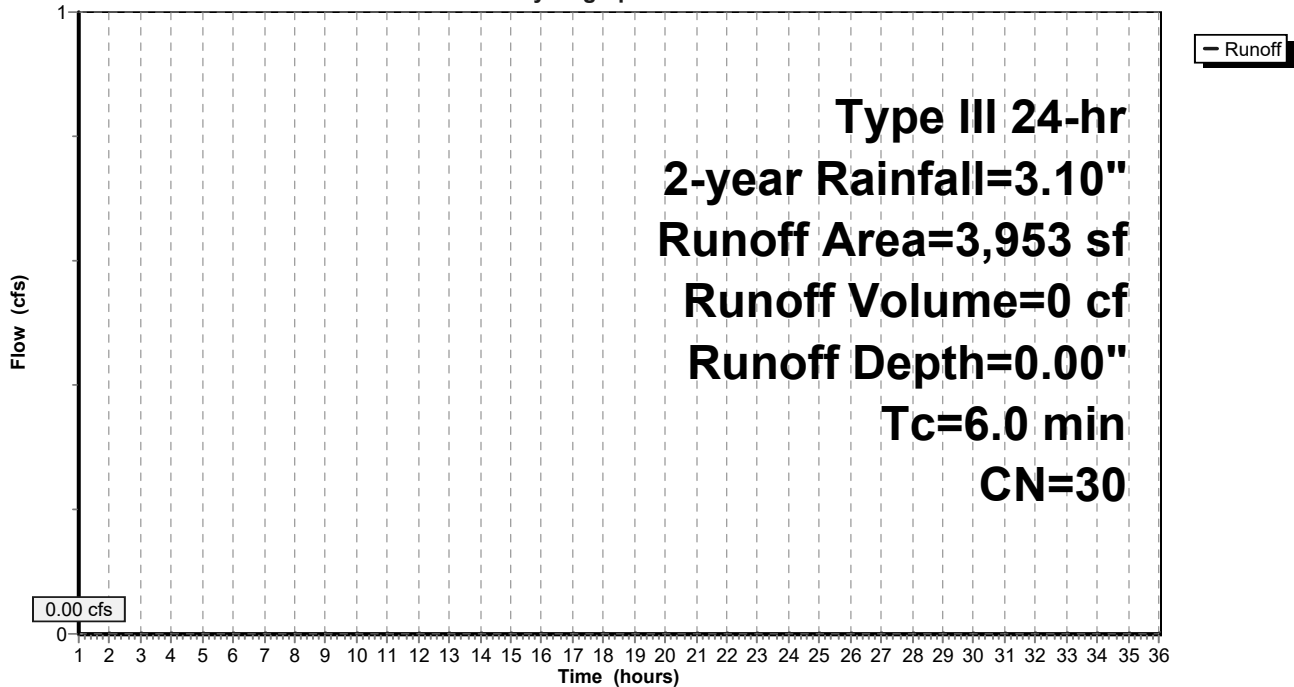

Spofford Post-Development

Prepared by Weston & Sampson

HydroCAD® 10.10-6a s/n 00455 © 2020 HydroCAD Software Solutions LLC

Type III 24-hr 2-year Rainfall=3.10"

Printed 11/5/2021

Page 28

Summary for Pond 3P: Sediment Forebay

Inflow Area = 46,388 sf, 96.62% Impervious, Inflow Depth = 2.65" for 2-year event
 Inflow = 3.09 cfs @ 12.08 hrs, Volume= 10,246 cf
 Outflow = 3.01 cfs @ 12.10 hrs, Volume= 9,872 cf, Atten= 3%, Lag= 1.1 min
 Primary = 3.01 cfs @ 12.10 hrs, Volume= 9,872 cf
 Routed to Pond 4P : Detention Chambers sC 740
 Secondary = 0.00 cfs @ 1.00 hrs, Volume= 0 cf
 Routed to Pond 4P : Detention Chambers sC 740

Routing by Dyn-Stor-Ind method, Time Span= 1.00-36.00 hrs, dt= 0.01 hrs
 Peak Elev= 133.74' @ 12.10 hrs Surf.Area= 1,123 sf Storage= 661 cf

Plug-Flow detention time= 40.0 min calculated for 9,872 cf (96% of inflow)
 Center-of-Mass det. time= 18.2 min (793.2 - 775.0)

Volume	Invert	Avail.Storage	Storage Description
#1	133.00'	979 cf	Custom Stage Data (Irregular) Listed below (Recalc)

Elevation (feet)	Surf.Area (sq-ft)	Perim. (feet)	Inc.Store (cubic-feet)	Cum.Store (cubic-feet)	Wet.Area (sq-ft)
133.00	687	186.0	0	0	687
134.00	1,304	215.0	979	979	1,634

Device	Routing	Invert	Outlet Devices
#1	Primary	128.65'	24.0" Round Culvert L= 29.0' CPP, projecting, no headwall, Ke= 0.900 Inlet / Outlet Invert= 128.65' / 128.50' S= 0.0052 '/' Cc= 0.900 n= 0.013 Corrugated PE, smooth interior, Flow Area= 3.14 sf
#2	Device 1	133.46'	24.0" Horiz. Orifice/Grate C= 0.600 Limited to weir flow at low heads
#3	Secondary	134.00'	215.0' long x 2.0' breadth Broad-Crested Rectangular Weir Head (feet) 0.20 0.40 0.60 0.80 1.00 1.20 1.40 1.60 1.80 2.00 2.50 3.00 3.50 Coef. (English) 2.54 2.61 2.61 2.60 2.66 2.70 2.77 2.89 2.88 2.85 3.07 3.20 3.32

Primary OutFlow Max=3.00 cfs @ 12.10 hrs HW=133.74' TW=128.99' (Dynamic Tailwater)

- ↑1=Culvert (Passes 3.00 cfs of 24.14 cfs potential flow)
- ↑2=Orifice/Grate (Weir Controls 3.00 cfs @ 1.72 fps)

Secondary OutFlow Max=0.00 cfs @ 1.00 hrs HW=133.00' TW=127.76' (Dynamic Tailwater)

- ↑3=Broad-Crested Rectangular Weir (Controls 0.00 cfs)

Pond 3P: Sediment Forebay

Hydrograph

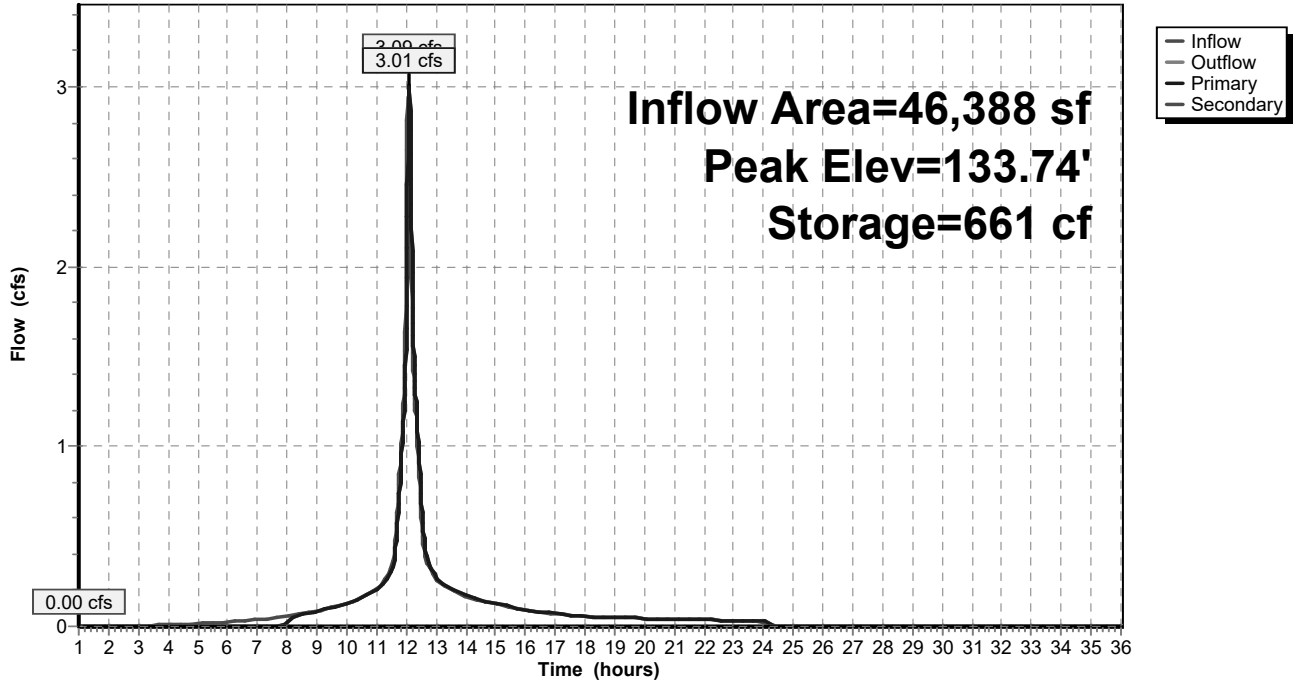

Summary for Pond 4P: Detention Chambers sC 740

Inflow Area = 235,054 sf, 90.09% Impervious, Inflow Depth = 2.27" for 2-year event
 Inflow = 13.27 cfs @ 12.09 hrs, Volume= 44,498 cf
 Outflow = 7.49 cfs @ 12.21 hrs, Volume= 44,195 cf, Atten= 44%, Lag= 7.3 min
 Primary = 7.49 cfs @ 12.21 hrs, Volume= 44,195 cf
 Routed to Link 4L : Vernal Pool Wetlands

Routing by Dyn-Stor-Ind method, Time Span= 1.00-36.00 hrs, dt= 0.01 hrs
 Peak Elev= 129.10' @ 12.21 hrs Surf.Area= 14,134 sf Storage= 12,639 cf

Plug-Flow detention time= 111.6 min calculated for 44,195 cf (99% of inflow)
 Center-of-Mass det. time= 107.2 min (891.3 - 784.1)

Volume	Invert	Avail.Storage	Storage Description
#1A	127.76'	12,437 cf	120.25"W x 117.54"L x 3.50"H Field A 49,468 cf Overall - 18,376 cf Embedded = 31,092 cf x 40.0% Voids
#2A	128.26'	18,376 cf	ADS_StormTech SC-740 +Cap x 400 Inside #1 Effective Size= 44.6"W x 30.0"H => 6.45 sf x 7.12'L = 45.9 cf Overall Size= 51.0"W x 30.0"H x 7.56'L with 0.44' Overlap 400 Chambers in 25 Rows
		30,813 cf	Total Available Storage

Storage Group A created with Chamber Wizard

Device	Routing	Invert	Outlet Devices
#1	Primary	127.66'	24.0" Round Culvert L= 92.0' CPP, projecting, no headwall, Ke= 0.900 Inlet / Outlet Invert= 127.66' / 127.15' S= 0.0055 '/' Cc= 0.900 n= 0.013 Corrugated PE, smooth interior, Flow Area= 3.14 sf
#2	Device 1	127.76'	4.0" Vert. Orifice/Grate C= 0.600 Limited to weir flow at low heads
#3	Device 1	128.39'	4.0' long x 0.5' breadth Broad-Crested Rectangular Weir Head (feet) 0.20 0.40 0.60 0.80 1.00 Coef. (English) 2.80 2.92 3.08 3.30 3.32

Primary OutFlow Max=7.49 cfs @ 12.21 hrs HW=129.10' TW=0.00' (Dynamic Tailwater)

- 1=Culvert (Barrel Controls 7.49 cfs @ 4.34 fps)
- 2=Orifice/Grate (Passes < 0.45 cfs potential flow)
- 3=Broad-Crested Rectangular Weir(Passes < 7.61 cfs potential flow)

Pond 4P: Detention Chambers sC 740

Hydrograph

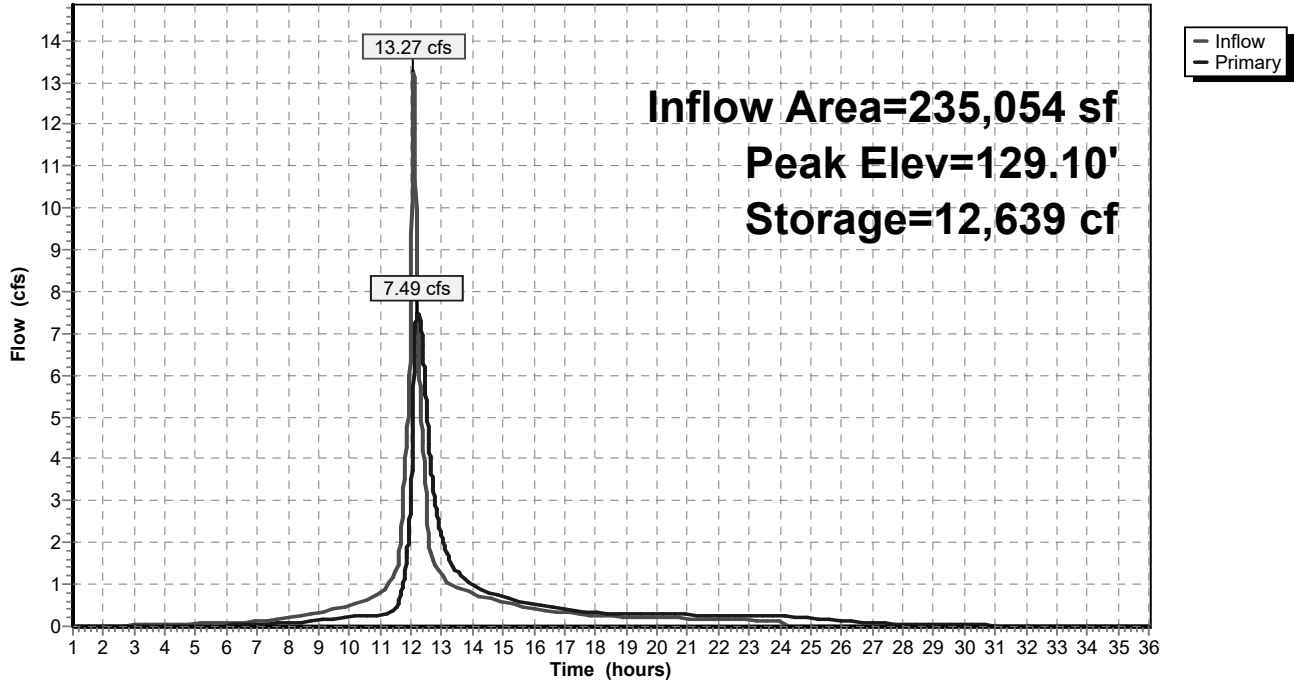

Summary for Link 1L: Leaching CB

Inflow Area = 9,774 sf, 0.00% Impervious, Inflow Depth = 0.00" for 2-year event
Inflow = 0.00 cfs @ 1.00 hrs, Volume= 0 cf
Primary = 0.00 cfs @ 1.00 hrs, Volume= 0 cf, Atten= 0%, Lag= 0.0 min

Primary outflow = Inflow, Time Span= 1.00-36.00 hrs, dt= 0.01 hrs

Link 1L: Leaching CB

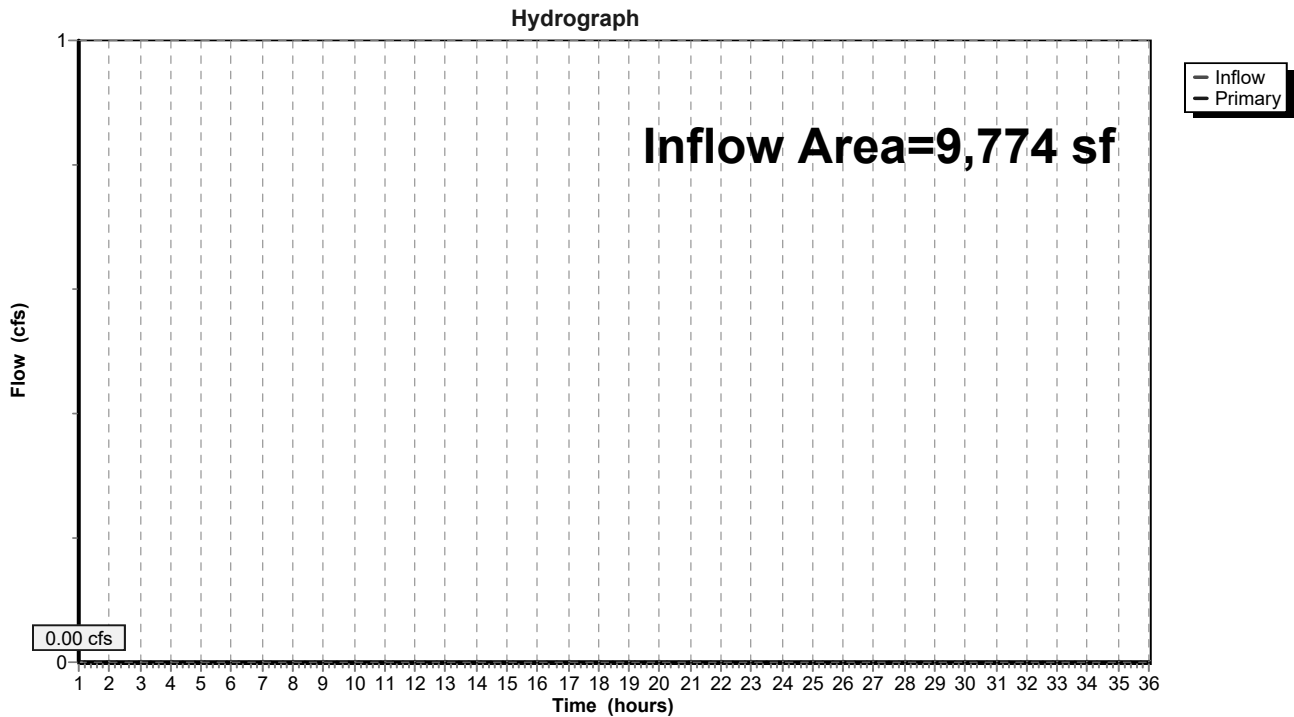

Summary for Link 2L: Isolated Wetlands

Inflow Area = 9,423 sf, 0.00% Impervious, Inflow Depth = 0.00" for 2-year event
Inflow = 0.00 cfs @ 1.00 hrs, Volume= 0 cf
Primary = 0.00 cfs @ 1.00 hrs, Volume= 0 cf, Atten= 0%, Lag= 0.0 min

Primary outflow = Inflow, Time Span= 1.00-36.00 hrs, dt= 0.01 hrs

Link 2L: Isolated Wetlands

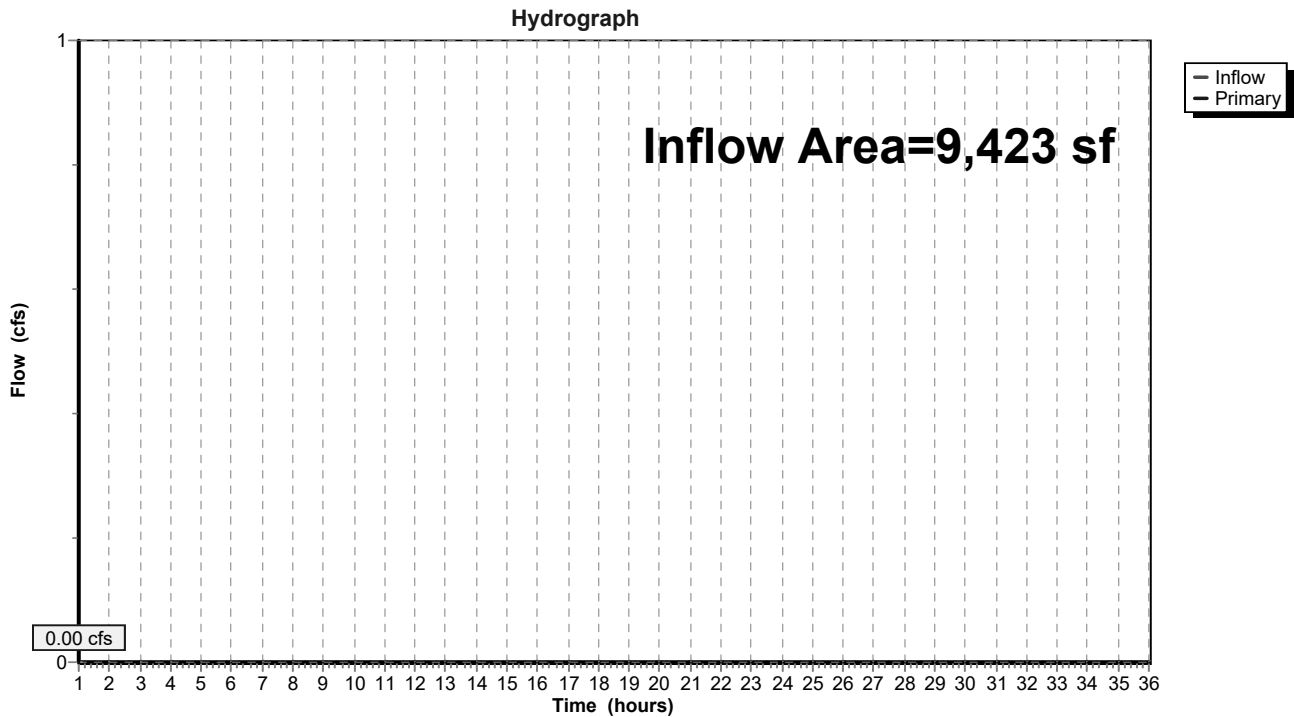

Summary for Link 3L: Spofford Pond Wetlands

Inflow Area = 42,576 sf, 6.11% Impervious, Inflow Depth = 0.00" for 2-year event
Inflow = 0.00 cfs @ 1.00 hrs, Volume= 0 cf
Primary = 0.00 cfs @ 1.00 hrs, Volume= 0 cf, Atten= 0%, Lag= 0.0 min

Primary outflow = Inflow, Time Span= 1.00-36.00 hrs, dt= 0.01 hrs

Link 3L: Spofford Pond Wetlands

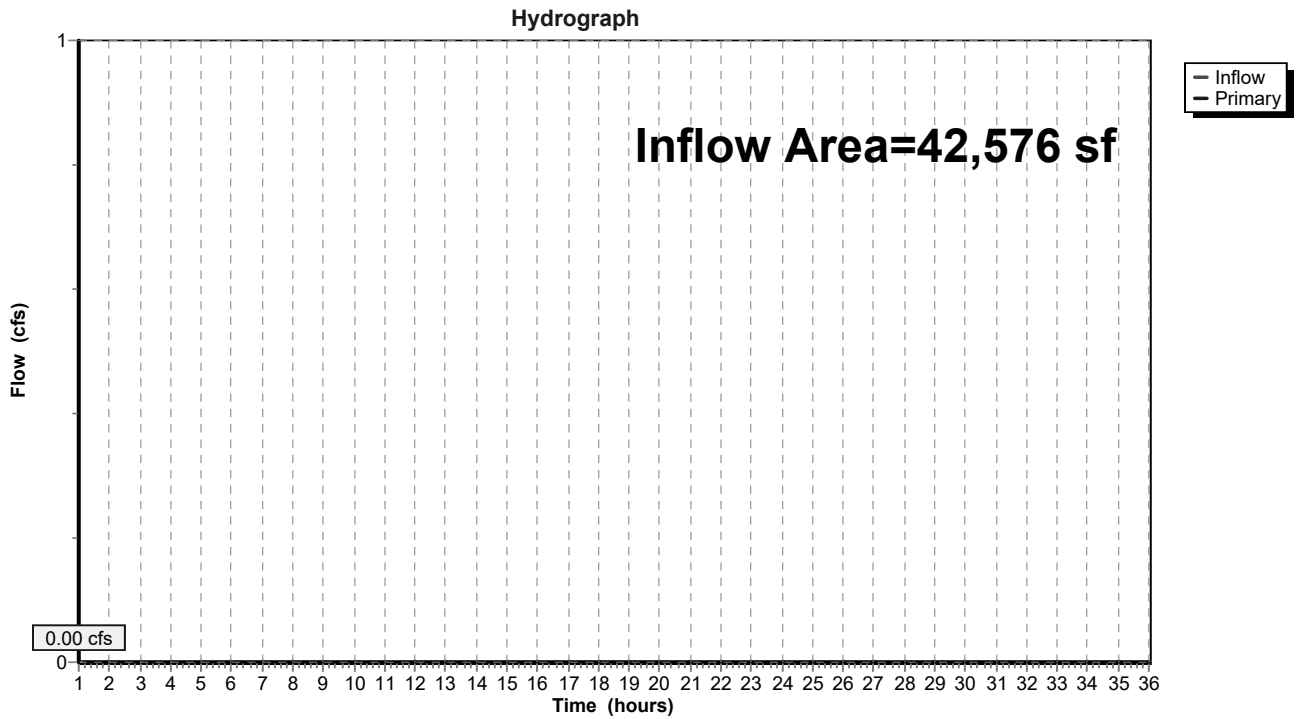

Summary for Link 4L: Vernal Pool Wetlands

Inflow Area = 245,744 sf, 86.33% Impervious, Inflow Depth > 2.16" for 2-year event
Inflow = 7.49 cfs @ 12.21 hrs, Volume= 44,195 cf
Primary = 7.49 cfs @ 12.21 hrs, Volume= 44,195 cf, Atten= 0%, Lag= 0.0 min
Routed to nonexistent node 25L

Primary outflow = Inflow, Time Span= 1.00-36.00 hrs, dt= 0.01 hrs

Link 4L: Vernal Pool Wetlands

Hydrograph

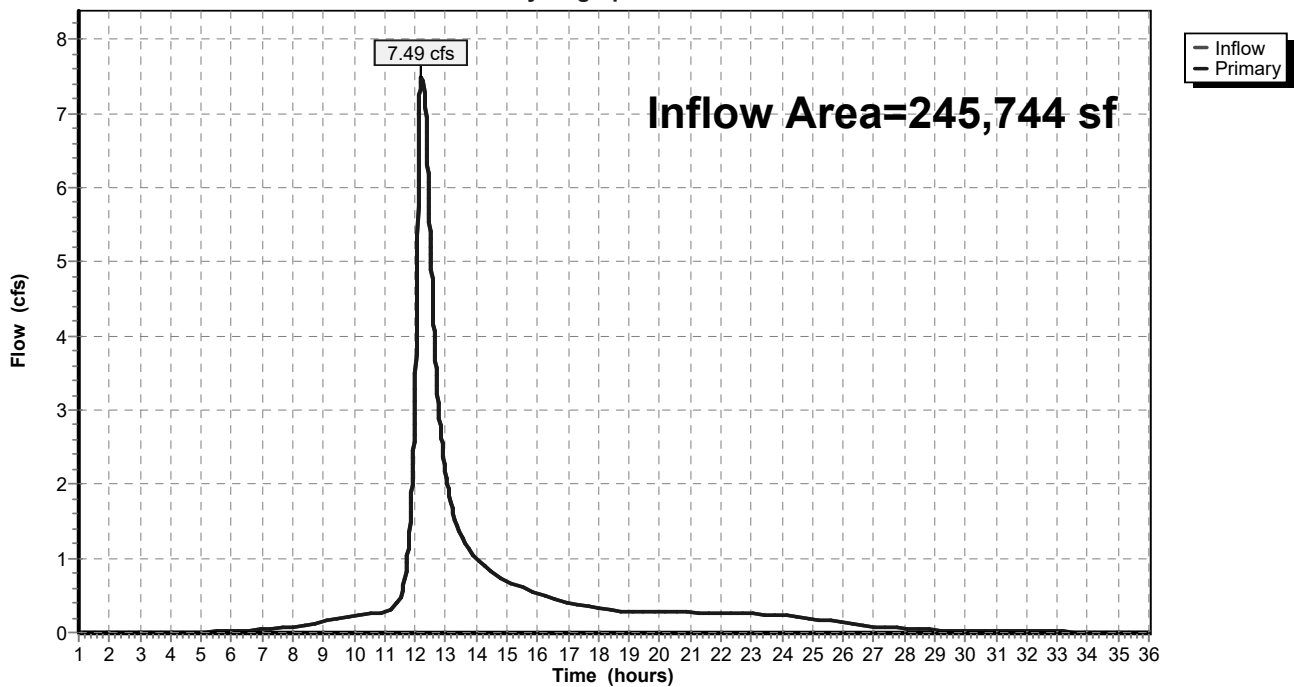

Spofford Post-Development

Prepared by Weston & Sampson

HydroCAD® 10.10-6a s/n 00455 © 2020 HydroCAD Software Solutions LLC

Type III 24-hr 10-year Rainfall=4.70"

Printed 11/5/2021

Page 36

Time span=1.00-36.00 hrs, dt=0.01 hrs, 3501 points
Runoff by SCS TR-20 method, UH=SCS, Weighted-CN
Reach routing by Dyn-Stor-Ind method - Pond routing by Dyn-Stor-Ind method

Subcatchment1S: Roof	Runoff Area=71,161 sf 100.00% Impervious Runoff Depth>4.46" Tc=6.0 min CN=98 Runoff=7.51 cfs 26,470 cf
Subcatchment2S: Sub 2	Runoff Area=9,774 sf 0.00% Impervious Runoff Depth=0.00" Tc=6.0 min CN=30 Runoff=0.00 cfs 0 cf
Subcatchment3S: Sub 3	Runoff Area=24,730 sf 73.09% Impervious Runoff Depth=2.63" Tc=6.0 min CN=80 Runoff=1.75 cfs 5,426 cf
Subcatchment4S: Sub 4	Runoff Area=13,951 sf 62.30% Impervious Runoff Depth=1.97" Tc=6.0 min CN=72 Runoff=0.73 cfs 2,290 cf
Subcatchment5S: Sub 5	Runoff Area=10,142 sf 79.94% Impervious Runoff Depth=3.00" Tc=6.0 min CN=84 Runoff=0.81 cfs 2,533 cf
Subcatchment6S: Sub 6	Runoff Area=18,754 sf 13.86% Impervious Runoff Depth=0.14" Tc=6.0 min CN=39 Runoff=0.01 cfs 224 cf
Subcatchment7S: Sub 7	Runoff Area=4,674 sf 100.00% Impervious Runoff Depth>4.46" Tc=6.0 min CN=98 Runoff=0.49 cfs 1,739 cf
Subcatchment8S: Sub 8	Runoff Area=23,822 sf 0.00% Impervious Runoff Depth=0.00" Tc=6.0 min CN=30 Runoff=0.00 cfs 0 cf
Subcatchment9S: Sub 9	Runoff Area=9,379 sf 95.68% Impervious Runoff Depth=4.12" Tc=6.0 min CN=95 Runoff=0.96 cfs 3,222 cf
Subcatchment10S: Sub 10	Runoff Area=18,532 sf 69.05% Impervious Runoff Depth=2.37" Tc=6.0 min CN=77 Runoff=1.18 cfs 3,666 cf
Subcatchment11S: Sub 11	Runoff Area=6,808 sf 98.43% Impervious Runoff Depth=4.35" Tc=6.0 min CN=97 Runoff=0.71 cfs 2,467 cf
Subcatchment12S: Sub 12	Runoff Area=5,470 sf 0.00% Impervious Runoff Depth=0.00" Tc=6.0 min CN=30 Runoff=0.00 cfs 0 cf
Subcatchment13S: Sub 13	Runoff Area=3,318 sf 87.70% Impervious Runoff Depth=3.59" Tc=6.0 min CN=90 Runoff=0.31 cfs 992 cf
Subcatchment14S: Sub 14	Runoff Area=3,898 sf 96.02% Impervious Runoff Depth=4.12" Tc=6.0 min CN=95 Runoff=0.40 cfs 1,339 cf
Subcatchment15S: Sub 15	Runoff Area=46,388 sf 96.62% Impervious Runoff Depth=4.23" Tc=6.0 min CN=96 Runoff=4.80 cfs 16,369 cf
Subcatchment16S: Sub 16	Runoff Area=11,222 sf 92.68% Impervious Runoff Depth=3.90" Tc=6.0 min CN=93 Runoff=1.11 cfs 3,651 cf

Spofford Post-Development

Prepared by Weston & Sampson

HydroCAD® 10.10-6a s/n 00455 © 2020 HydroCAD Software Solutions LLC

Type III 24-hr 10-year Rainfall=4.70"

Printed 11/5/2021

Page 37

Subcatchment 17S: Sub 17	Runoff Area=10,851 sf 98.57% Impervious Runoff Depth=4.35" Tc=6.0 min CN=97 Runoff=1.14 cfs 3,932 cf
Subcatchment 18S: Sub 18	Runoff Area=10,690 sf 3.71% Impervious Runoff Depth=0.02" Tc=6.0 min CN=33 Runoff=0.00 cfs 17 cf
Subcatchment 19S: Sub 19	Runoff Area=3,953 sf 0.00% Impervious Runoff Depth=0.00" Tc=6.0 min CN=30 Runoff=0.00 cfs 0 cf
Pond 3P: Sediment Forebay	Peak Elev=133.83' Storage=772 cf Inflow=4.80 cfs 16,369 cf Primary=4.70 cfs 15,995 cf Secondary=0.00 cfs 0 cf Outflow=4.70 cfs 15,995 cf
Pond 4P: Detention Chambers sC 740	Peak Elev=129.58' Storage=17,879 cf Inflow=21.73 cfs 73,721 cf Outflow=11.53 cfs 73,375 cf
Link 1L: Leaching CB	Inflow=0.00 cfs 0 cf Primary=0.00 cfs 0 cf
Link 2L: Isolated Wetlands	Inflow=0.00 cfs 0 cf Primary=0.00 cfs 0 cf
Link 3L: Spofford Pond Wetlands	Inflow=0.01 cfs 224 cf Primary=0.01 cfs 224 cf
Link 4L: Vernal Pool Wetlands	Inflow=11.53 cfs 73,393 cf Primary=11.53 cfs 73,393 cf
Total Runoff Area = 307,517 sf Runoff Volume = 74,337 cf Average Runoff Depth = 2.90" 30.17% Pervious = 92,770 sf 69.83% Impervious = 214,747 sf	

Spofford Post-Development

Prepared by Weston & Sampson

HydroCAD® 10.10-6a s/n 00455 © 2020 HydroCAD Software Solutions LLC

Type III 24-hr 10-year Rainfall=4.70"

Printed 11/5/2021

Page 38

Summary for Subcatchment 1S: Roof

Runoff = 7.51 cfs @ 12.08 hrs, Volume= 26,470 cf, Depth> 4.46"
Routed to Pond 4P : Detention Chambers sC 740

Runoff by SCS TR-20 method, UH=SCS, Weighted-CN, Time Span= 1.00-36.00 hrs, dt= 0.01 hrs
Type III 24-hr 10-year Rainfall=4.70"

Area (sf)	CN	Description
71,161	98	Roofs, HSG A
71,161		100.00% Impervious Area

Tc (min)	Length (feet)	Slope (ft/ft)	Velocity (ft/sec)	Capacity (cfs)	Description
6.0					Direct Entry,

Subcatchment 1S: Roof

Hydrograph

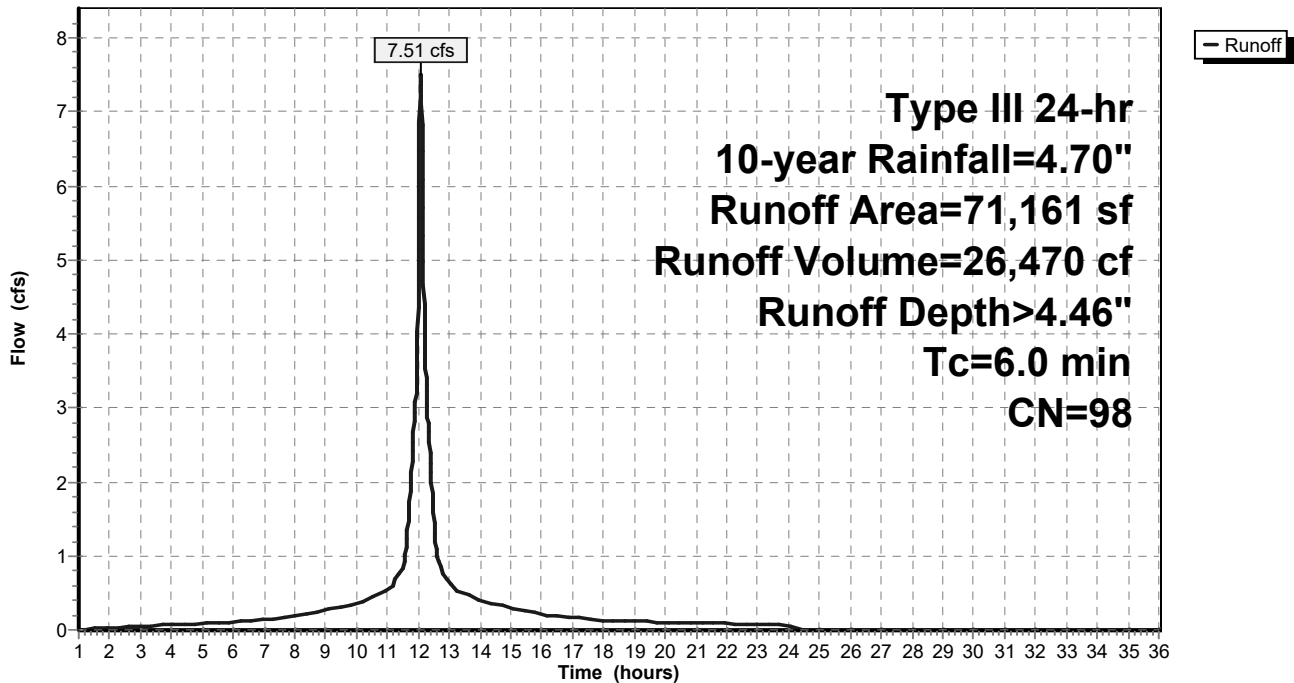

Spofford Post-Development

Prepared by Weston & Sampson

HydroCAD® 10.10-6a s/n 00455 © 2020 HydroCAD Software Solutions LLC

Type III 24-hr 10-year Rainfall=4.70"

Printed 11/5/2021

Page 39

Summary for Subcatchment 2S: Sub 2

Runoff = 0.00 cfs @ 24.02 hrs, Volume= 0 cf, Depth= 0.00"

Routed to Link 1L : Leaching CB

Runoff by SCS TR-20 method, UH=SCS, Weighted-CN, Time Span= 1.00-36.00 hrs, dt= 0.01 hrs
Type III 24-hr 10-year Rainfall=4.70"

Area (sf)	CN	Description
* 9,774	30	Grass
9,774		100.00% Pervious Area

Tc (min)	Length (feet)	Slope (ft/ft)	Velocity (ft/sec)	Capacity (cfs)	Description
6.0					Direct Entry,

Subcatchment 2S: Sub 2

Hydrograph

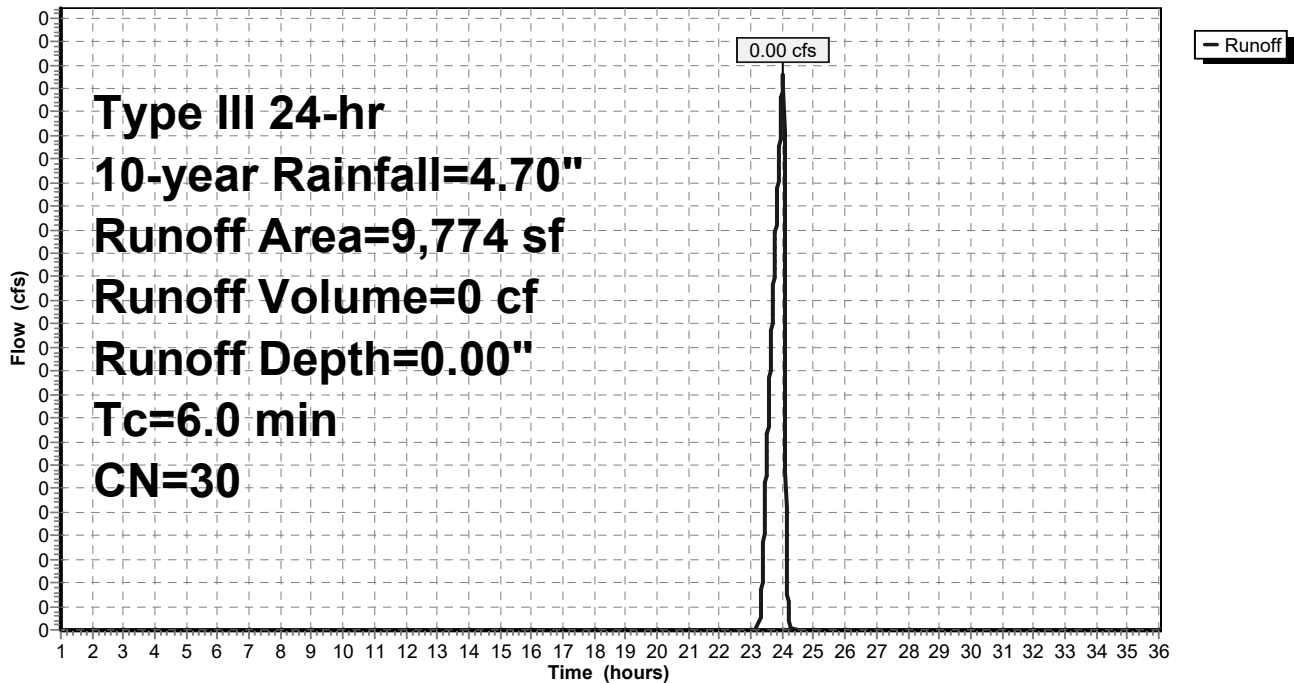

Spofford Post-Development

Prepared by Weston & Sampson

HydroCAD® 10.10-6a s/n 00455 © 2020 HydroCAD Software Solutions LLC

Type III 24-hr 10-year Rainfall=4.70"

Printed 11/5/2021

Page 40

Summary for Subcatchment 3S: Sub 3

Runoff = 1.75 cfs @ 12.09 hrs, Volume= 5,426 cf, Depth= 2.63"
 Routed to Pond 4P : Detention Chambers sC 740

Runoff by SCS TR-20 method, UH=SCS, Weighted-CN, Time Span= 1.00-36.00 hrs, dt= 0.01 hrs
 Type III 24-hr 10-year Rainfall=4.70"

Area (sf)	CN	Description
8,972	98	Paved parking, HSG A
* 9,104	98	Turf (impervious)
* 5,760	30	Grass
894	30	Woods, Good, HSG A
24,730	80	Weighted Average
6,654		26.91% Pervious Area
18,076		73.09% Impervious Area

Tc (min)	Length (feet)	Slope (ft/ft)	Velocity (ft/sec)	Capacity (cfs)	Description
6.0					Direct Entry,

Subcatchment 3S: Sub 3

Hydrograph

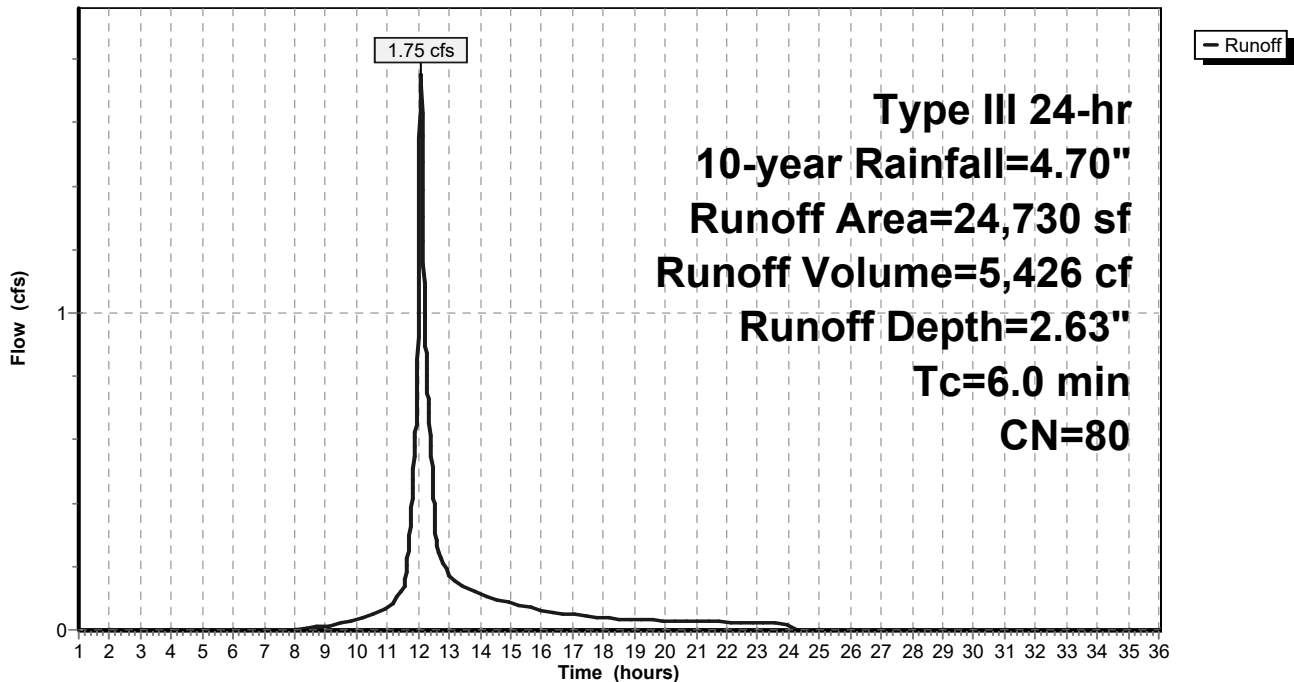

Spofford Post-Development

Prepared by Weston & Sampson

HydroCAD® 10.10-6a s/n 00455 © 2020 HydroCAD Software Solutions LLC

Type III 24-hr 10-year Rainfall=4.70"

Printed 11/5/2021

Page 41

Summary for Subcatchment 4S: Sub 4

Runoff = 0.73 cfs @ 12.09 hrs, Volume= 2,290 cf, Depth= 1.97"
 Routed to Pond 4P : Detention Chambers sC 740

Runoff by SCS TR-20 method, UH=SCS, Weighted-CN, Time Span= 1.00-36.00 hrs, dt= 0.01 hrs
 Type III 24-hr 10-year Rainfall=4.70"

Area (sf)	CN	Description
8,691	98	Paved parking, HSG A
2,060	30	Woods, Good, HSG A
* 3,200	30	Grass
13,951	72	Weighted Average
5,260		37.70% Pervious Area
8,691		62.30% Impervious Area

Tc (min)	Length (feet)	Slope (ft/ft)	Velocity (ft/sec)	Capacity (cfs)	Description
6.0					Direct Entry,

Subcatchment 4S: Sub 4

Hydrograph

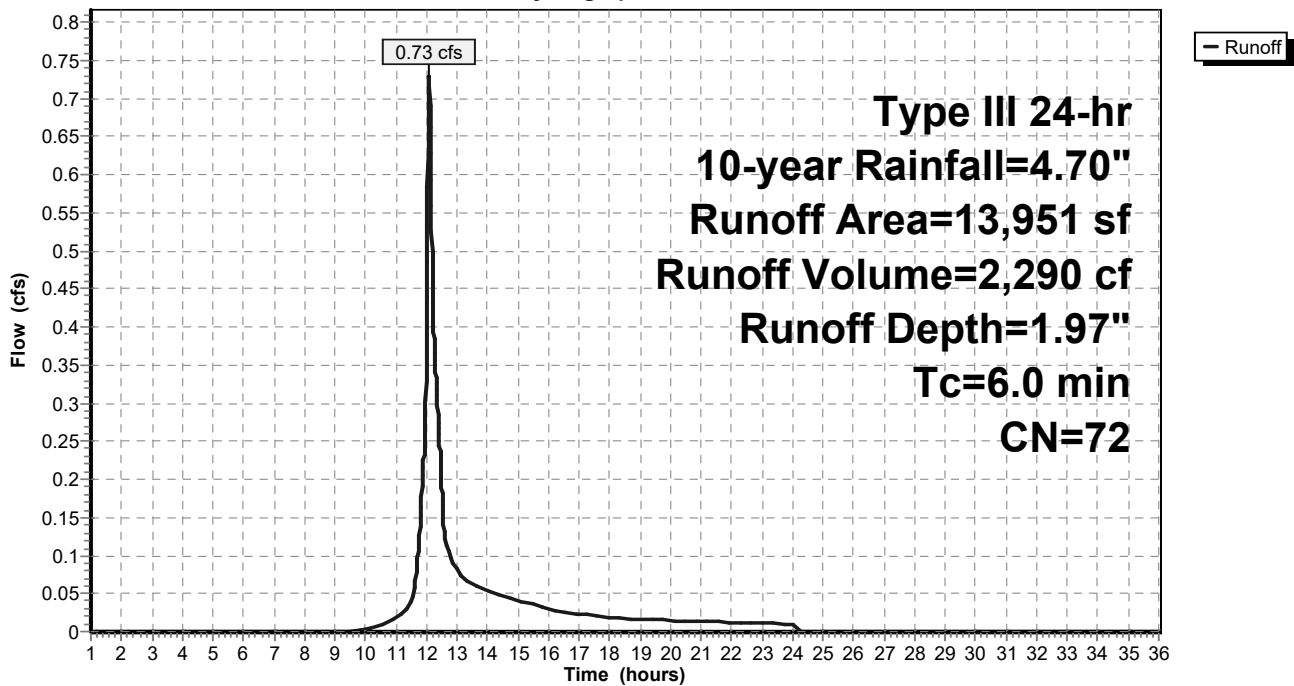

Spofford Post-Development

Prepared by Weston & Sampson

HydroCAD® 10.10-6a s/n 00455 © 2020 HydroCAD Software Solutions LLC

Type III 24-hr 10-year Rainfall=4.70"

Printed 11/5/2021

Page 42

Summary for Subcatchment 5S: Sub 5

Runoff = 0.81 cfs @ 12.09 hrs, Volume= 2,533 cf, Depth= 3.00"
 Routed to Pond 4P : Detention Chambers sC 740

Runoff by SCS TR-20 method, UH=SCS, Weighted-CN, Time Span= 1.00-36.00 hrs, dt= 0.01 hrs
 Type III 24-hr 10-year Rainfall=4.70"

Area (sf)	CN	Description
8,108	98	Paved parking, HSG A
* 2,034	30	Grass
10,142	84	Weighted Average
2,034		20.06% Pervious Area
8,108		79.94% Impervious Area

Tc (min)	Length (feet)	Slope (ft/ft)	Velocity (ft/sec)	Capacity (cfs)	Description
6.0					Direct Entry,

Subcatchment 5S: Sub 5

Hydrograph

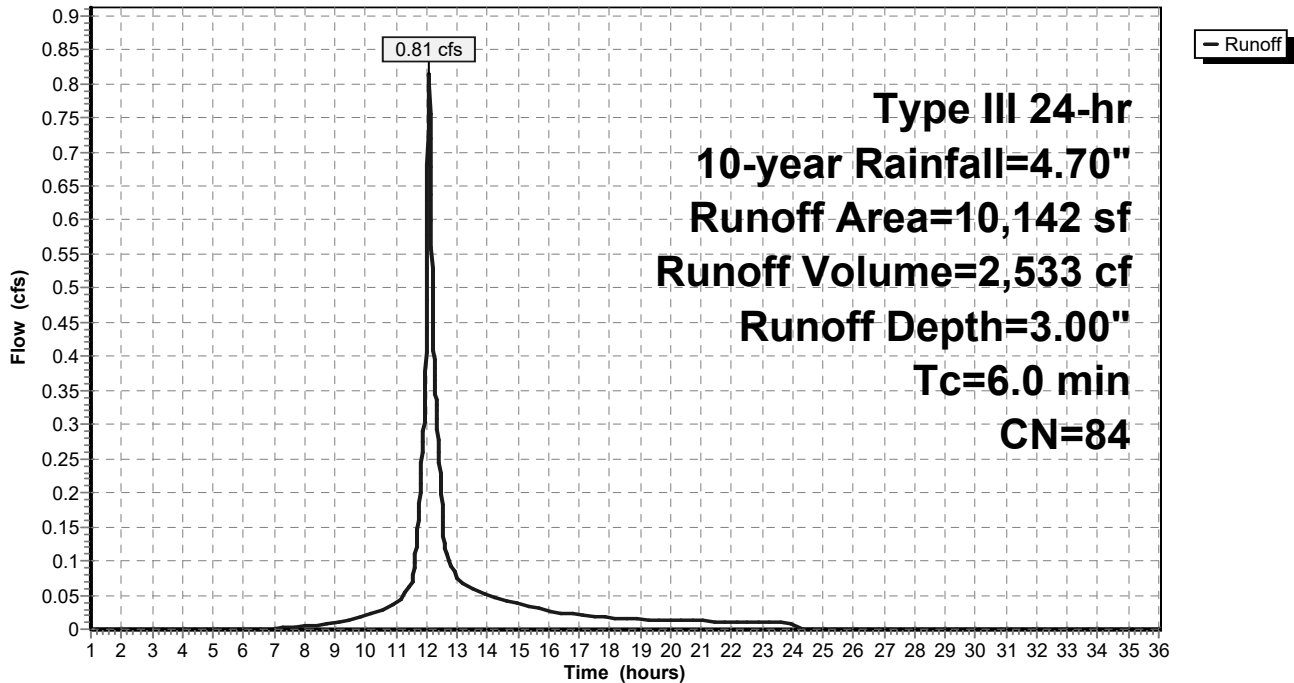

Spofford Post-Development

Prepared by Weston & Sampson

HydroCAD® 10.10-6a s/n 00455 © 2020 HydroCAD Software Solutions LLC

Type III 24-hr 10-year Rainfall=4.70"

Printed 11/5/2021

Page 43

Summary for Subcatchment 6S: Sub 6

Runoff = 0.01 cfs @ 13.78 hrs, Volume= 224 cf, Depth= 0.14"

Routed to Link 3L : Spofford Pond Wetlands

Runoff by SCS TR-20 method, UH=SCS, Weighted-CN, Time Span= 1.00-36.00 hrs, dt= 0.01 hrs
Type III 24-hr 10-year Rainfall=4.70"

	Area (sf)	CN	Description
*	8,202	30	Grass
	7,952	30	Woods, Good, HSG A
	2,600	98	Paved parking, HSG A
	18,754	39	Weighted Average
	16,154		86.14% Pervious Area
	2,600		13.86% Impervious Area

Tc (min)	Length (feet)	Slope (ft/ft)	Velocity (ft/sec)	Capacity (cfs)	Description
6.0					Direct Entry,

Subcatchment 6S: Sub 6

Hydrograph

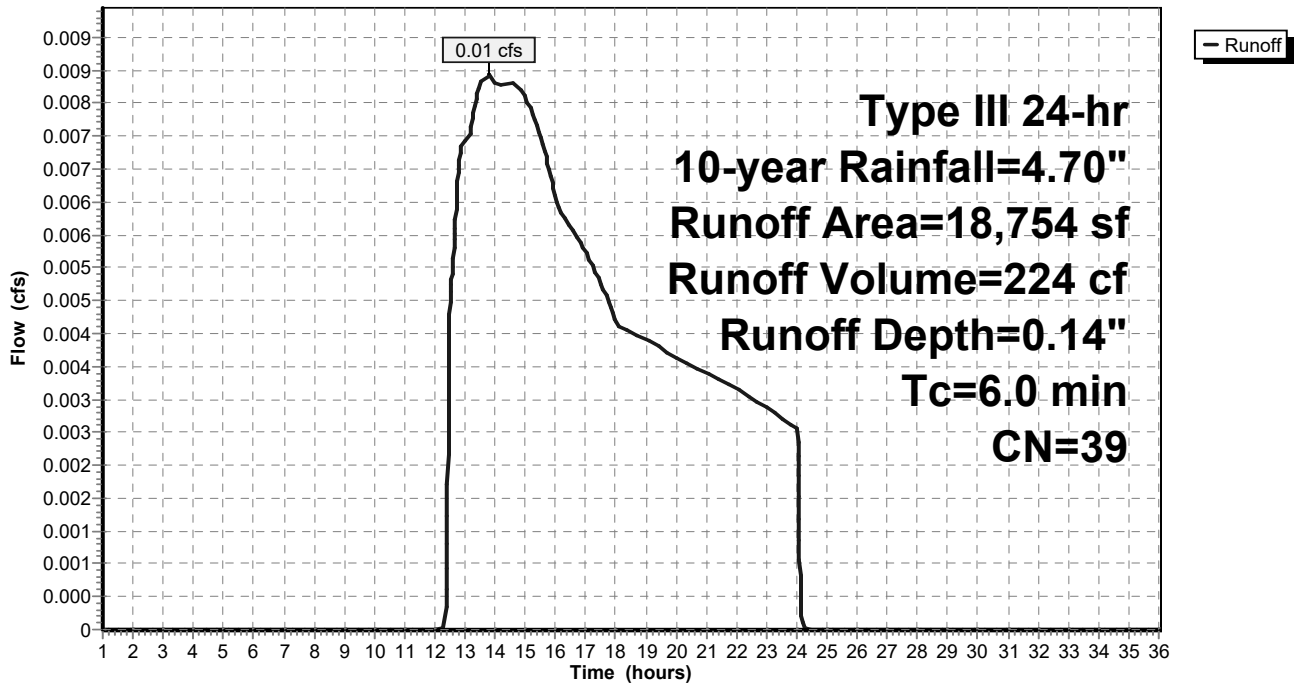

Spofford Post-Development

Prepared by Weston & Sampson

HydroCAD® 10.10-6a s/n 00455 © 2020 HydroCAD Software Solutions LLC

Type III 24-hr 10-year Rainfall=4.70"

Printed 11/5/2021

Page 44

Summary for Subcatchment 7S: Sub 7

Runoff = 0.49 cfs @ 12.08 hrs, Volume= 1,739 cf, Depth> 4.46"
Routed to Pond 4P : Detention Chambers sC 740

Runoff by SCS TR-20 method, UH=SCS, Weighted-CN, Time Span= 1.00-36.00 hrs, dt= 0.01 hrs
Type III 24-hr 10-year Rainfall=4.70"

Area (sf)	CN	Description
4,674	98	Paved parking, HSG A
4,674		100.00% Impervious Area

Tc (min)	Length (feet)	Slope (ft/ft)	Velocity (ft/sec)	Capacity (cfs)	Description
6.0					Direct Entry,

Subcatchment 7S: Sub 7

Hydrograph

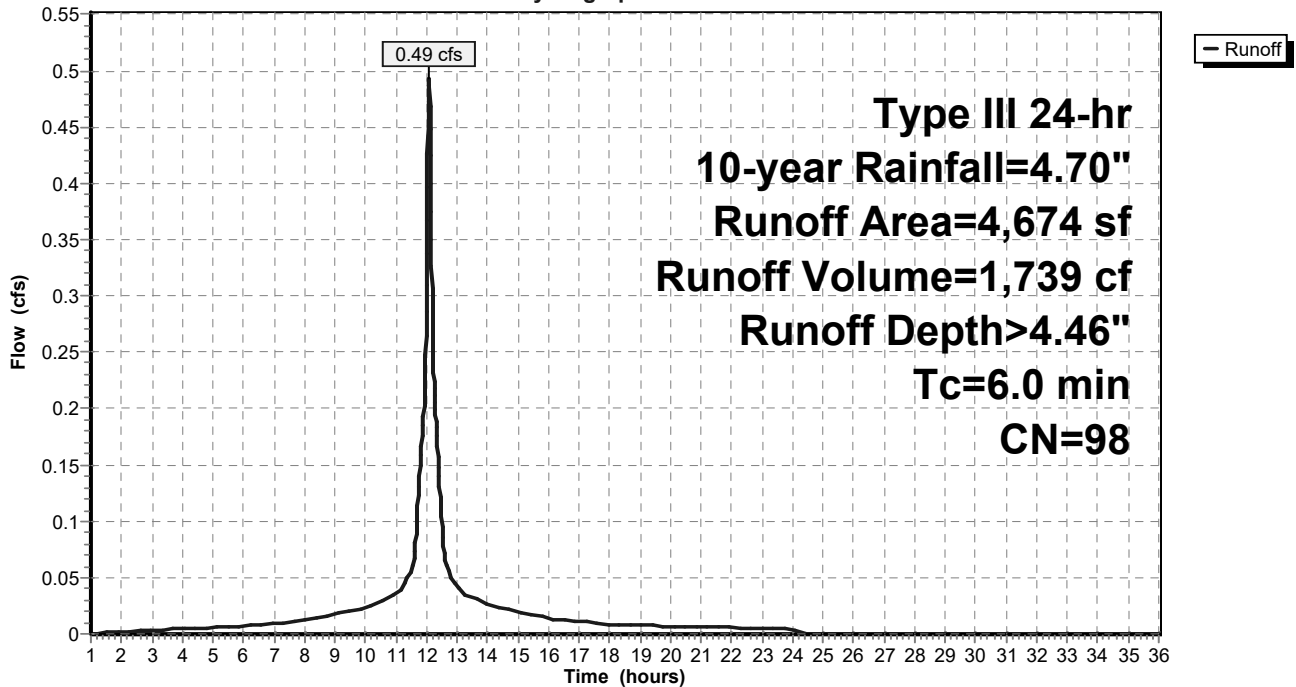

Spofford Post-Development

Prepared by Weston & Sampson

HydroCAD® 10.10-6a s/n 00455 © 2020 HydroCAD Software Solutions LLC

Type III 24-hr 10-year Rainfall=4.70"

Printed 11/5/2021

Page 45

Summary for Subcatchment 8S: Sub 8

Runoff = 0.00 cfs @ 24.02 hrs, Volume= 0 cf, Depth= 0.00"

Routed to Link 3L : Spofford Pond Wetlands

Runoff by SCS TR-20 method, UH=SCS, Weighted-CN, Time Span= 1.00-36.00 hrs, dt= 0.01 hrs
Type III 24-hr 10-year Rainfall=4.70"

Area (sf)	CN	Description
* 23,822	30	Grass
23,822		100.00% Pervious Area

Tc (min)	Length (feet)	Slope (ft/ft)	Velocity (ft/sec)	Capacity (cfs)	Description
6.0					Direct Entry,

Subcatchment 8S: Sub 8

Hydrograph

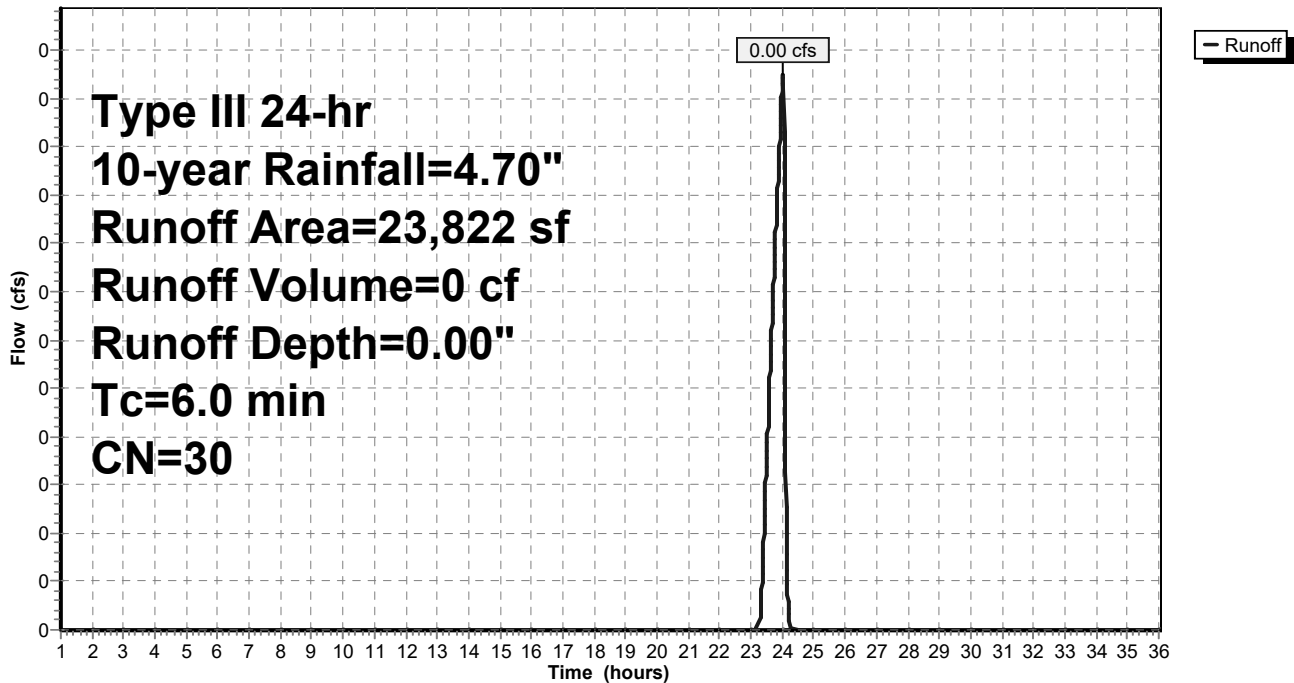

Spofford Post-Development

Prepared by Weston & Sampson

HydroCAD® 10.10-6a s/n 00455 © 2020 HydroCAD Software Solutions LLC

Type III 24-hr 10-year Rainfall=4.70"

Printed 11/5/2021

Page 46

Summary for Subcatchment 9S: Sub 9

Runoff = 0.96 cfs @ 12.08 hrs, Volume= 3,222 cf, Depth= 4.12"
 Routed to Pond 4P : Detention Chambers sC 740

Runoff by SCS TR-20 method, UH=SCS, Weighted-CN, Time Span= 1.00-36.00 hrs, dt= 0.01 hrs
 Type III 24-hr 10-year Rainfall=4.70"

Area (sf)	CN	Description
8,974	98	Paved parking, HSG A
* 405	30	Grass
9,379	95	Weighted Average
405		4.32% Pervious Area
8,974		95.68% Impervious Area

Tc (min)	Length (feet)	Slope (ft/ft)	Velocity (ft/sec)	Capacity (cfs)	Description
6.0					Direct Entry,

Subcatchment 9S: Sub 9

Hydrograph

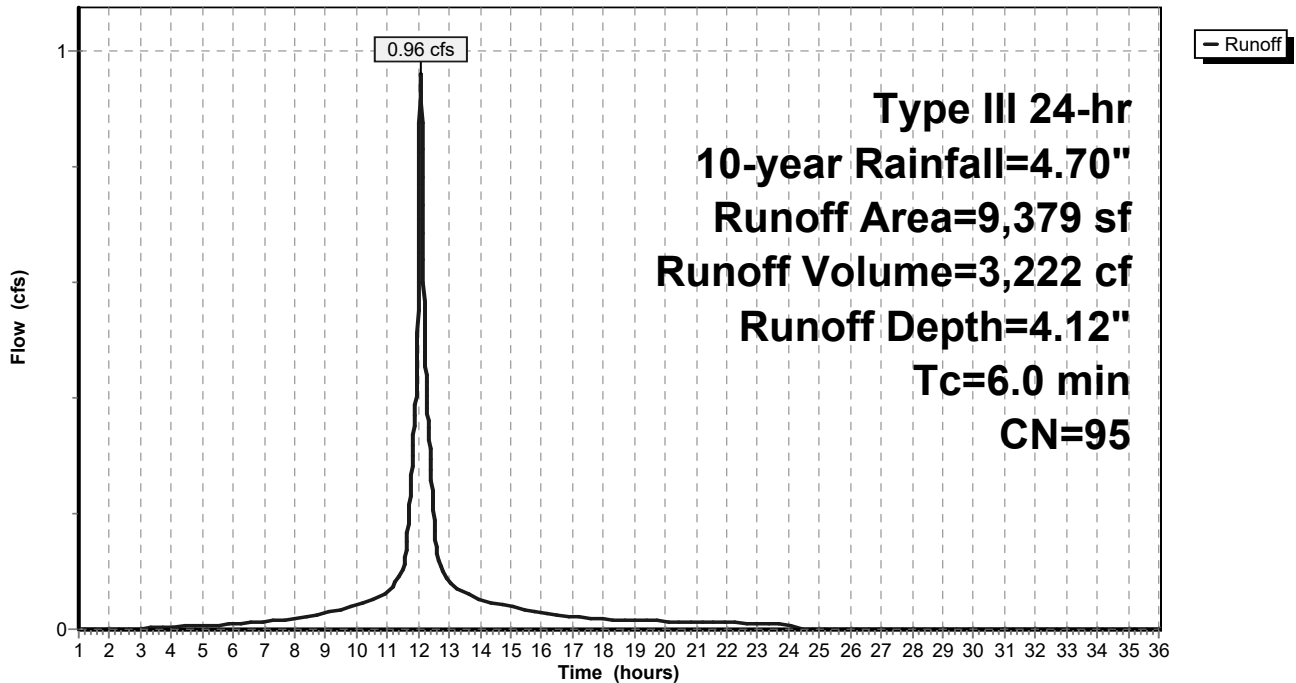

Spofford Post-Development

Prepared by Weston & Sampson

HydroCAD® 10.10-6a s/n 00455 © 2020 HydroCAD Software Solutions LLC

Type III 24-hr 10-year Rainfall=4.70"

Printed 11/5/2021

Page 47

Summary for Subcatchment 10S: Sub 10

Runoff = 1.18 cfs @ 12.09 hrs, Volume= 3,666 cf, Depth= 2.37"
 Routed to Pond 4P : Detention Chambers sC 740

Runoff by SCS TR-20 method, UH=SCS, Weighted-CN, Time Span= 1.00-36.00 hrs, dt= 0.01 hrs
 Type III 24-hr 10-year Rainfall=4.70"

Area (sf)	CN	Description
12,796	98	Paved parking, HSG A
424	30	Woods, Good, HSG A
* 5,312	30	Grass
18,532	77	Weighted Average
5,736		30.95% Pervious Area
12,796		69.05% Impervious Area

Tc (min)	Length (feet)	Slope (ft/ft)	Velocity (ft/sec)	Capacity (cfs)	Description
6.0					Direct Entry,

Subcatchment 10S: Sub 10

Hydrograph

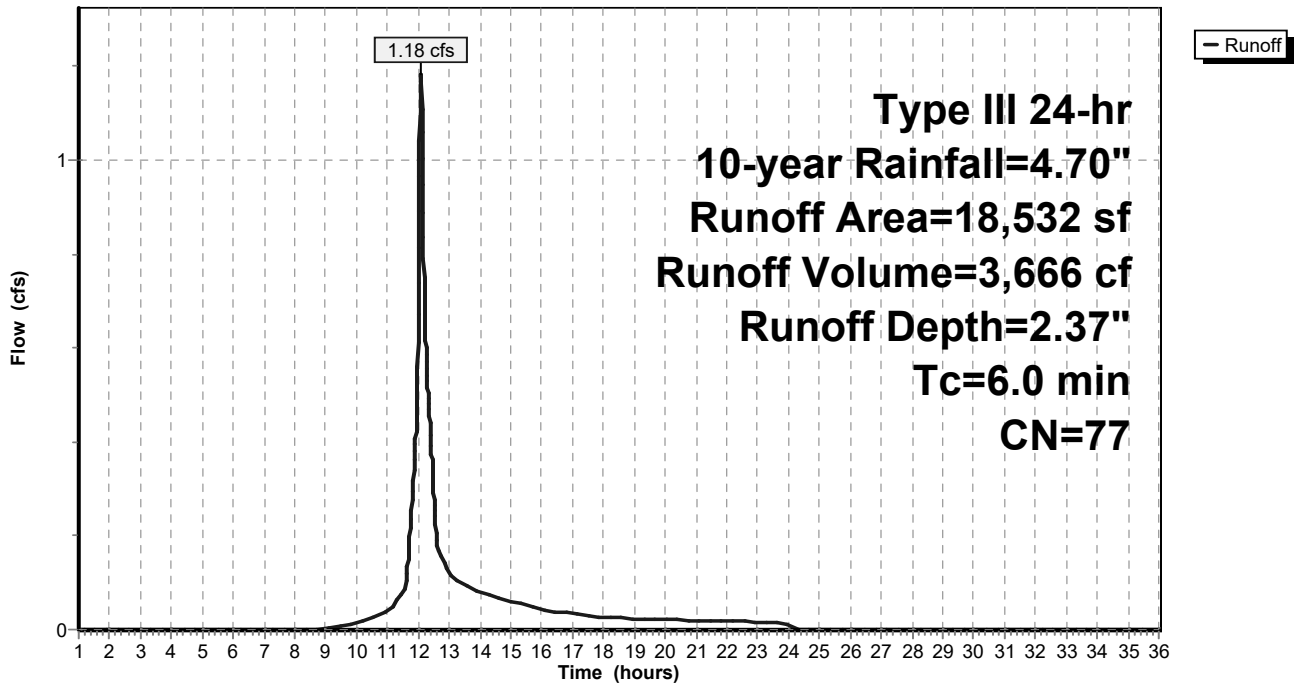

Spofford Post-Development

Prepared by Weston & Sampson

HydroCAD® 10.10-6a s/n 00455 © 2020 HydroCAD Software Solutions LLC

Type III 24-hr 10-year Rainfall=4.70"

Printed 11/5/2021

Page 48

Summary for Subcatchment 11S: Sub 11

Runoff = 0.71 cfs @ 12.08 hrs, Volume= 2,467 cf, Depth= 4.35"
Routed to Pond 4P : Detention Chambers sC 740

Runoff by SCS TR-20 method, UH=SCS, Weighted-CN, Time Span= 1.00-36.00 hrs, dt= 0.01 hrs
Type III 24-hr 10-year Rainfall=4.70"

Area (sf)	CN	Description
6,701	98	Paved parking, HSG A
* 107	30	Grass
6,808	97	Weighted Average
107		1.57% Pervious Area
6,701		98.43% Impervious Area

Tc (min)	Length (feet)	Slope (ft/ft)	Velocity (ft/sec)	Capacity (cfs)	Description
6.0					Direct Entry,

Subcatchment 11S: Sub 11

Hydrograph

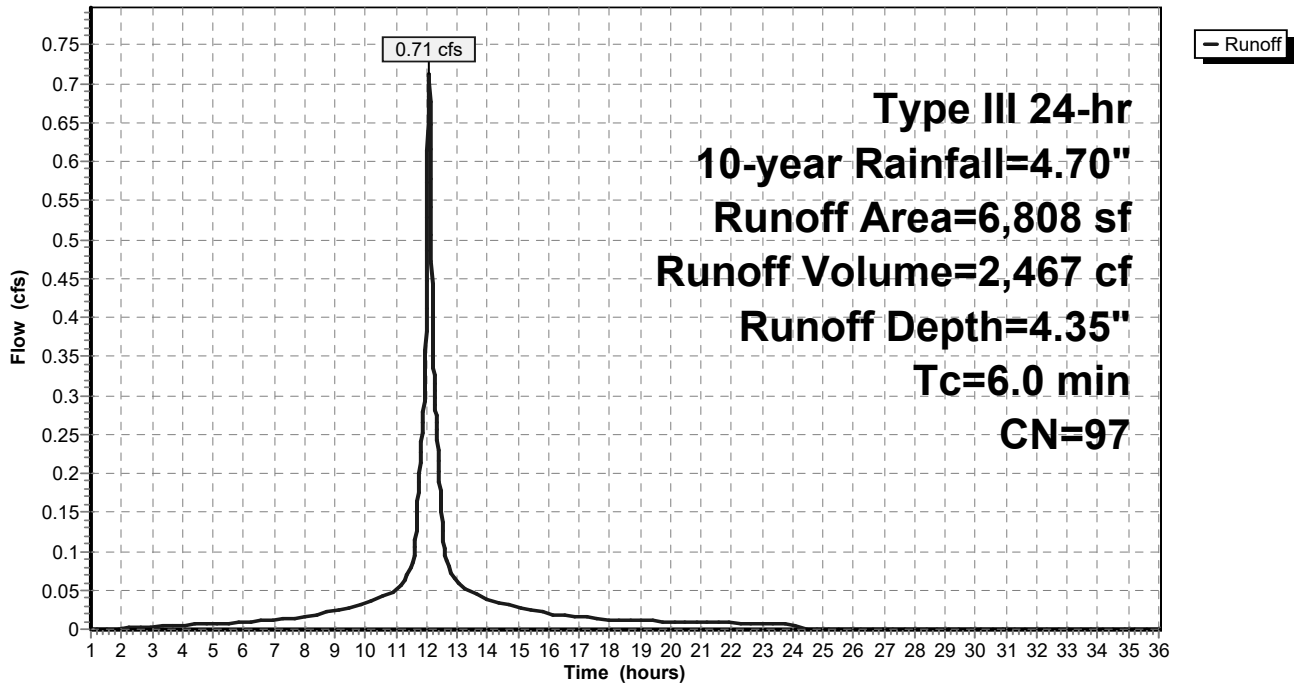

Spofford Post-Development

Prepared by Weston & Sampson

HydroCAD® 10.10-6a s/n 00455 © 2020 HydroCAD Software Solutions LLC

Type III 24-hr 10-year Rainfall=4.70"

Printed 11/5/2021

Page 49

Summary for Subcatchment 12S: Sub 12

Runoff = 0.00 cfs @ 24.02 hrs, Volume= 0 cf, Depth= 0.00"
Routed to Link 2L : Isolated Wetlands

Runoff by SCS TR-20 method, UH=SCS, Weighted-CN, Time Span= 1.00-36.00 hrs, dt= 0.01 hrs
Type III 24-hr 10-year Rainfall=4.70"

	Area (sf)	CN	Description
*	5,470	30	Grass
	5,470		100.00% Pervious Area

Tc (min)	Length (feet)	Slope (ft/ft)	Velocity (ft/sec)	Capacity (cfs)	Description
6.0					Direct Entry,

Subcatchment 12S: Sub 12

Hydrograph

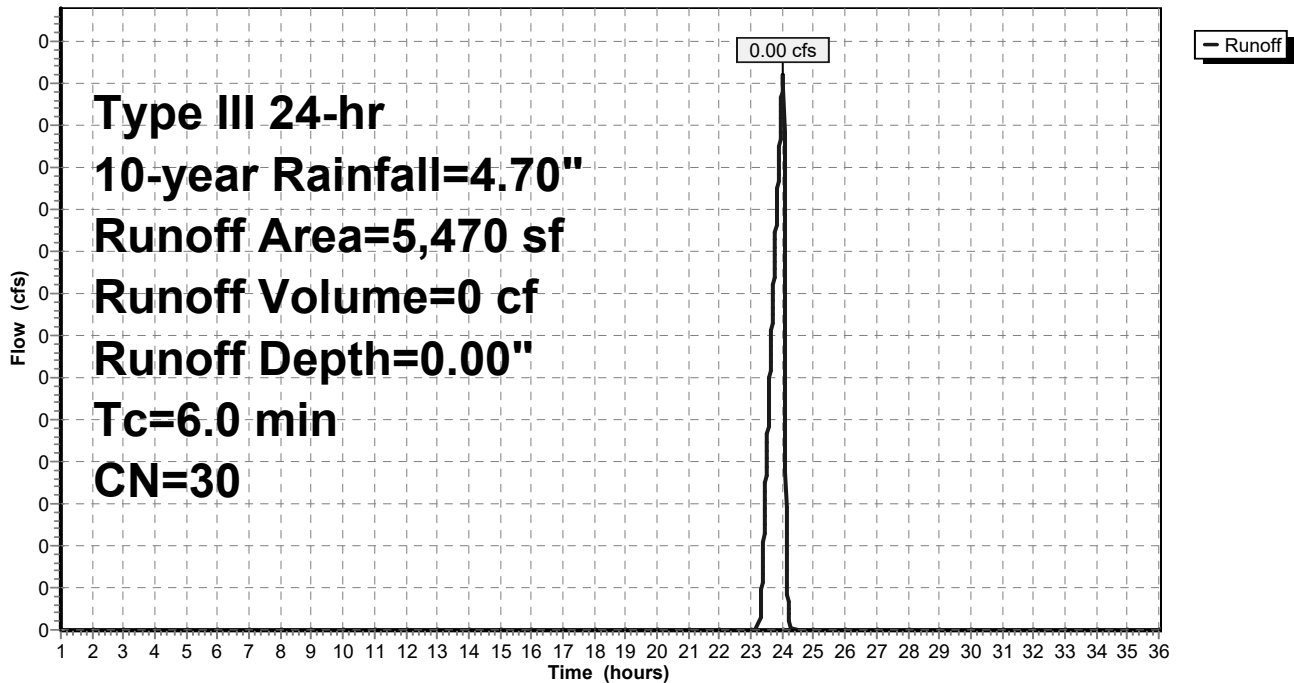

Spofford Post-Development

Prepared by Weston & Sampson

HydroCAD® 10.10-6a s/n 00455 © 2020 HydroCAD Software Solutions LLC

Type III 24-hr 10-year Rainfall=4.70"

Printed 11/5/2021

Page 50

Summary for Subcatchment 13S: Sub 13

Runoff = 0.31 cfs @ 12.09 hrs, Volume= 992 cf, Depth= 3.59"
 Routed to Pond 4P : Detention Chambers sC 740

Runoff by SCS TR-20 method, UH=SCS, Weighted-CN, Time Span= 1.00-36.00 hrs, dt= 0.01 hrs
 Type III 24-hr 10-year Rainfall=4.70"

Area (sf)	CN	Description
2,910	98	Paved parking, HSG A
* 408	30	Grass
3,318	90	Weighted Average
408		12.30% Pervious Area
2,910		87.70% Impervious Area

Tc (min)	Length (feet)	Slope (ft/ft)	Velocity (ft/sec)	Capacity (cfs)	Description
6.0					Direct Entry,

Subcatchment 13S: Sub 13

Hydrograph

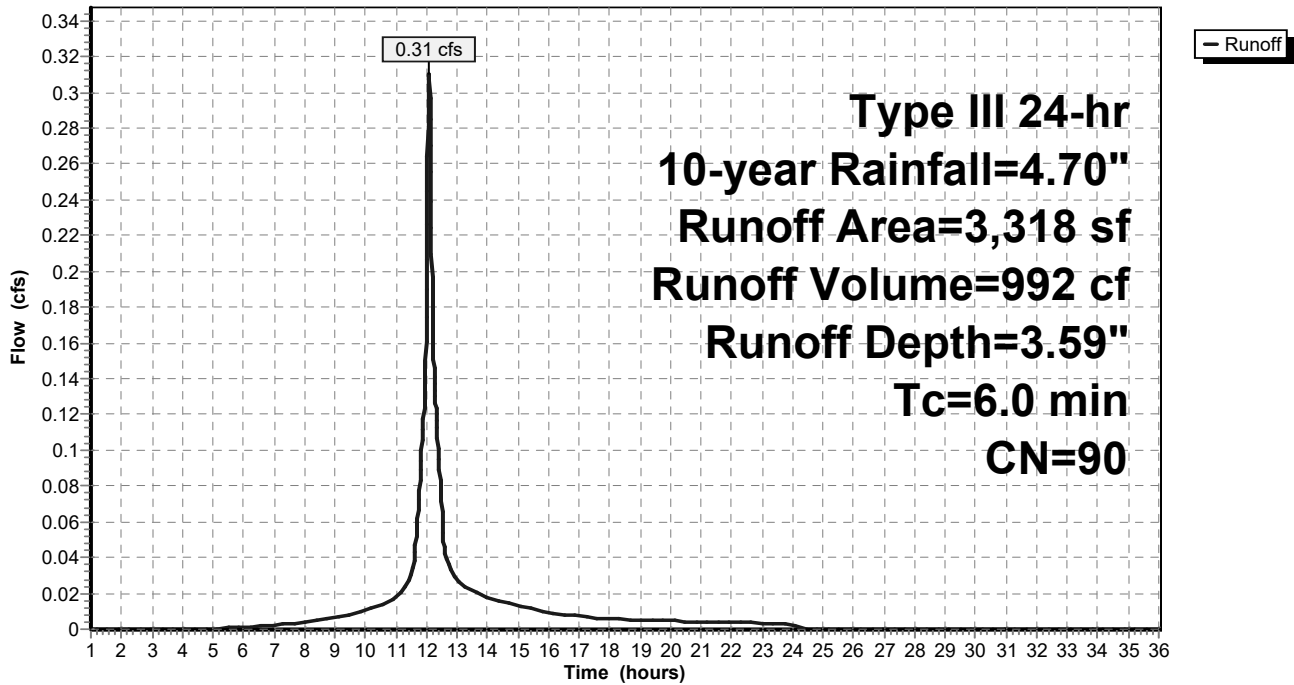

Spofford Post-Development

Prepared by Weston & Sampson

HydroCAD® 10.10-6a s/n 00455 © 2020 HydroCAD Software Solutions LLC

Type III 24-hr 10-year Rainfall=4.70"

Printed 11/5/2021

Page 51

Summary for Subcatchment 14S: Sub 14

Runoff = 0.40 cfs @ 12.08 hrs, Volume= 1,339 cf, Depth= 4.12"
 Routed to Pond 4P : Detention Chambers sC 740

Runoff by SCS TR-20 method, UH=SCS, Weighted-CN, Time Span= 1.00-36.00 hrs, dt= 0.01 hrs
 Type III 24-hr 10-year Rainfall=4.70"

Area (sf)	CN	Description
3,743	98	Paved parking, HSG A
* 155	30	Grass
3,898	95	Weighted Average
155		3.98% Pervious Area
3,743		96.02% Impervious Area

Tc (min)	Length (feet)	Slope (ft/ft)	Velocity (ft/sec)	Capacity (cfs)	Description
6.0					Direct Entry,

Subcatchment 14S: Sub 14

Hydrograph

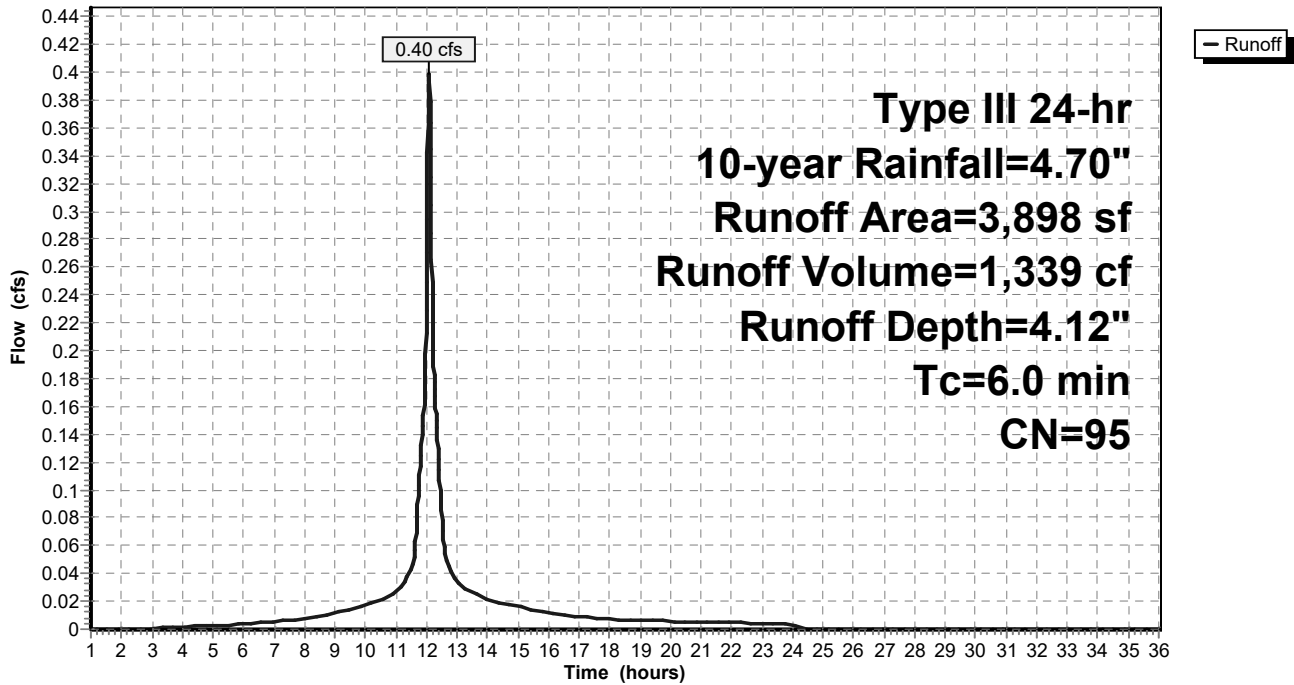

Spofford Post-Development

Prepared by Weston & Sampson

HydroCAD® 10.10-6a s/n 00455 © 2020 HydroCAD Software Solutions LLC

Type III 24-hr 10-year Rainfall=4.70"

Printed 11/5/2021

Page 52

Summary for Subcatchment 15S: Sub 15

Runoff = 4.80 cfs @ 12.08 hrs, Volume= 16,369 cf, Depth= 4.23"

Routed to Pond 3P : Sediment Forebay

Runoff by SCS TR-20 method, UH=SCS, Weighted-CN, Time Span= 1.00-36.00 hrs, dt= 0.01 hrs
 Type III 24-hr 10-year Rainfall=4.70"

	Area (sf)	CN	Description
*	1,568	30	Grass
	44,820	98	Paved parking, HSG A
	46,388	96	Weighted Average
	1,568		3.38% Pervious Area
	44,820		96.62% Impervious Area

Tc (min)	Length (feet)	Slope (ft/ft)	Velocity (ft/sec)	Capacity (cfs)	Description
6.0					Direct Entry,

Subcatchment 15S: Sub 15

Hydrograph

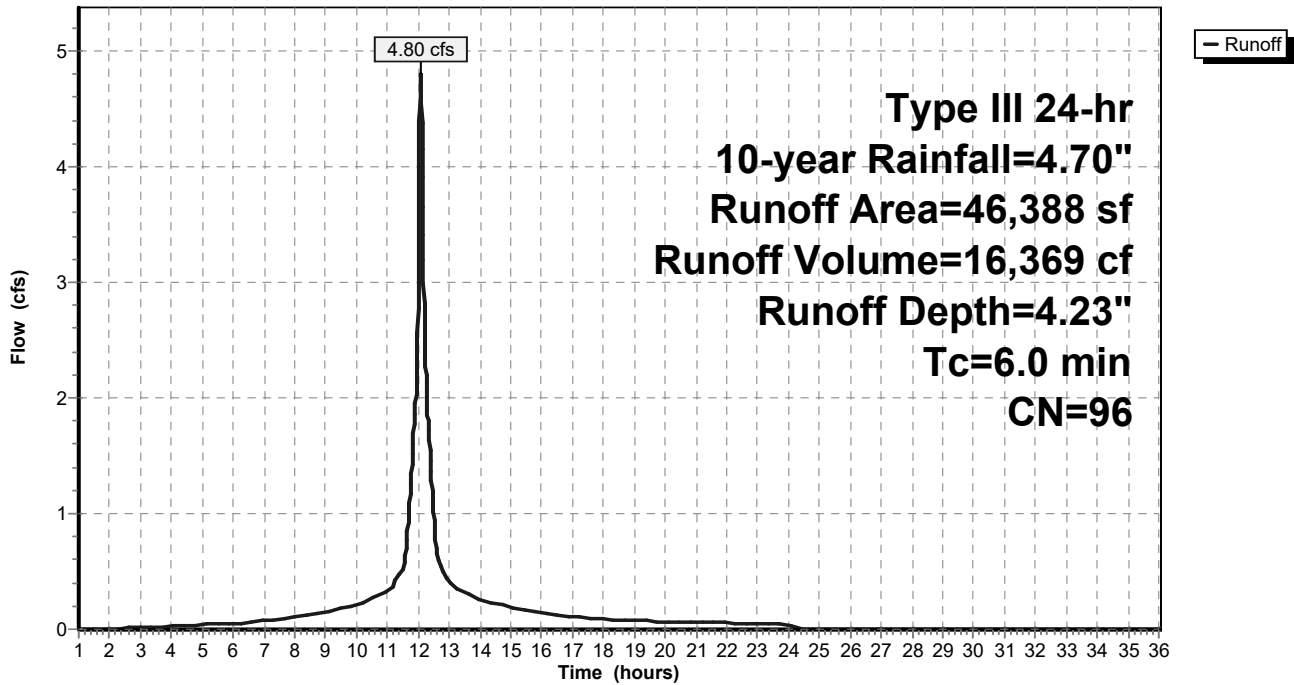

Spofford Post-Development

Prepared by Weston & Sampson

HydroCAD® 10.10-6a s/n 00455 © 2020 HydroCAD Software Solutions LLC

Type III 24-hr 10-year Rainfall=4.70"

Printed 11/5/2021

Page 53

Summary for Subcatchment 16S: Sub 16

Runoff = 1.11 cfs @ 12.08 hrs, Volume= 3,651 cf, Depth= 3.90"
 Routed to Pond 4P : Detention Chambers sC 740

Runoff by SCS TR-20 method, UH=SCS, Weighted-CN, Time Span= 1.00-36.00 hrs, dt= 0.01 hrs
 Type III 24-hr 10-year Rainfall=4.70"

Area (sf)	CN	Description
10,400	98	Paved parking, HSG A
* 822	30	Grass
11,222	93	Weighted Average
822		7.32% Pervious Area
10,400		92.68% Impervious Area

Tc (min)	Length (feet)	Slope (ft/ft)	Velocity (ft/sec)	Capacity (cfs)	Description
6.0					Direct Entry,

Subcatchment 16S: Sub 16

Hydrograph

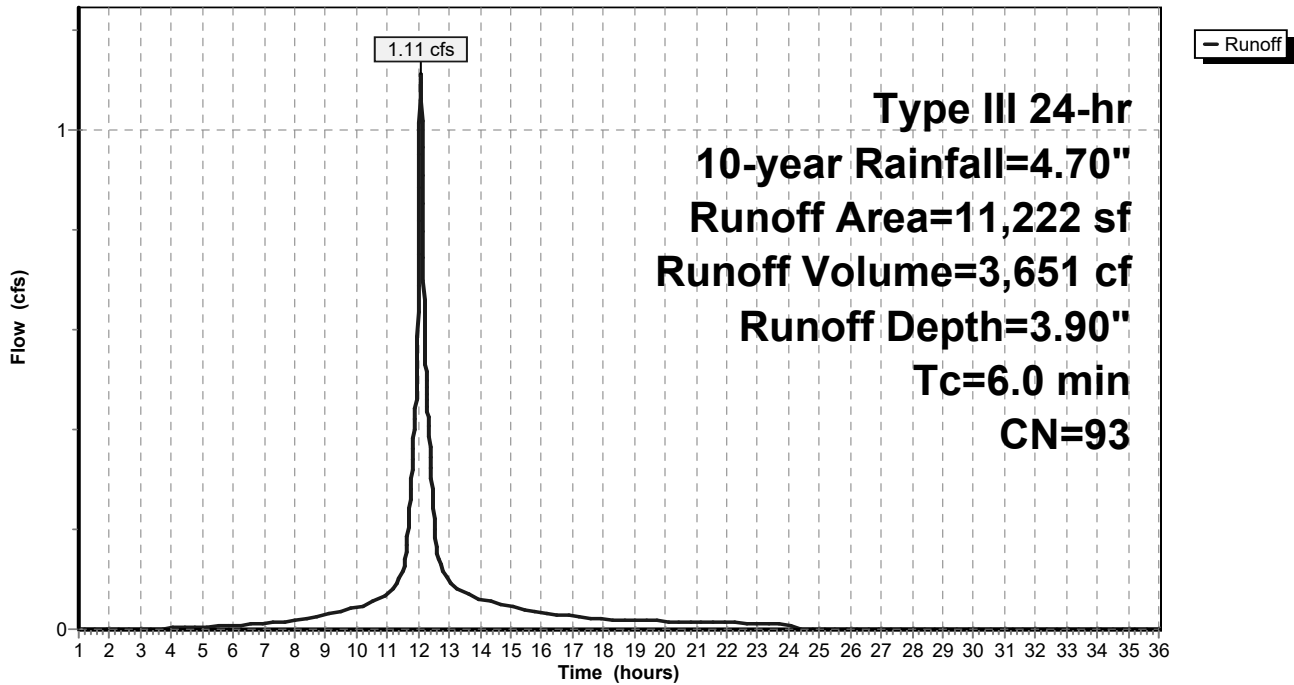

Spofford Post-Development

Prepared by Weston & Sampson

HydroCAD® 10.10-6a s/n 00455 © 2020 HydroCAD Software Solutions LLC

Type III 24-hr 10-year Rainfall=4.70"

Printed 11/5/2021

Page 54

Summary for Subcatchment 17S: Sub 17

Runoff = 1.14 cfs @ 12.08 hrs, Volume= 3,932 cf, Depth= 4.35"
Routed to Pond 4P : Detention Chambers sC 740

Runoff by SCS TR-20 method, UH=SCS, Weighted-CN, Time Span= 1.00-36.00 hrs, dt= 0.01 hrs
Type III 24-hr 10-year Rainfall=4.70"

Area (sf)	CN	Description
* 155	30	Grass
10,696	98	Paved parking, HSG A
10,851	97	Weighted Average
155		1.43% Pervious Area
10,696		98.57% Impervious Area

Tc (min)	Length (feet)	Slope (ft/ft)	Velocity (ft/sec)	Capacity (cfs)	Description
6.0					Direct Entry,

Subcatchment 17S: Sub 17

Hydrograph

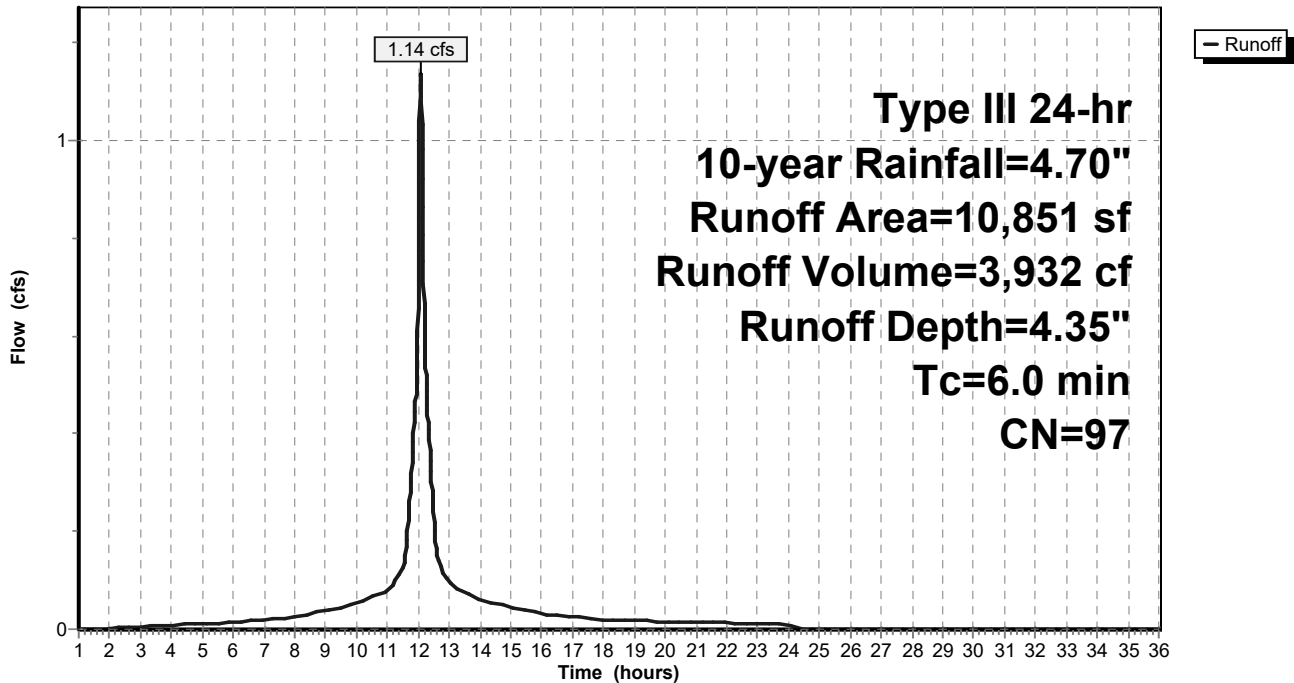

Spofford Post-Development

Prepared by Weston & Sampson

HydroCAD® 10.10-6a s/n 00455 © 2020 HydroCAD Software Solutions LLC

Type III 24-hr 10-year Rainfall=4.70"

Printed 11/5/2021

Page 56

Summary for Subcatchment 19S: Sub 19

Runoff = 0.00 cfs @ 24.02 hrs, Volume= 0 cf, Depth= 0.00"

Routed to Link 2L : Isolated Wetlands

Runoff by SCS TR-20 method, UH=SCS, Weighted-CN, Time Span= 1.00-36.00 hrs, dt= 0.01 hrs
Type III 24-hr 10-year Rainfall=4.70"

Area (sf)	CN	Description
* 3,953	30	Grass
3,953		100.00% Pervious Area

Tc (min)	Length (feet)	Slope (ft/ft)	Velocity (ft/sec)	Capacity (cfs)	Description
6.0					Direct Entry,

Subcatchment 19S: Sub 19

Hydrograph

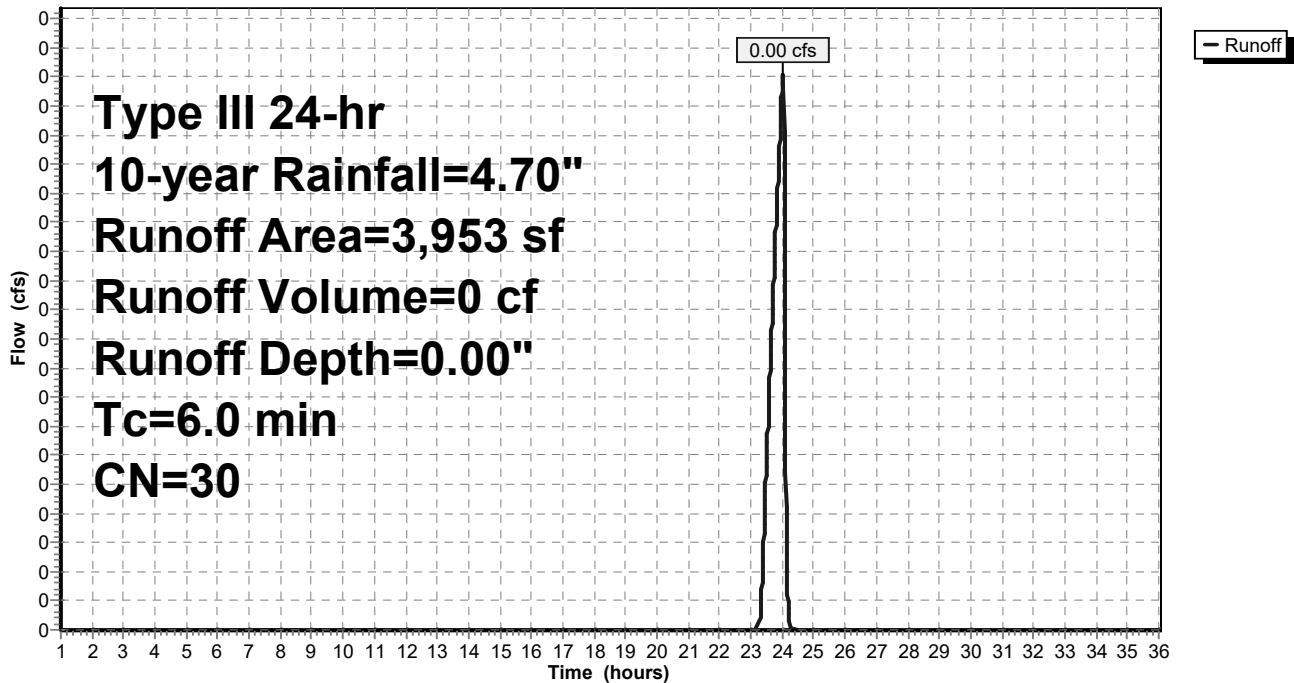

Spofford Post-Development

Prepared by Weston & Sampson

HydroCAD® 10.10-6a s/n 00455 © 2020 HydroCAD Software Solutions LLC

Type III 24-hr 10-year Rainfall=4.70"

Printed 11/5/2021

Page 57

Summary for Pond 3P: Sediment Forebay

Inflow Area = 46,388 sf, 96.62% Impervious, Inflow Depth = 4.23" for 10-year event
 Inflow = 4.80 cfs @ 12.08 hrs, Volume= 16,369 cf
 Outflow = 4.70 cfs @ 12.10 hrs, Volume= 15,995 cf, Atten= 2%, Lag= 1.0 min
 Primary = 4.70 cfs @ 12.10 hrs, Volume= 15,995 cf
 Routed to Pond 4P : Detention Chambers sC 740
 Secondary = 0.00 cfs @ 1.00 hrs, Volume= 0 cf
 Routed to Pond 4P : Detention Chambers sC 740

Routing by Dyn-Stor-Ind method, Time Span= 1.00-36.00 hrs, dt= 0.01 hrs
 Peak Elev= 133.83' @ 12.10 hrs Surf.Area= 1,188 sf Storage= 772 cf

Plug-Flow detention time= 28.5 min calculated for 15,990 cf (98% of inflow)
 Center-of-Mass det. time= 14.2 min (778.1 - 763.9)

Volume	Invert	Avail.Storage	Storage Description
#1	133.00'	979 cf	Custom Stage Data (Irregular) Listed below (Recalc)

Elevation (feet)	Surf.Area (sq-ft)	Perim. (feet)	Inc.Store (cubic-feet)	Cum.Store (cubic-feet)	Wet.Area (sq-ft)
133.00	687	186.0	0	0	687
134.00	1,304	215.0	979	979	1,634

Device	Routing	Invert	Outlet Devices
#1	Primary	128.65'	24.0" Round Culvert L= 29.0' CPP, projecting, no headwall, Ke= 0.900 Inlet / Outlet Invert= 128.65' / 128.50' S= 0.0052 '/' Cc= 0.900 n= 0.013 Corrugated PE, smooth interior, Flow Area= 3.14 sf
#2	Device 1	133.46'	24.0" Horiz. Orifice/Grate C= 0.600 Limited to weir flow at low heads
#3	Secondary	134.00'	215.0' long x 2.0' breadth Broad-Crested Rectangular Weir Head (feet) 0.20 0.40 0.60 0.80 1.00 1.20 1.40 1.60 1.80 2.00 2.50 3.00 3.50 Coef. (English) 2.54 2.61 2.61 2.60 2.66 2.70 2.77 2.89 2.88 2.85 3.07 3.20 3.32

Primary OutFlow Max=4.70 cfs @ 12.10 hrs HW=133.83' TW=129.36' (Dynamic Tailwater)

↑1=Culvert (Passes 4.70 cfs of 24.43 cfs potential flow)

↑2=Orifice/Grate (Weir Controls 4.70 cfs @ 2.00 fps)

Secondary OutFlow Max=0.00 cfs @ 1.00 hrs HW=133.00' TW=127.76' (Dynamic Tailwater)

↑3=Broad-Crested Rectangular Weir (Controls 0.00 cfs)

Pond 3P: Sediment Forebay

Hydrograph

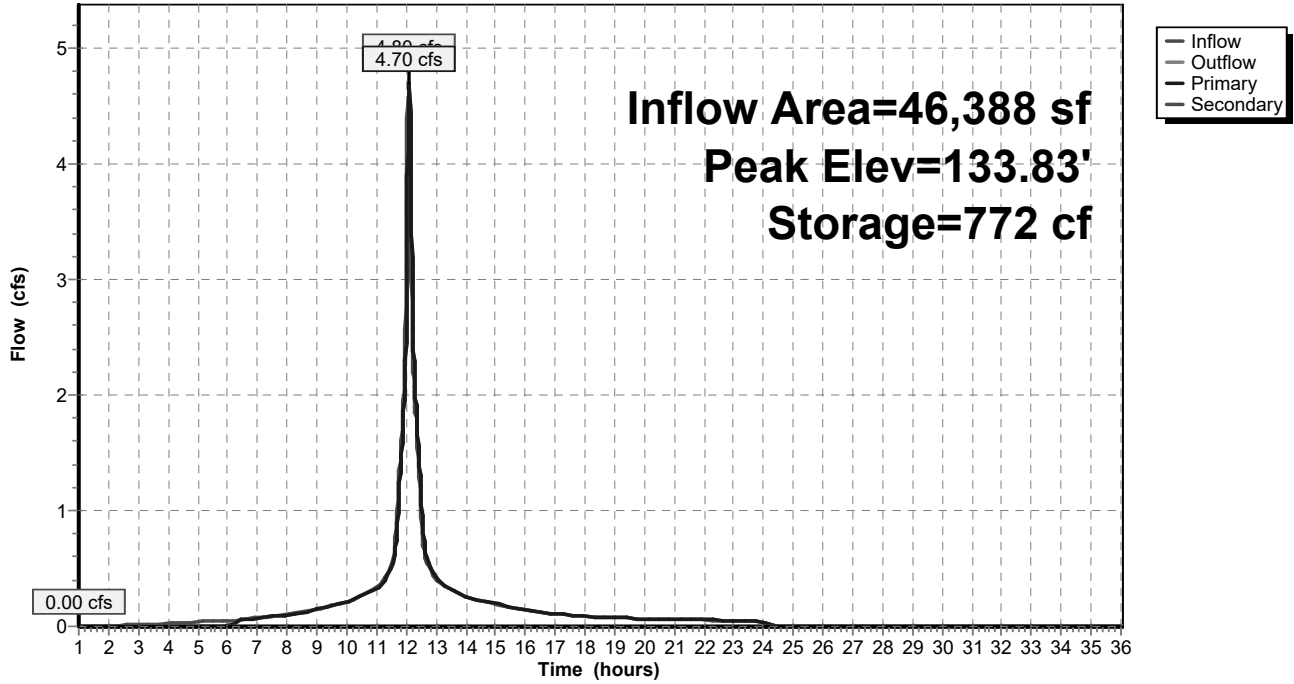

Spofford Post-Development

Prepared by Weston & Sampson

HydroCAD® 10.10-6a s/n 00455 © 2020 HydroCAD Software Solutions LLC

Type III 24-hr 10-year Rainfall=4.70"

Printed 11/5/2021

Page 59

Summary for Pond 4P: Detention Chambers sC 740

Inflow Area = 235,054 sf, 90.09% Impervious, Inflow Depth > 3.76" for 10-year event
 Inflow = 21.73 cfs @ 12.09 hrs, Volume= 73,721 cf
 Outflow = 11.53 cfs @ 12.22 hrs, Volume= 73,375 cf, Atten= 47%, Lag= 8.0 min
 Primary = 11.53 cfs @ 12.22 hrs, Volume= 73,375 cf
 Routed to Link 4L : Vernal Pool Wetlands

Routing by Dyn-Stor-Ind method, Time Span= 1.00-36.00 hrs, dt= 0.01 hrs
 Peak Elev= 129.58' @ 12.22 hrs Surf.Area= 14,134 sf Storage= 17,879 cf

Plug-Flow detention time= 88.7 min calculated for 73,375 cf (100% of inflow)
 Center-of-Mass det. time= 85.6 min (859.9 - 774.4)

Volume	Invert	Avail.Storage	Storage Description
#1A	127.76'	12,437 cf	120.25'W x 117.54'L x 3.50'H Field A 49,468 cf Overall - 18,376 cf Embedded = 31,092 cf x 40.0% Voids
#2A	128.26'	18,376 cf	ADS_StormTech SC-740 +Cap x 400 Inside #1 Effective Size= 44.6"W x 30.0"H => 6.45 sf x 7.12'L = 45.9 cf Overall Size= 51.0"W x 30.0"H x 7.56'L with 0.44' Overlap 400 Chambers in 25 Rows
		30,813 cf	Total Available Storage

Storage Group A created with Chamber Wizard

Device	Routing	Invert	Outlet Devices
#1	Primary	127.66'	24.0" Round Culvert L= 92.0' CPP, projecting, no headwall, Ke= 0.900 Inlet / Outlet Invert= 127.66' / 127.15' S= 0.0055 '/' Cc= 0.900 n= 0.013 Corrugated PE, smooth interior, Flow Area= 3.14 sf
#2	Device 1	127.76'	4.0" Vert. Orifice/Grate C= 0.600 Limited to weir flow at low heads
#3	Device 1	128.39'	4.0' long x 0.5' breadth Broad-Crested Rectangular Weir Head (feet) 0.20 0.40 0.60 0.80 1.00 Coef. (English) 2.80 2.92 3.08 3.30 3.32

Primary OutFlow Max=11.52 cfs @ 12.22 hrs HW=129.58' TW=0.00' (Dynamic Tailwater)

- ↑ **1=Culvert** (Barrel Controls 11.52 cfs @ 4.77 fps)
- ↑ **2=Orifice/Grate** (Passes < 0.54 cfs potential flow)
- ↑ **3=Broad-Crested Rectangular Weir**(Passes < 17.18 cfs potential flow)

Pond 4P: Detention Chambers sC 740

Hydrograph

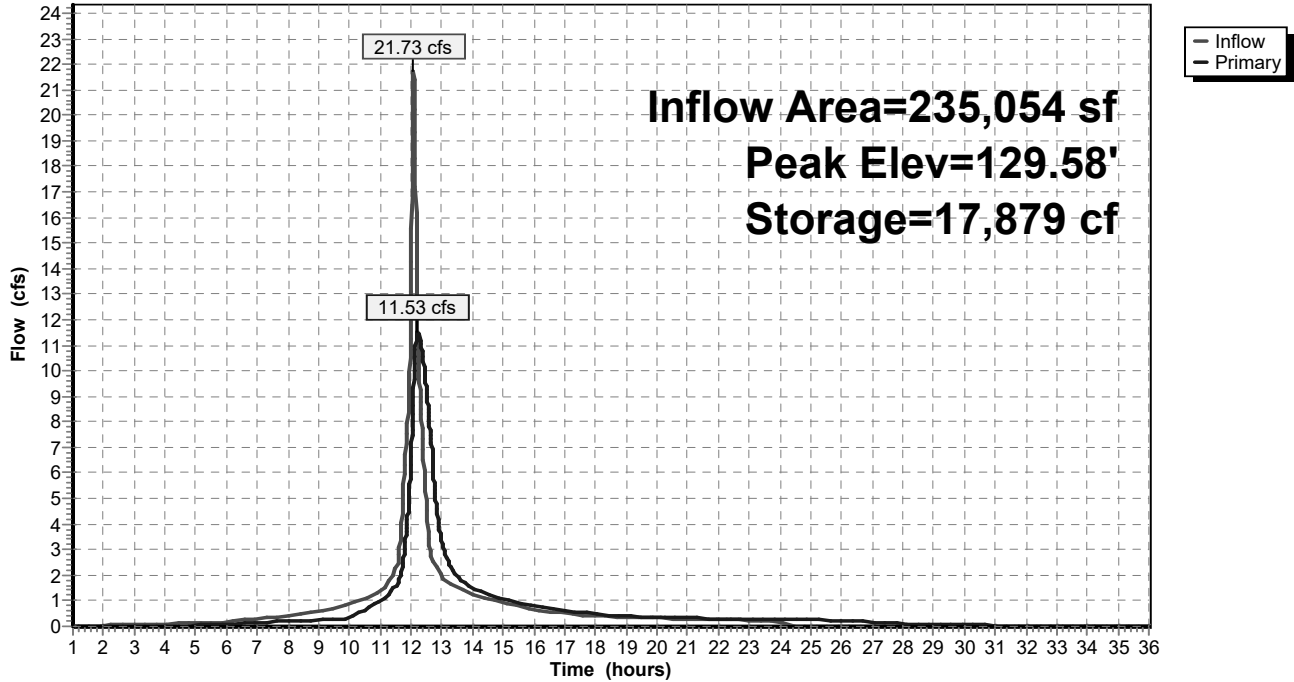

Spofford Post-Development

Prepared by Weston & Sampson

HydroCAD® 10.10-6a s/n 00455 © 2020 HydroCAD Software Solutions LLC

Type III 24-hr 10-year Rainfall=4.70"

Printed 11/5/2021

Page 61

Summary for Link 1L: Leaching CB

Inflow Area = 9,774 sf, 0.00% Impervious, Inflow Depth = 0.00" for 10-year event
Inflow = 0.00 cfs @ 24.02 hrs, Volume= 0 cf
Primary = 0.00 cfs @ 24.02 hrs, Volume= 0 cf, Atten= 0%, Lag= 0.0 min

Primary outflow = Inflow, Time Span= 1.00-36.00 hrs, dt= 0.01 hrs

Link 1L: Leaching CB

Hydrograph

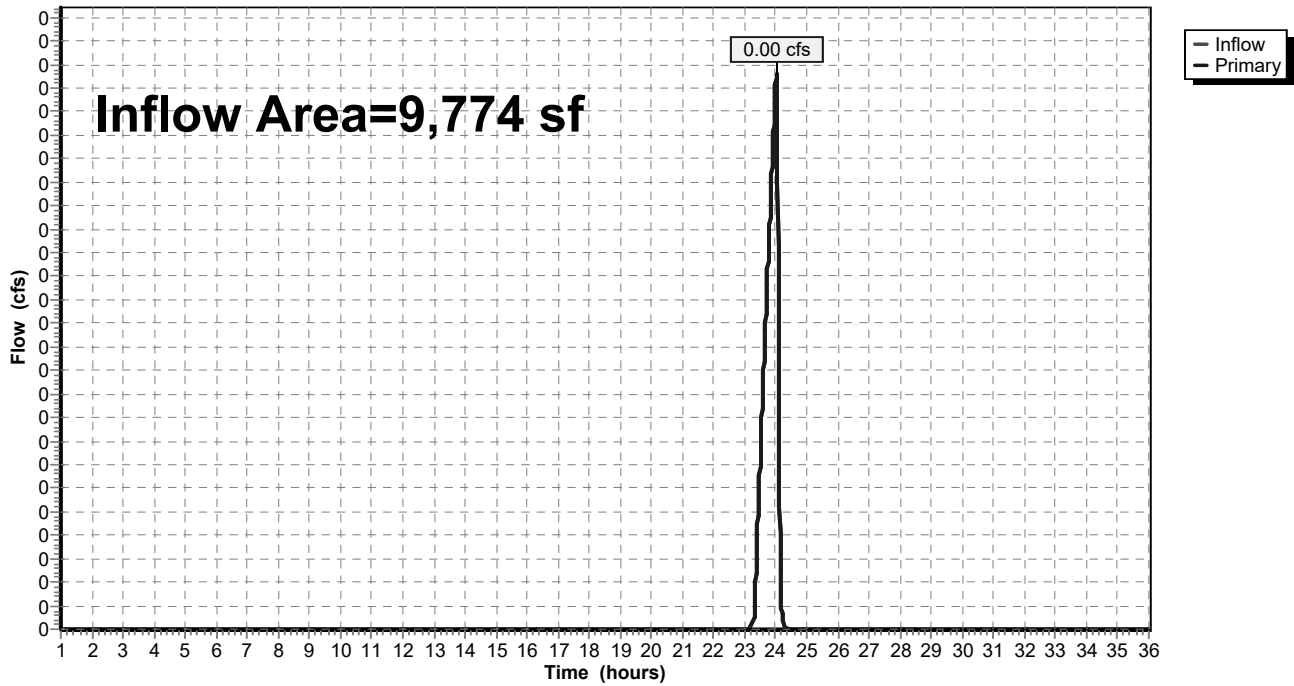

Summary for Link 2L: Isolated Wetlands

Inflow Area = 9,423 sf, 0.00% Impervious, Inflow Depth = 0.00" for 10-year event
Inflow = 0.00 cfs @ 24.02 hrs, Volume= 0 cf
Primary = 0.00 cfs @ 24.02 hrs, Volume= 0 cf, Atten= 0%, Lag= 0.0 min

Primary outflow = Inflow, Time Span= 1.00-36.00 hrs, dt= 0.01 hrs

Link 2L: Isolated Wetlands

Hydrograph

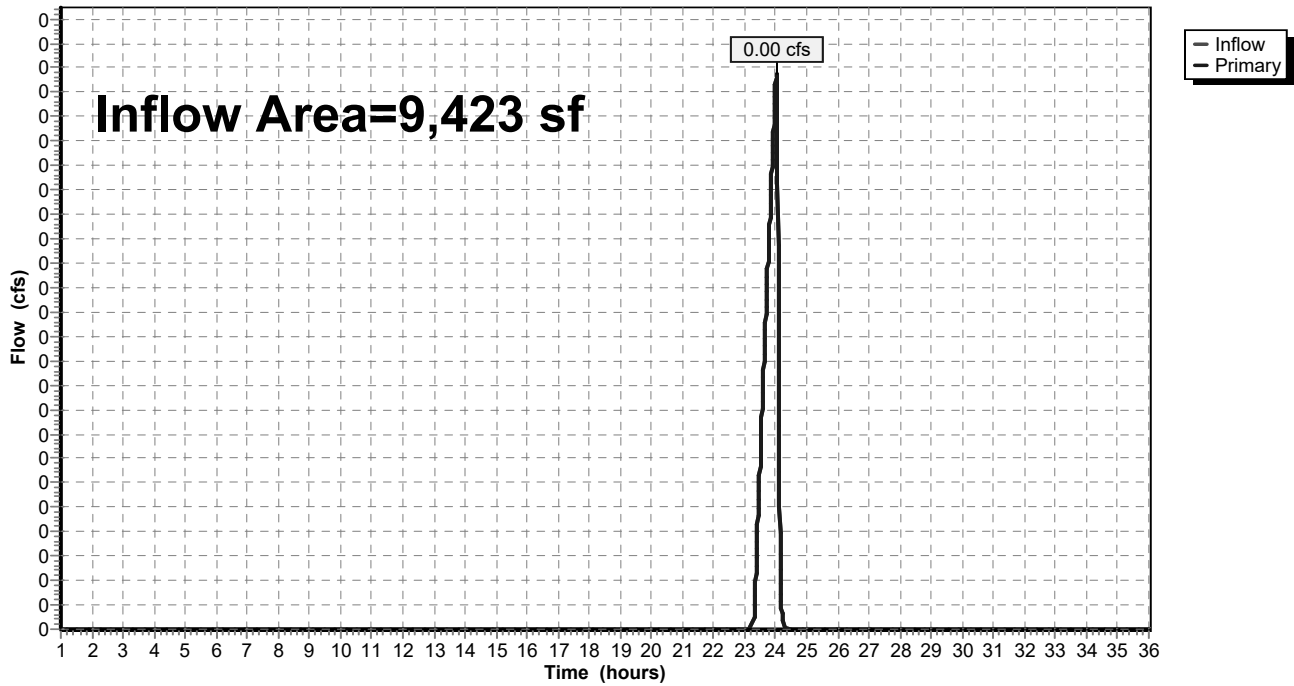

Spofford Post-Development

Prepared by Weston & Sampson

HydroCAD® 10.10-6a s/n 00455 © 2020 HydroCAD Software Solutions LLC

Type III 24-hr 10-year Rainfall=4.70"

Printed 11/5/2021

Page 63

Summary for Link 3L: Spofford Pond Wetlands

Inflow Area = 42,576 sf, 6.11% Impervious, Inflow Depth = 0.06" for 10-year event
Inflow = 0.01 cfs @ 13.78 hrs, Volume= 224 cf
Primary = 0.01 cfs @ 13.78 hrs, Volume= 224 cf, Atten= 0%, Lag= 0.0 min

Primary outflow = Inflow, Time Span= 1.00-36.00 hrs, dt= 0.01 hrs

Link 3L: Spofford Pond Wetlands

Hydrograph

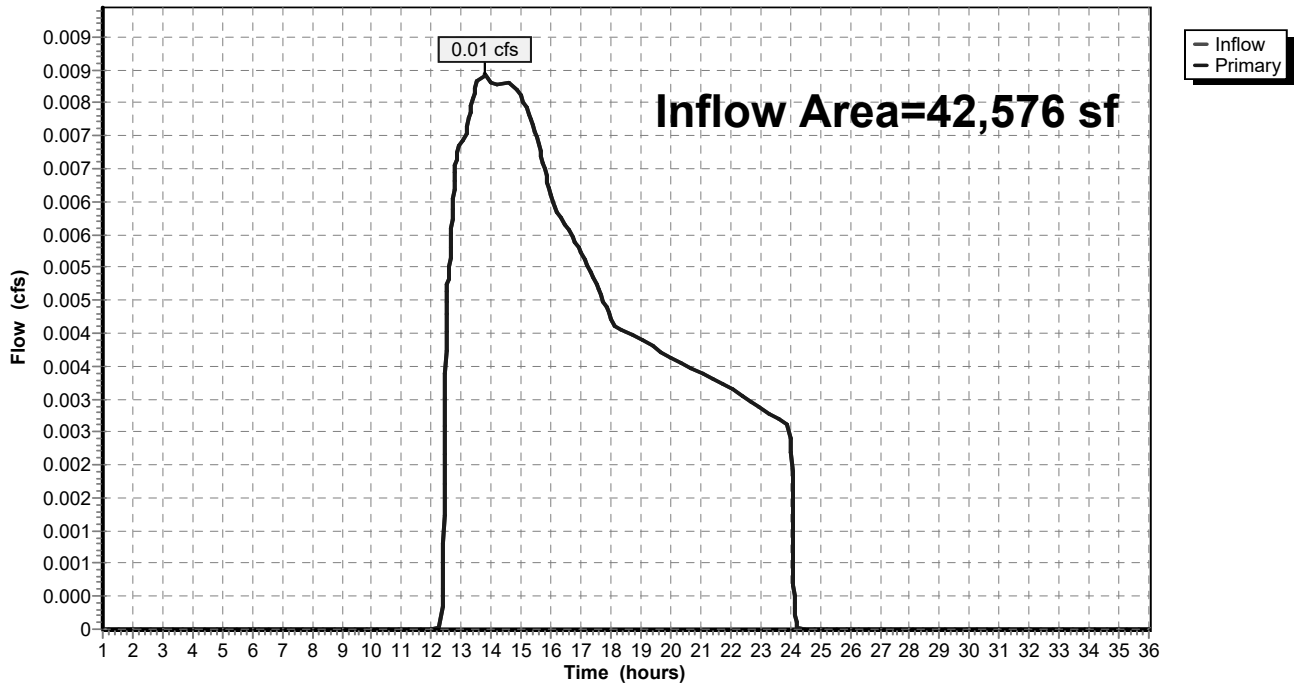

Spofford Post-Development

Prepared by Weston & Sampson

HydroCAD® 10.10-6a s/n 00455 © 2020 HydroCAD Software Solutions LLC

Type III 24-hr 10-year Rainfall=4.70"

Printed 11/5/2021

Page 64

Summary for Link 4L: Vernal Pool Wetlands

Inflow Area = 245,744 sf, 86.33% Impervious, Inflow Depth > 3.58" for 10-year event
Inflow = 11.53 cfs @ 12.22 hrs, Volume= 73,393 cf
Primary = 11.53 cfs @ 12.22 hrs, Volume= 73,393 cf, Atten= 0%, Lag= 0.0 min
Routed to nonexistent node 25L

Primary outflow = Inflow, Time Span= 1.00-36.00 hrs, dt= 0.01 hrs

Link 4L: Vernal Pool Wetlands

Hydrograph

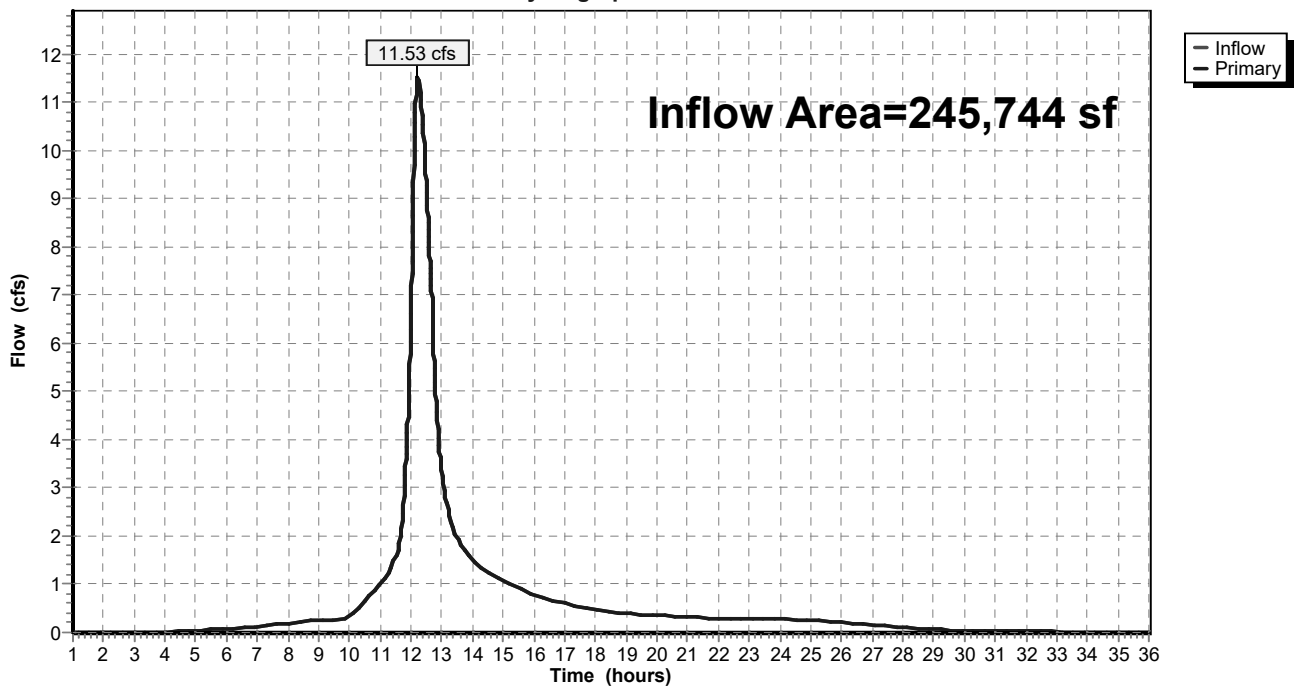

Spofford Post-Development

Prepared by Weston & Sampson

HydroCAD® 10.10-6a s/n 00455 © 2020 HydroCAD Software Solutions LLC

Type III 24-hr 25-year Rainfall=5.80"

Printed 11/5/2021

Page 65

Time span=1.00-36.00 hrs, dt=0.01 hrs, 3501 points
Runoff by SCS TR-20 method, UH=SCS, Weighted-CN
Reach routing by Dyn-Stor-Ind method - Pond routing by Dyn-Stor-Ind method

Subcatchment1S: Roof	Runoff Area=71,161 sf 100.00% Impervious Runoff Depth>5.56" Tc=6.0 min CN=98 Runoff=9.28 cfs 32,980 cf
Subcatchment2S: Sub 2	Runoff Area=9,774 sf 0.00% Impervious Runoff Depth=0.05" Tc=6.0 min CN=30 Runoff=0.00 cfs 43 cf
Subcatchment3S: Sub 3	Runoff Area=24,730 sf 73.09% Impervious Runoff Depth=3.60" Tc=6.0 min CN=80 Runoff=2.39 cfs 7,422 cf
Subcatchment4S: Sub 4	Runoff Area=13,951 sf 62.30% Impervious Runoff Depth=2.83" Tc=6.0 min CN=72 Runoff=1.06 cfs 3,291 cf
Subcatchment5S: Sub 5	Runoff Area=10,142 sf 79.94% Impervious Runoff Depth=4.01" Tc=6.0 min CN=84 Runoff=1.08 cfs 3,389 cf
Subcatchment6S: Sub 6	Runoff Area=18,754 sf 13.86% Impervious Runoff Depth=0.39" Tc=6.0 min CN=39 Runoff=0.06 cfs 609 cf
Subcatchment7S: Sub 7	Runoff Area=4,674 sf 100.00% Impervious Runoff Depth>5.56" Tc=6.0 min CN=98 Runoff=0.61 cfs 2,166 cf
Subcatchment8S: Sub 8	Runoff Area=23,822 sf 0.00% Impervious Runoff Depth=0.05" Tc=6.0 min CN=30 Runoff=0.00 cfs 104 cf
Subcatchment9S: Sub 9	Runoff Area=9,379 sf 95.68% Impervious Runoff Depth=5.21" Tc=6.0 min CN=95 Runoff=1.20 cfs 4,074 cf
Subcatchment10S: Sub 10	Runoff Area=18,532 sf 69.05% Impervious Runoff Depth=3.31" Tc=6.0 min CN=77 Runoff=1.65 cfs 5,104 cf
Subcatchment11S: Sub 11	Runoff Area=6,808 sf 98.43% Impervious Runoff Depth=5.44" Tc=6.0 min CN=97 Runoff=0.88 cfs 3,089 cf
Subcatchment12S: Sub 12	Runoff Area=5,470 sf 0.00% Impervious Runoff Depth=0.05" Tc=6.0 min CN=30 Runoff=0.00 cfs 24 cf
Subcatchment13S: Sub 13	Runoff Area=3,318 sf 87.70% Impervious Runoff Depth=4.65" Tc=6.0 min CN=90 Runoff=0.40 cfs 1,286 cf
Subcatchment14S: Sub 14	Runoff Area=3,898 sf 96.02% Impervious Runoff Depth=5.21" Tc=6.0 min CN=95 Runoff=0.50 cfs 1,693 cf
Subcatchment15S: Sub 15	Runoff Area=46,388 sf 96.62% Impervious Runoff Depth=5.33" Tc=6.0 min CN=96 Runoff=5.98 cfs 20,597 cf
Subcatchment16S: Sub 16	Runoff Area=11,222 sf 92.68% Impervious Runoff Depth=4.99" Tc=6.0 min CN=93 Runoff=1.40 cfs 4,662 cf

Spofford Post-Development

Prepared by Weston & Sampson

HydroCAD® 10.10-6a s/n 00455 © 2020 HydroCAD Software Solutions LLC

Type III 24-hr 25-year Rainfall=5.80"

Printed 11/5/2021

Page 66

Subcatchment 17S: Sub 17

Runoff Area=10,851 sf 98.57% Impervious Runoff Depth=5.44"
Tc=6.0 min CN=97 Runoff=1.41 cfs 4,923 cf

Subcatchment 18S: Sub 18

Runoff Area=10,690 sf 3.71% Impervious Runoff Depth=0.14"
Tc=6.0 min CN=33 Runoff=0.00 cfs 122 cf

Subcatchment 19S: Sub 19

Runoff Area=3,953 sf 0.00% Impervious Runoff Depth=0.05"
Tc=6.0 min CN=30 Runoff=0.00 cfs 17 cf

Pond 3P: Sediment Forebay

Peak Elev=133.89' Storage=844 cf Inflow=5.98 cfs 20,597 cf
Primary=5.85 cfs 20,223 cf Secondary=0.00 cfs 0 cf Outflow=5.85 cfs 20,223 cf

Pond 4P: Detention Chambers sC 740

Peak Elev=129.97' Storage=21,799 cf Inflow=27.62 cfs 94,303 cf
Outflow=13.65 cfs 93,944 cf

Link 1L: Leaching CB

Inflow=0.00 cfs 43 cf
Primary=0.00 cfs 43 cf

Link 2L: Isolated Wetlands

Inflow=0.00 cfs 41 cf
Primary=0.00 cfs 41 cf

Link 3L: Spofford Pond Wetlands

Inflow=0.06 cfs 713 cf
Primary=0.06 cfs 713 cf

Link 4L: Vernal Pool Wetlands

Inflow=13.65 cfs 94,066 cf
Primary=13.65 cfs 94,066 cf

Total Runoff Area = 307,517 sf Runoff Volume = 95,596 cf Average Runoff Depth = 3.73"
30.17% Pervious = 92,770 sf 69.83% Impervious = 214,747 sf

Spofford Post-Development

Prepared by Weston & Sampson

HydroCAD® 10.10-6a s/n 00455 © 2020 HydroCAD Software Solutions LLC

Type III 24-hr 25-year Rainfall=5.80"

Printed 11/5/2021

Page 67

Summary for Subcatchment 1S: Roof

Runoff = 9.28 cfs @ 12.08 hrs, Volume= 32,980 cf, Depth> 5.56"
Routed to Pond 4P : Detention Chambers sC 740

Runoff by SCS TR-20 method, UH=SCS, Weighted-CN, Time Span= 1.00-36.00 hrs, dt= 0.01 hrs
Type III 24-hr 25-year Rainfall=5.80"

Area (sf)	CN	Description
71,161	98	Roofs, HSG A
71,161		100.00% Impervious Area

Tc (min)	Length (feet)	Slope (ft/ft)	Velocity (ft/sec)	Capacity (cfs)	Description
6.0					Direct Entry,

Subcatchment 1S: Roof

Hydrograph

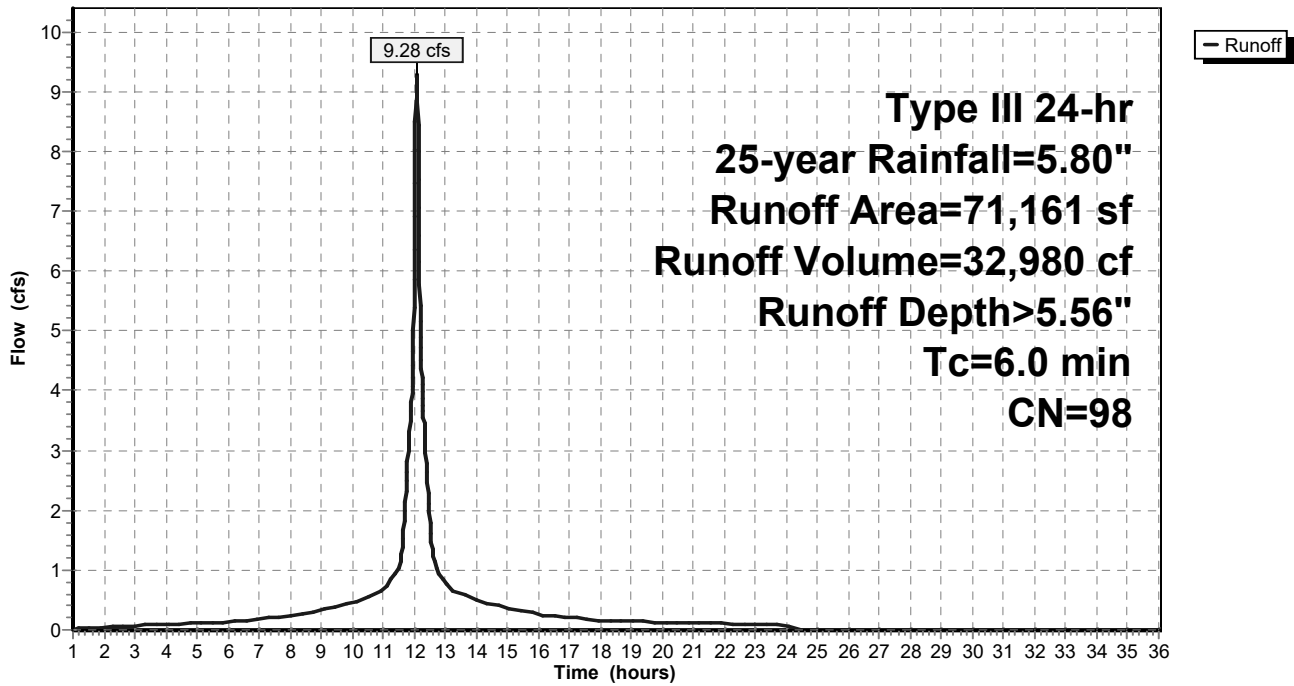

Spofford Post-Development

Prepared by Weston & Sampson

HydroCAD® 10.10-6a s/n 00455 © 2020 HydroCAD Software Solutions LLC

Type III 24-hr 25-year Rainfall=5.80"

Printed 11/5/2021

Page 68

Summary for Subcatchment 2S: Sub 2

Runoff = 0.00 cfs @ 16.78 hrs, Volume= 43 cf, Depth= 0.05"

Routed to Link 1L : Leaching CB

Runoff by SCS TR-20 method, UH=SCS, Weighted-CN, Time Span= 1.00-36.00 hrs, dt= 0.01 hrs
 Type III 24-hr 25-year Rainfall=5.80"

Area (sf)	CN	Description
* 9,774	30	Grass
9,774		100.00% Pervious Area

Tc (min)	Length (feet)	Slope (ft/ft)	Velocity (ft/sec)	Capacity (cfs)	Description
6.0					Direct Entry,

Subcatchment 2S: Sub 2

Hydrograph

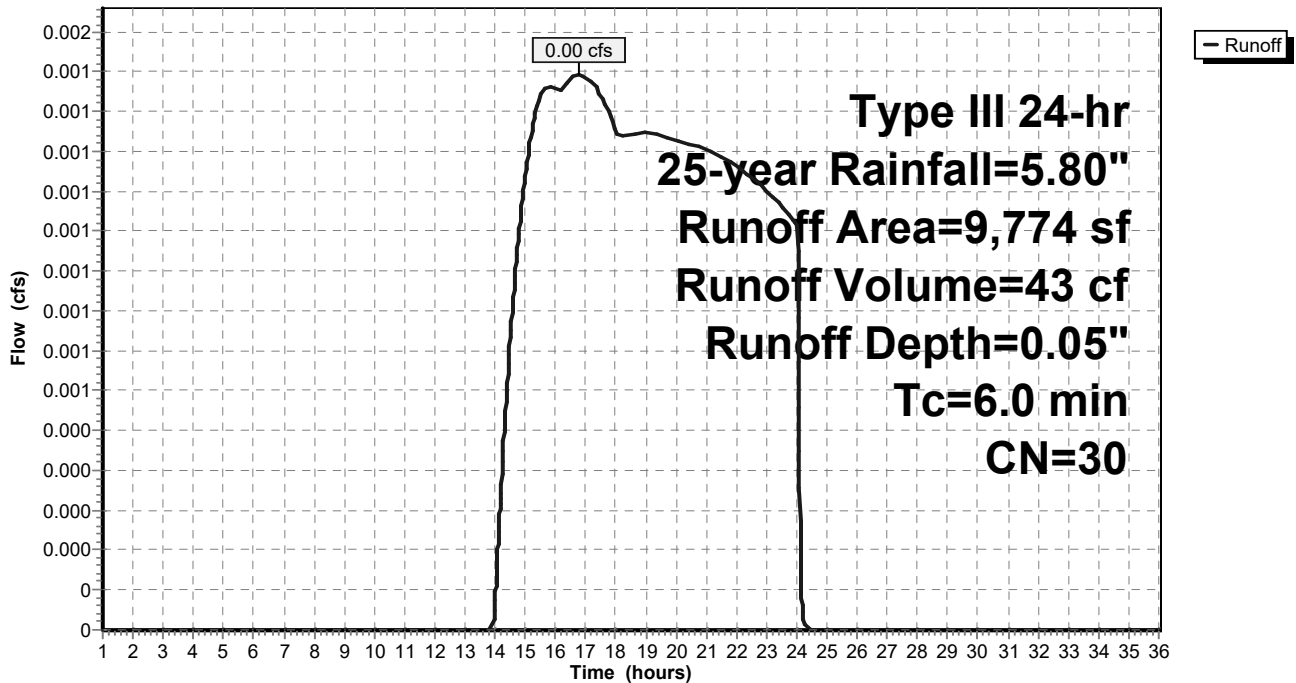

Spofford Post-Development

Prepared by Weston & Sampson

HydroCAD® 10.10-6a s/n 00455 © 2020 HydroCAD Software Solutions LLC

Type III 24-hr 25-year Rainfall=5.80"

Printed 11/5/2021

Page 69

Summary for Subcatchment 3S: Sub 3

Runoff = 2.39 cfs @ 12.09 hrs, Volume= 7,422 cf, Depth= 3.60"
 Routed to Pond 4P : Detention Chambers sC 740

Runoff by SCS TR-20 method, UH=SCS, Weighted-CN, Time Span= 1.00-36.00 hrs, dt= 0.01 hrs
 Type III 24-hr 25-year Rainfall=5.80"

Area (sf)	CN	Description
8,972	98	Paved parking, HSG A
* 9,104	98	Turf (impervious)
* 5,760	30	Grass
894	30	Woods, Good, HSG A
24,730	80	Weighted Average
6,654		26.91% Pervious Area
18,076		73.09% Impervious Area

Tc (min)	Length (feet)	Slope (ft/ft)	Velocity (ft/sec)	Capacity (cfs)	Description
6.0					Direct Entry,

Subcatchment 3S: Sub 3

Hydrograph

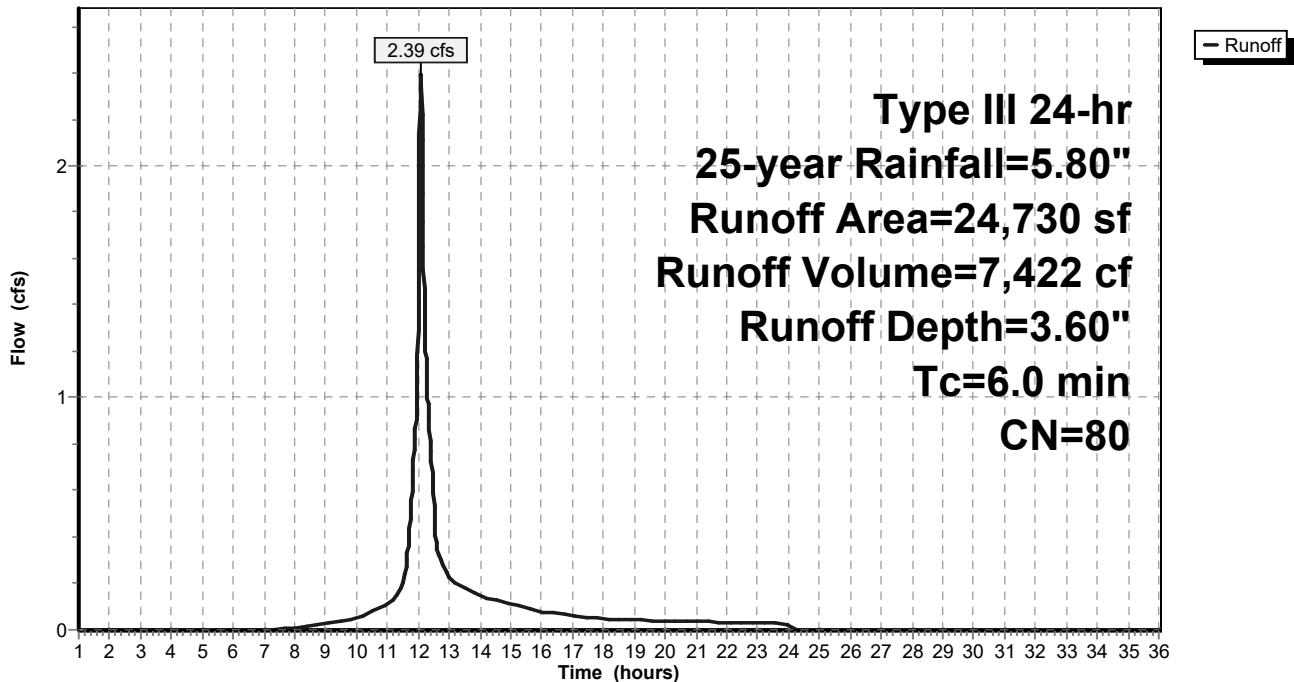

Spofford Post-Development

Prepared by Weston & Sampson

HydroCAD® 10.10-6a s/n 00455 © 2020 HydroCAD Software Solutions LLC

Type III 24-hr 25-year Rainfall=5.80"

Printed 11/5/2021

Page 70

Summary for Subcatchment 4S: Sub 4

Runoff = 1.06 cfs @ 12.09 hrs, Volume= 3,291 cf, Depth= 2.83"
 Routed to Pond 4P : Detention Chambers sC 740

Runoff by SCS TR-20 method, UH=SCS, Weighted-CN, Time Span= 1.00-36.00 hrs, dt= 0.01 hrs
 Type III 24-hr 25-year Rainfall=5.80"

Area (sf)	CN	Description
8,691	98	Paved parking, HSG A
2,060	30	Woods, Good, HSG A
* 3,200	30	Grass
13,951	72	Weighted Average
5,260		37.70% Pervious Area
8,691		62.30% Impervious Area

Tc (min)	Length (feet)	Slope (ft/ft)	Velocity (ft/sec)	Capacity (cfs)	Description
6.0					Direct Entry,

Subcatchment 4S: Sub 4

Hydrograph

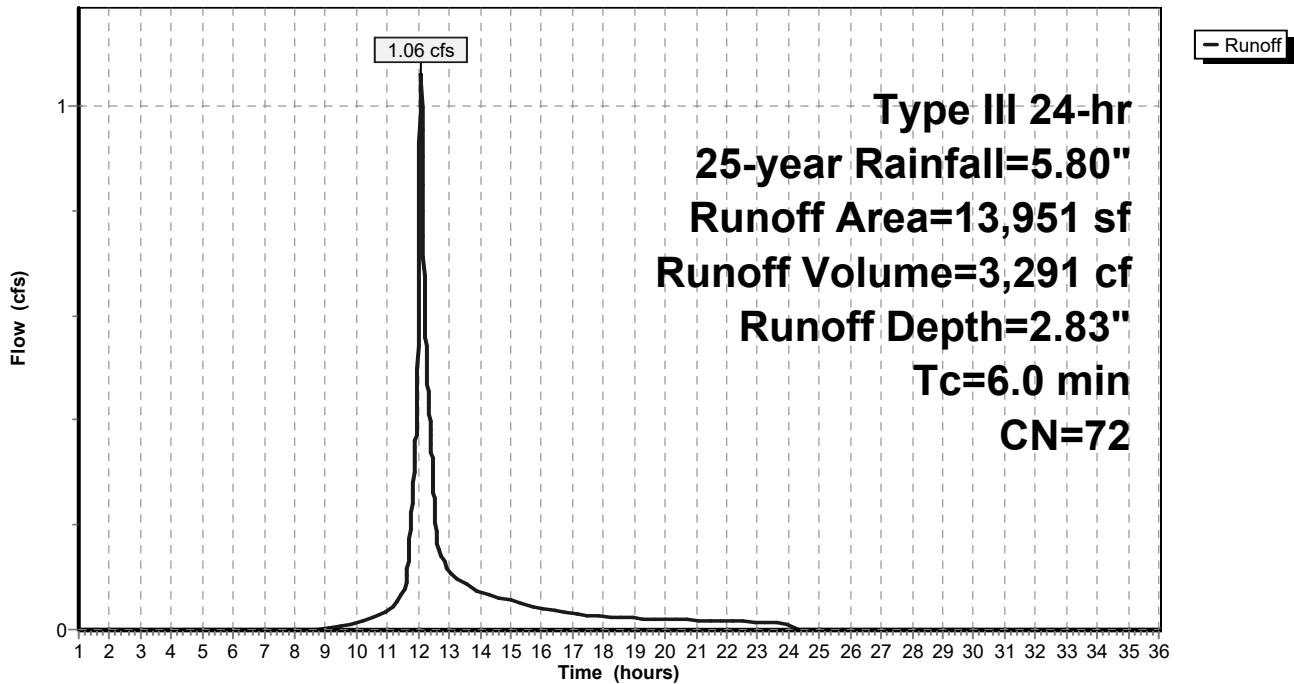

Spofford Post-Development

Prepared by Weston & Sampson

HydroCAD® 10.10-6a s/n 00455 © 2020 HydroCAD Software Solutions LLC

Type III 24-hr 25-year Rainfall=5.80"

Printed 11/5/2021

Page 71

Summary for Subcatchment 5S: Sub 5

Runoff = 1.08 cfs @ 12.09 hrs, Volume= 3,389 cf, Depth= 4.01"
 Routed to Pond 4P : Detention Chambers sC 740

Runoff by SCS TR-20 method, UH=SCS, Weighted-CN, Time Span= 1.00-36.00 hrs, dt= 0.01 hrs
 Type III 24-hr 25-year Rainfall=5.80"

Area (sf)	CN	Description
8,108	98	Paved parking, HSG A
* 2,034	30	Grass
10,142	84	Weighted Average
2,034		20.06% Pervious Area
8,108		79.94% Impervious Area

Tc (min)	Length (feet)	Slope (ft/ft)	Velocity (ft/sec)	Capacity (cfs)	Description
6.0					Direct Entry,

Subcatchment 5S: Sub 5

Hydrograph

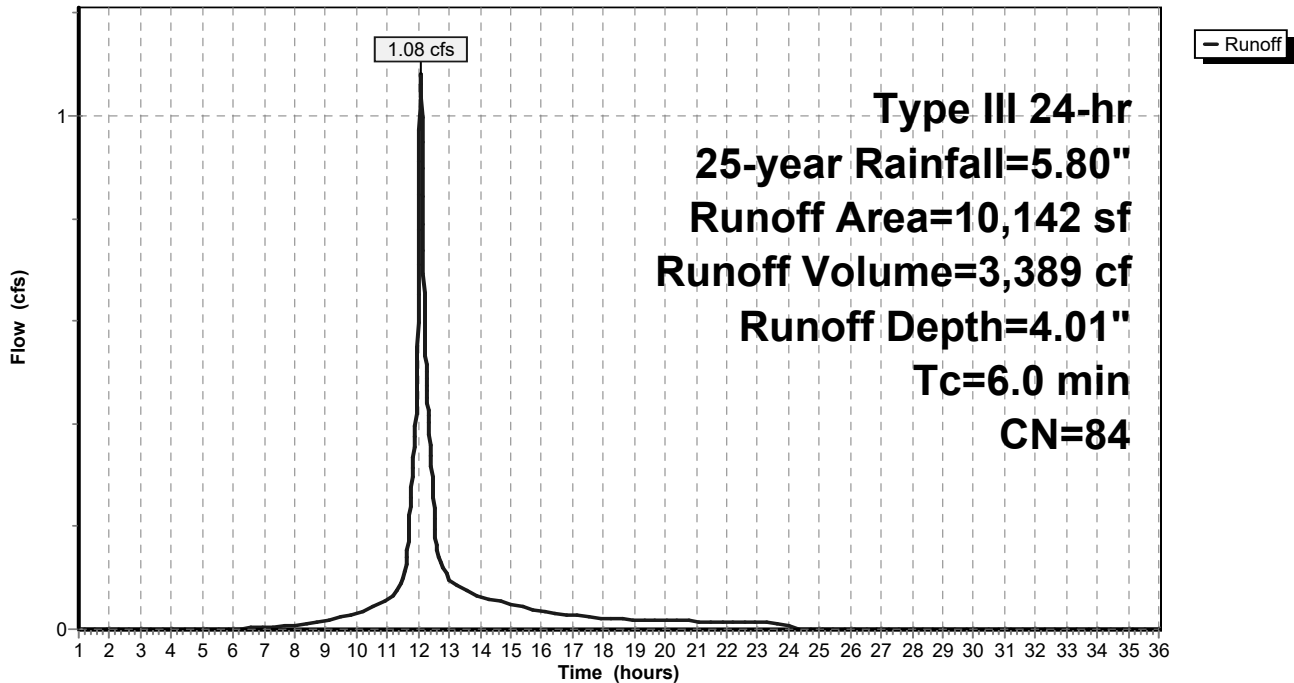

Spofford Post-Development

Prepared by Weston & Sampson

HydroCAD® 10.10-6a s/n 00455 © 2020 HydroCAD Software Solutions LLC

Type III 24-hr 25-year Rainfall=5.80"

Printed 11/5/2021

Page 72

Summary for Subcatchment 6S: Sub 6

Runoff = 0.06 cfs @ 12.37 hrs, Volume= 609 cf, Depth= 0.39"

Routed to Link 3L : Spofford Pond Wetlands

Runoff by SCS TR-20 method, UH=SCS, Weighted-CN, Time Span= 1.00-36.00 hrs, dt= 0.01 hrs
 Type III 24-hr 25-year Rainfall=5.80"

	Area (sf)	CN	Description
*	8,202	30	Grass
	7,952	30	Woods, Good, HSG A
	2,600	98	Paved parking, HSG A
	18,754	39	Weighted Average
	16,154		86.14% Pervious Area
	2,600		13.86% Impervious Area

Tc (min)	Length (feet)	Slope (ft/ft)	Velocity (ft/sec)	Capacity (cfs)	Description
6.0					Direct Entry,

Subcatchment 6S: Sub 6

Hydrograph

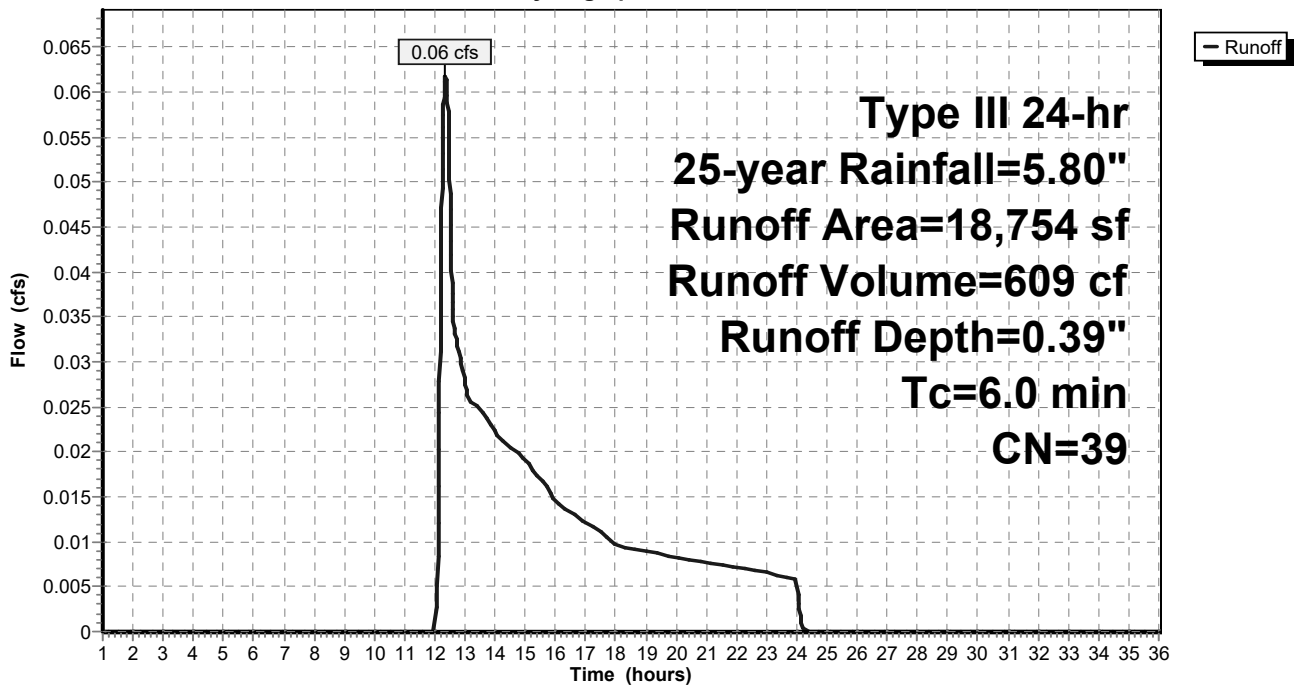

Spofford Post-Development

Prepared by Weston & Sampson

HydroCAD® 10.10-6a s/n 00455 © 2020 HydroCAD Software Solutions LLC

Type III 24-hr 25-year Rainfall=5.80"

Printed 11/5/2021

Page 73

Summary for Subcatchment 7S: Sub 7

Runoff = 0.61 cfs @ 12.08 hrs, Volume= 2,166 cf, Depth> 5.56"
Routed to Pond 4P : Detention Chambers sC 740

Runoff by SCS TR-20 method, UH=SCS, Weighted-CN, Time Span= 1.00-36.00 hrs, dt= 0.01 hrs
Type III 24-hr 25-year Rainfall=5.80"

Area (sf)	CN	Description
4,674	98	Paved parking, HSG A
4,674		100.00% Impervious Area

Tc (min)	Length (feet)	Slope (ft/ft)	Velocity (ft/sec)	Capacity (cfs)	Description
6.0					Direct Entry,

Subcatchment 7S: Sub 7

Hydrograph

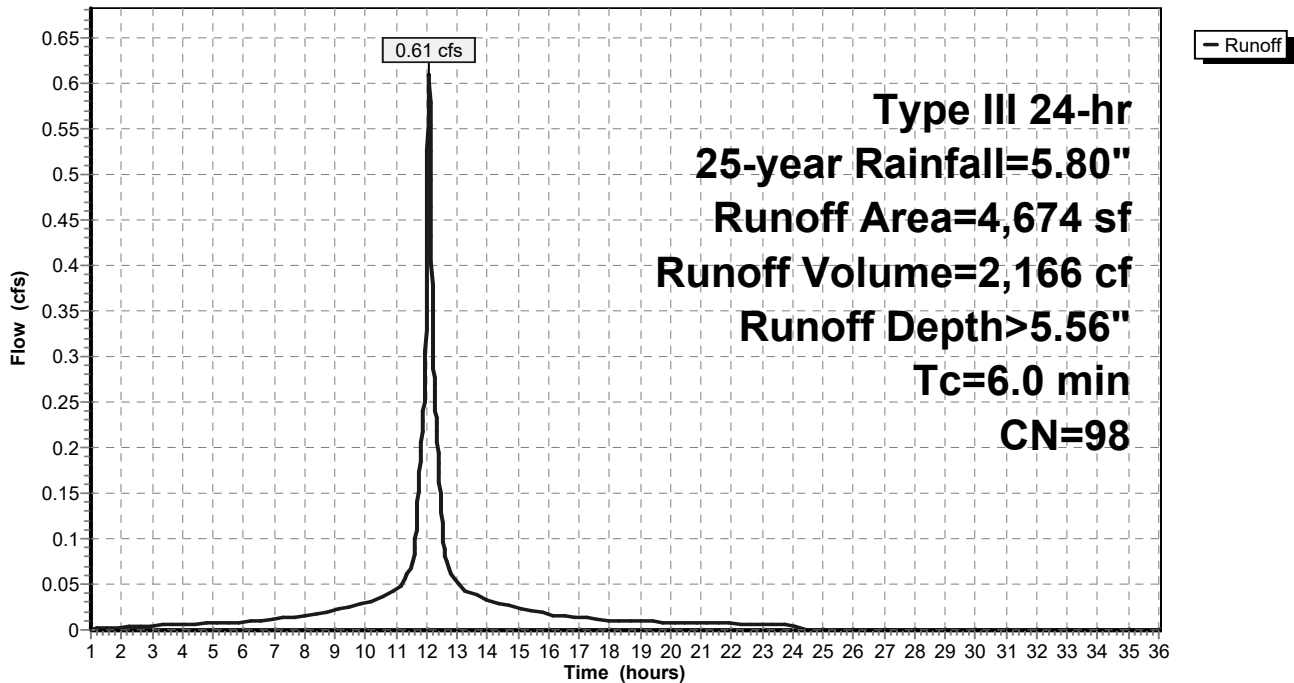

Spofford Post-Development

Prepared by Weston & Sampson

HydroCAD® 10.10-6a s/n 00455 © 2020 HydroCAD Software Solutions LLC

Type III 24-hr 25-year Rainfall=5.80"

Printed 11/5/2021

Page 74

Summary for Subcatchment 8S: Sub 8

Runoff = 0.00 cfs @ 16.78 hrs, Volume= 104 cf, Depth= 0.05"

Routed to Link 3L : Spofford Pond Wetlands

Runoff by SCS TR-20 method, UH=SCS, Weighted-CN, Time Span= 1.00-36.00 hrs, dt= 0.01 hrs
Type III 24-hr 25-year Rainfall=5.80"

	Area (sf)	CN	Description
*	23,822	30	Grass
	23,822		100.00% Pervious Area

Tc (min)	Length (feet)	Slope (ft/ft)	Velocity (ft/sec)	Capacity (cfs)	Description
6.0					Direct Entry,

Subcatchment 8S: Sub 8

Hydrograph

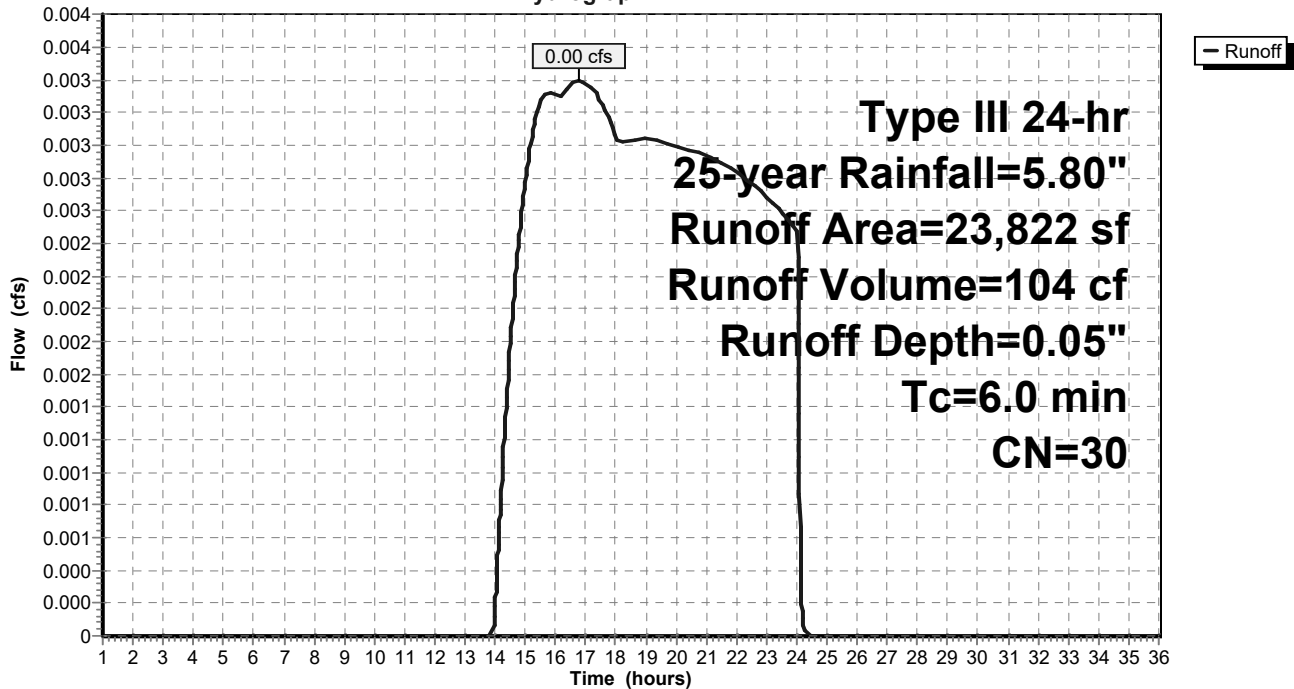

Spofford Post-Development

Prepared by Weston & Sampson

HydroCAD® 10.10-6a s/n 00455 © 2020 HydroCAD Software Solutions LLC

Type III 24-hr 25-year Rainfall=5.80"

Printed 11/5/2021

Page 75

Summary for Subcatchment 9S: Sub 9

Runoff = 1.20 cfs @ 12.08 hrs, Volume= 4,074 cf, Depth= 5.21"
 Routed to Pond 4P : Detention Chambers sC 740

Runoff by SCS TR-20 method, UH=SCS, Weighted-CN, Time Span= 1.00-36.00 hrs, dt= 0.01 hrs
 Type III 24-hr 25-year Rainfall=5.80"

Area (sf)	CN	Description
8,974	98	Paved parking, HSG A
* 405	30	Grass
9,379	95	Weighted Average
405		4.32% Pervious Area
8,974		95.68% Impervious Area

Tc (min)	Length (feet)	Slope (ft/ft)	Velocity (ft/sec)	Capacity (cfs)	Description
6.0					Direct Entry,

Subcatchment 9S: Sub 9

Hydrograph

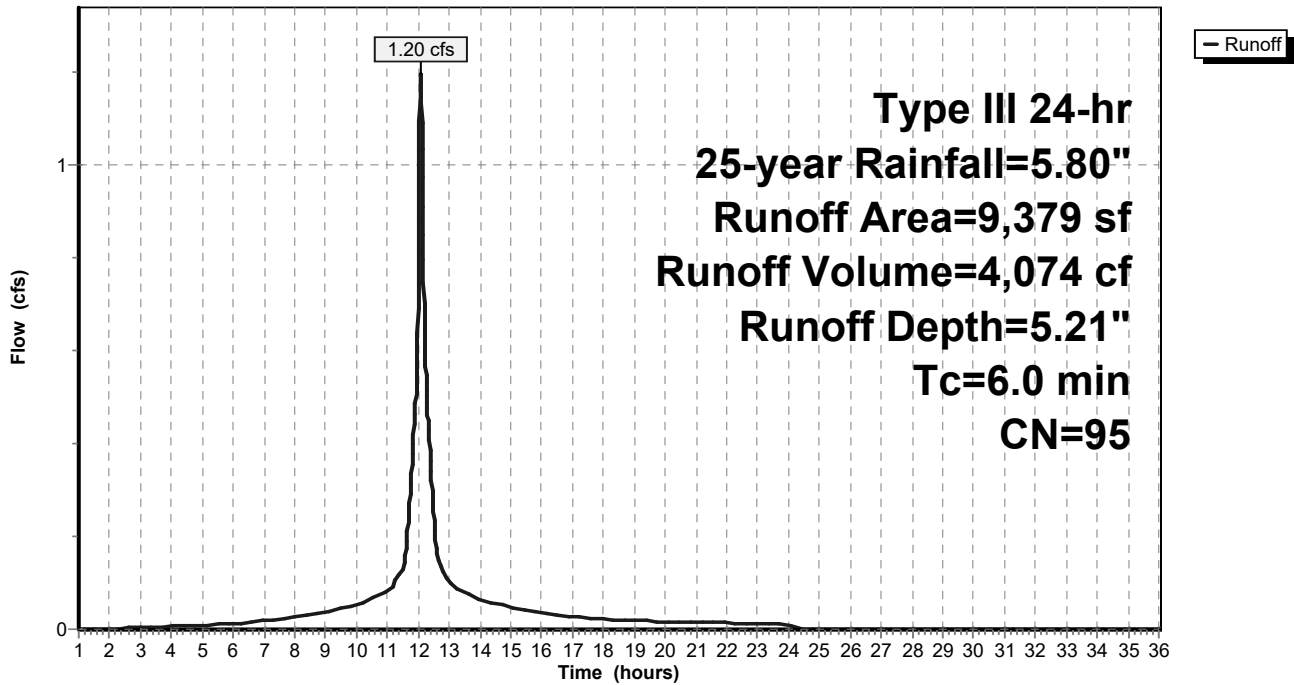

Spofford Post-Development

Prepared by Weston & Sampson

HydroCAD® 10.10-6a s/n 00455 © 2020 HydroCAD Software Solutions LLC

Type III 24-hr 25-year Rainfall=5.80"

Printed 11/5/2021

Page 76

Summary for Subcatchment 10S: Sub 10

Runoff = 1.65 cfs @ 12.09 hrs, Volume= 5,104 cf, Depth= 3.31"
 Routed to Pond 4P : Detention Chambers sC 740

Runoff by SCS TR-20 method, UH=SCS, Weighted-CN, Time Span= 1.00-36.00 hrs, dt= 0.01 hrs
 Type III 24-hr 25-year Rainfall=5.80"

Area (sf)	CN	Description
12,796	98	Paved parking, HSG A
424	30	Woods, Good, HSG A
* 5,312	30	Grass
18,532	77	Weighted Average
5,736		30.95% Pervious Area
12,796		69.05% Impervious Area

Tc (min)	Length (feet)	Slope (ft/ft)	Velocity (ft/sec)	Capacity (cfs)	Description
6.0					Direct Entry,

Subcatchment 10S: Sub 10

Hydrograph

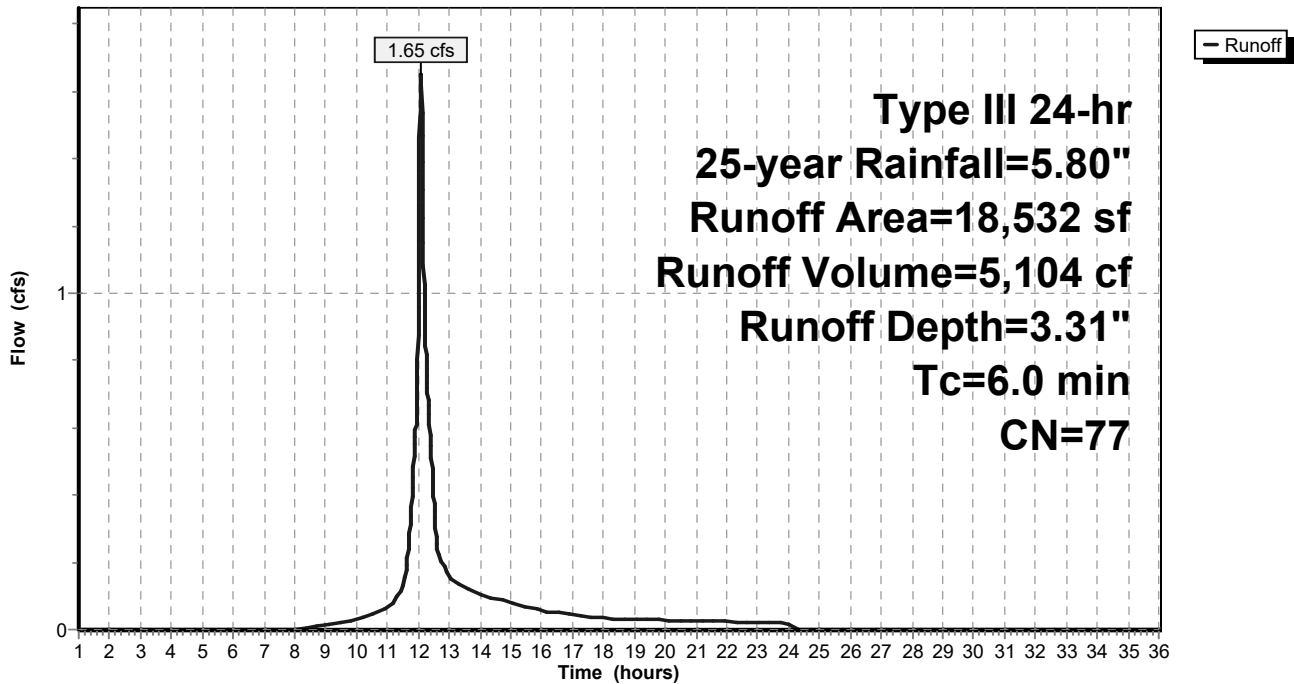

Spofford Post-Development

Prepared by Weston & Sampson

HydroCAD® 10.10-6a s/n 00455 © 2020 HydroCAD Software Solutions LLC

Type III 24-hr 25-year Rainfall=5.80"

Printed 11/5/2021

Page 77

Summary for Subcatchment 11S: Sub 11

Runoff = 0.88 cfs @ 12.08 hrs, Volume= 3,089 cf, Depth= 5.44"
 Routed to Pond 4P : Detention Chambers sC 740

Runoff by SCS TR-20 method, UH=SCS, Weighted-CN, Time Span= 1.00-36.00 hrs, dt= 0.01 hrs
 Type III 24-hr 25-year Rainfall=5.80"

Area (sf)	CN	Description
6,701	98	Paved parking, HSG A
* 107	30	Grass
6,808	97	Weighted Average
107		1.57% Pervious Area
6,701		98.43% Impervious Area

Tc (min)	Length (feet)	Slope (ft/ft)	Velocity (ft/sec)	Capacity (cfs)	Description
6.0					Direct Entry,

Subcatchment 11S: Sub 11

Hydrograph

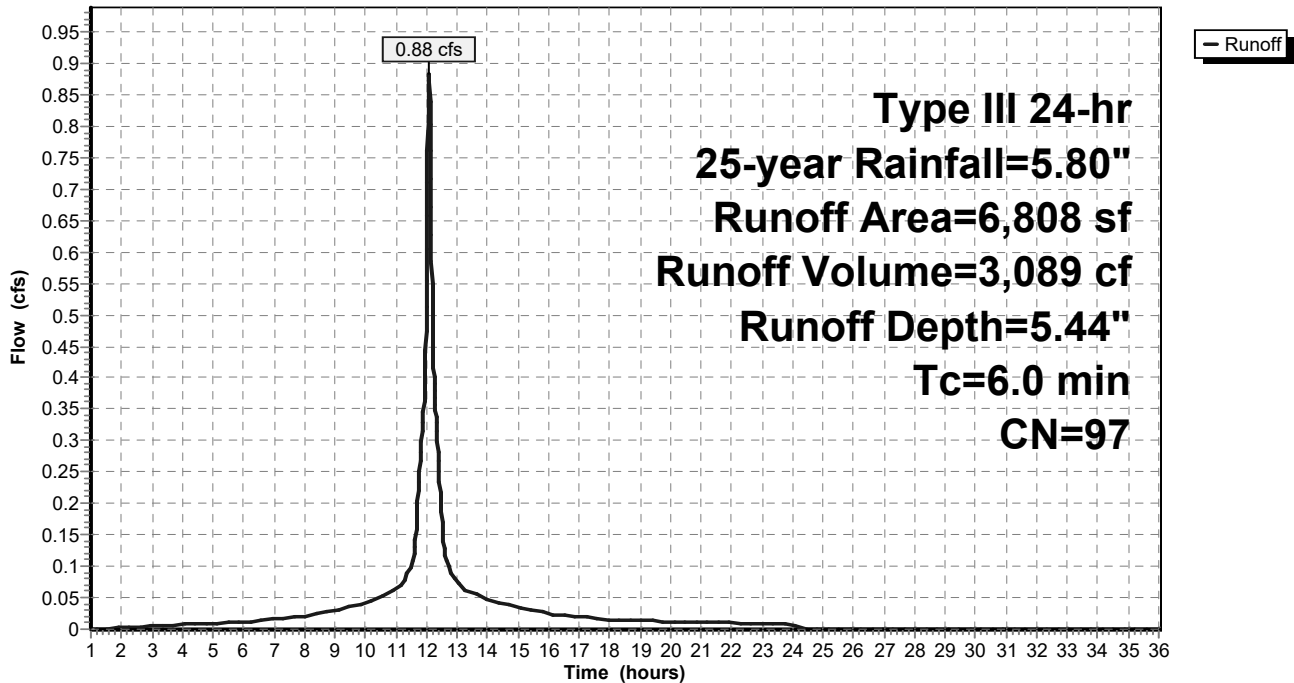

Spofford Post-Development

Prepared by Weston & Sampson

HydroCAD® 10.10-6a s/n 00455 © 2020 HydroCAD Software Solutions LLC

Type III 24-hr 25-year Rainfall=5.80"

Printed 11/5/2021

Page 78

Summary for Subcatchment 12S: Sub 12

Runoff = 0.00 cfs @ 16.78 hrs, Volume= 24 cf, Depth= 0.05"
 Routed to Link 2L : Isolated Wetlands

Runoff by SCS TR-20 method, UH=SCS, Weighted-CN, Time Span= 1.00-36.00 hrs, dt= 0.01 hrs
 Type III 24-hr 25-year Rainfall=5.80"

Area (sf)	CN	Description
* 5,470	30	Grass
5,470		100.00% Pervious Area

Tc (min)	Length (feet)	Slope (ft/ft)	Velocity (ft/sec)	Capacity (cfs)	Description
6.0					Direct Entry,

Subcatchment 12S: Sub 12

Hydrograph

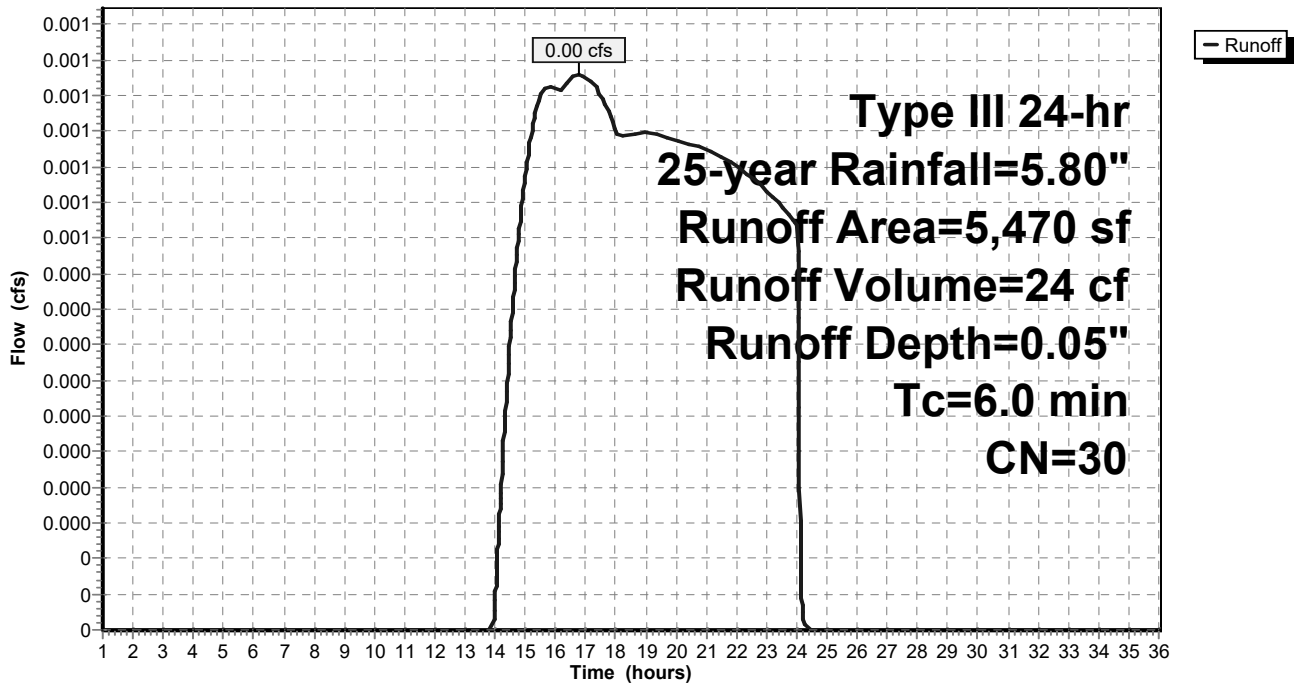

Spofford Post-Development

Prepared by Weston & Sampson

HydroCAD® 10.10-6a s/n 00455 © 2020 HydroCAD Software Solutions LLC

Type III 24-hr 25-year Rainfall=5.80"

Printed 11/5/2021

Page 79

Summary for Subcatchment 13S: Sub 13

Runoff = 0.40 cfs @ 12.08 hrs, Volume= 1,286 cf, Depth= 4.65"
 Routed to Pond 4P : Detention Chambers sC 740

Runoff by SCS TR-20 method, UH=SCS, Weighted-CN, Time Span= 1.00-36.00 hrs, dt= 0.01 hrs
 Type III 24-hr 25-year Rainfall=5.80"

Area (sf)	CN	Description
2,910	98	Paved parking, HSG A
* 408	30	Grass
3,318	90	Weighted Average
408		12.30% Pervious Area
2,910		87.70% Impervious Area

Tc (min)	Length (feet)	Slope (ft/ft)	Velocity (ft/sec)	Capacity (cfs)	Description
6.0					Direct Entry,

Subcatchment 13S: Sub 13

Hydrograph

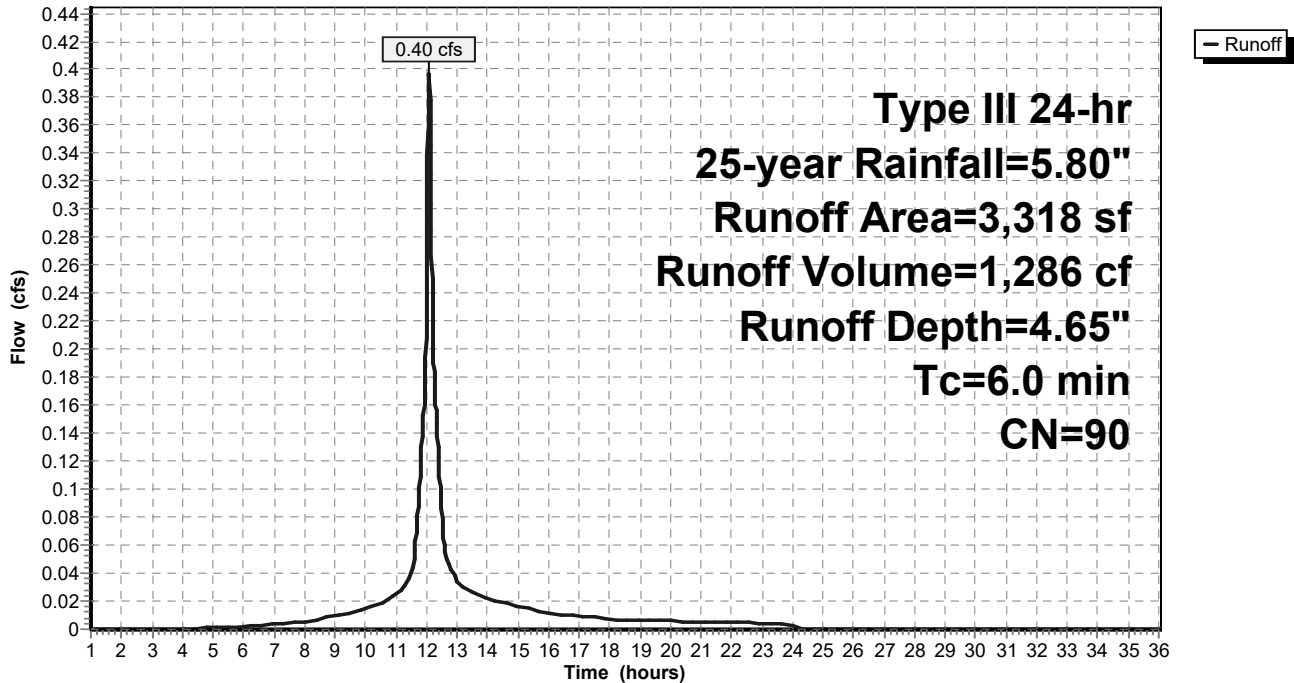

Spofford Post-Development

Prepared by Weston & Sampson

HydroCAD® 10.10-6a s/n 00455 © 2020 HydroCAD Software Solutions LLC

Type III 24-hr 25-year Rainfall=5.80"

Printed 11/5/2021

Page 80

Summary for Subcatchment 14S: Sub 14

Runoff = 0.50 cfs @ 12.08 hrs, Volume= 1,693 cf, Depth= 5.21"
Routed to Pond 4P : Detention Chambers sC 740

Runoff by SCS TR-20 method, UH=SCS, Weighted-CN, Time Span= 1.00-36.00 hrs, dt= 0.01 hrs
Type III 24-hr 25-year Rainfall=5.80"

Area (sf)	CN	Description
3,743	98	Paved parking, HSG A
* 155	30	Grass
3,898	95	Weighted Average
155		3.98% Pervious Area
3,743		96.02% Impervious Area

Tc (min)	Length (feet)	Slope (ft/ft)	Velocity (ft/sec)	Capacity (cfs)	Description
6.0					Direct Entry,

Subcatchment 14S: Sub 14

Hydrograph

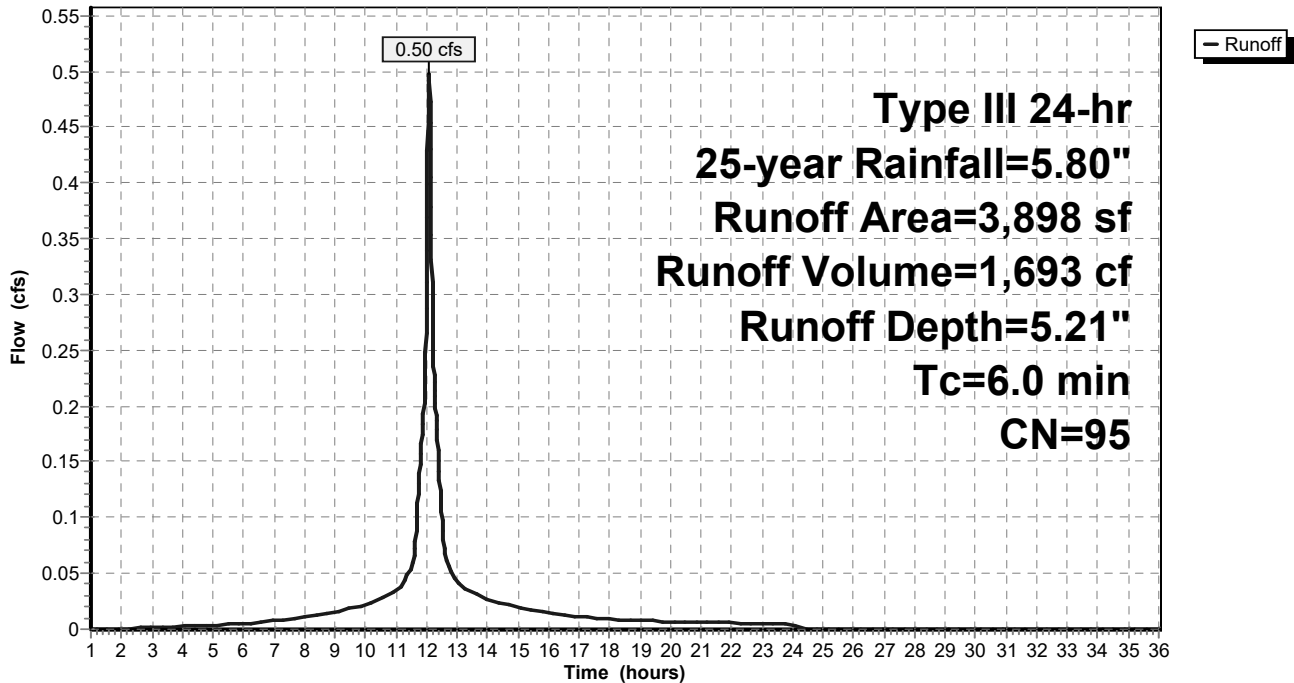

Spofford Post-Development

Prepared by Weston & Sampson

HydroCAD® 10.10-6a s/n 00455 © 2020 HydroCAD Software Solutions LLC

Type III 24-hr 25-year Rainfall=5.80"

Printed 11/5/2021

Page 81

Summary for Subcatchment 15S: Sub 15

Runoff = 5.98 cfs @ 12.08 hrs, Volume= 20,597 cf, Depth= 5.33"

Routed to Pond 3P : Sediment Forebay

Runoff by SCS TR-20 method, UH=SCS, Weighted-CN, Time Span= 1.00-36.00 hrs, dt= 0.01 hrs
Type III 24-hr 25-year Rainfall=5.80"

	Area (sf)	CN	Description
*	1,568	30	Grass
	44,820	98	Paved parking, HSG A
	46,388	96	Weighted Average
	1,568		3.38% Pervious Area
	44,820		96.62% Impervious Area

Tc (min)	Length (feet)	Slope (ft/ft)	Velocity (ft/sec)	Capacity (cfs)	Description
6.0					Direct Entry,

Subcatchment 15S: Sub 15

Hydrograph

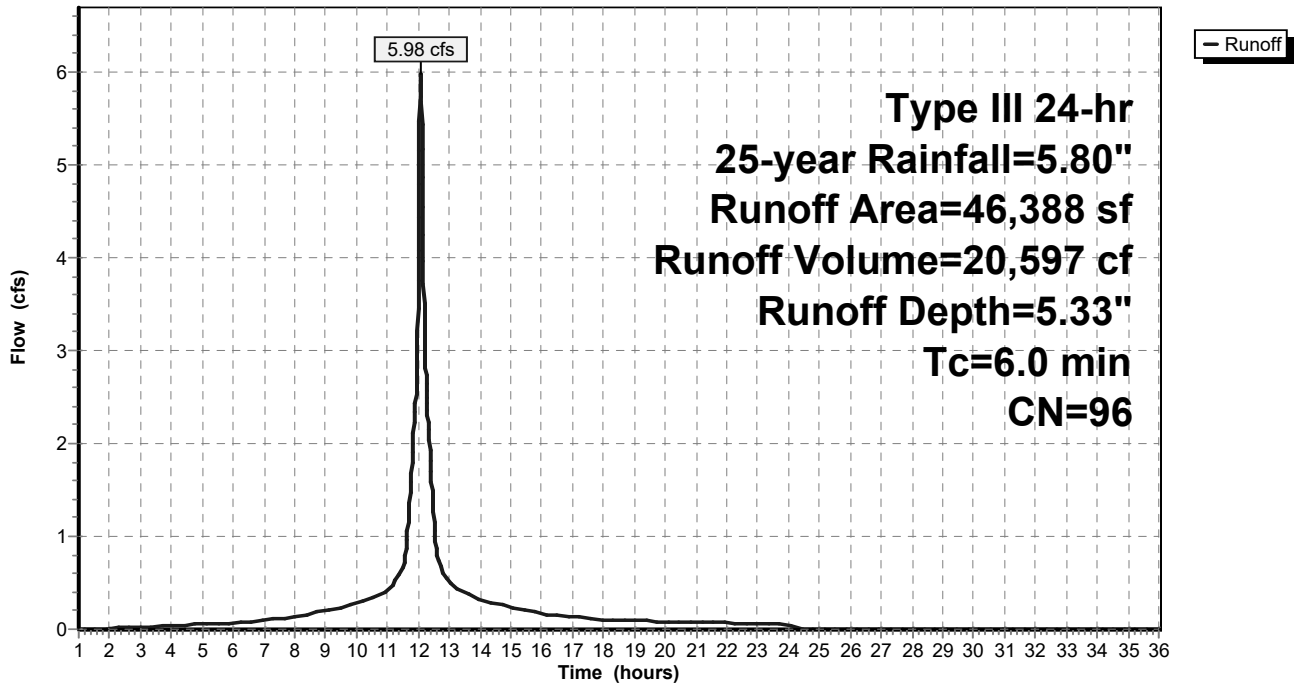

Spofford Post-Development

Prepared by Weston & Sampson

HydroCAD® 10.10-6a s/n 00455 © 2020 HydroCAD Software Solutions LLC

Type III 24-hr 25-year Rainfall=5.80"

Printed 11/5/2021

Page 82

Summary for Subcatchment 16S: Sub 16

Runoff = 1.40 cfs @ 12.08 hrs, Volume= 4,662 cf, Depth= 4.99"
 Routed to Pond 4P : Detention Chambers sC 740

Runoff by SCS TR-20 method, UH=SCS, Weighted-CN, Time Span= 1.00-36.00 hrs, dt= 0.01 hrs
 Type III 24-hr 25-year Rainfall=5.80"

Area (sf)	CN	Description
10,400	98	Paved parking, HSG A
* 822	30	Grass
11,222	93	Weighted Average
822		7.32% Pervious Area
10,400		92.68% Impervious Area

Tc (min)	Length (feet)	Slope (ft/ft)	Velocity (ft/sec)	Capacity (cfs)	Description
6.0					Direct Entry,

Subcatchment 16S: Sub 16

Hydrograph

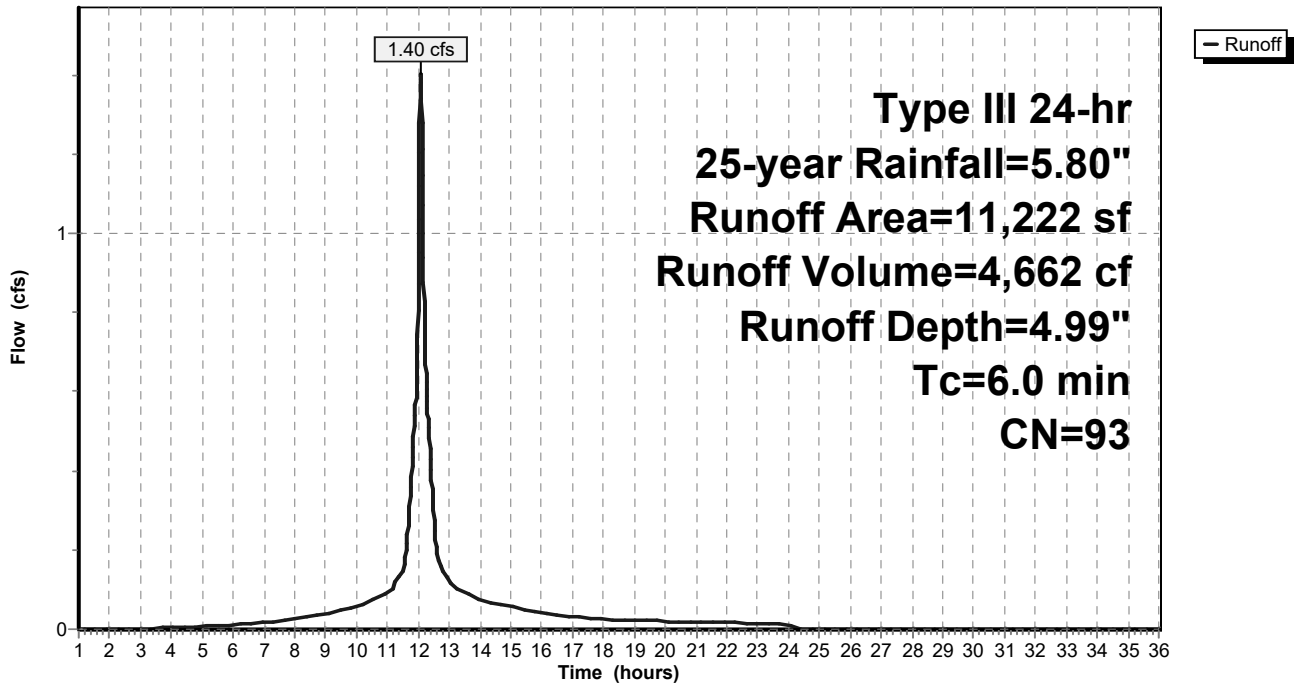

Spofford Post-Development

Prepared by Weston & Sampson

HydroCAD® 10.10-6a s/n 00455 © 2020 HydroCAD Software Solutions LLC

Type III 24-hr 25-year Rainfall=5.80"

Printed 11/5/2021

Page 83

Summary for Subcatchment 17S: Sub 17

Runoff = 1.41 cfs @ 12.08 hrs, Volume= 4,923 cf, Depth= 5.44"
 Routed to Pond 4P : Detention Chambers sC 740

Runoff by SCS TR-20 method, UH=SCS, Weighted-CN, Time Span= 1.00-36.00 hrs, dt= 0.01 hrs
 Type III 24-hr 25-year Rainfall=5.80"

Area (sf)	CN	Description
* 155	30	Grass
10,696	98	Paved parking, HSG A
10,851	97	Weighted Average
155		1.43% Pervious Area
10,696		98.57% Impervious Area

Tc (min)	Length (feet)	Slope (ft/ft)	Velocity (ft/sec)	Capacity (cfs)	Description
6.0					Direct Entry,

Subcatchment 17S: Sub 17

Hydrograph

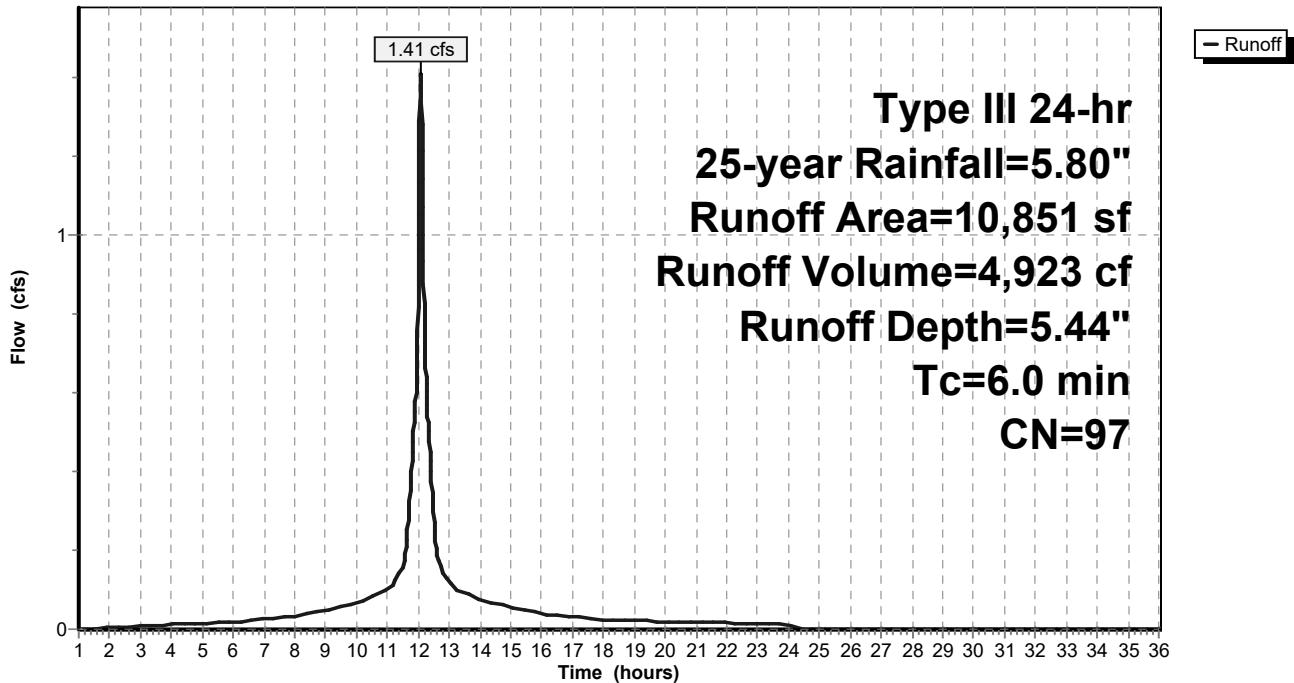

Spofford Post-Development

Prepared by Weston & Sampson

HydroCAD® 10.10-6a s/n 00455 © 2020 HydroCAD Software Solutions LLC

Type III 24-hr 25-year Rainfall=5.80"

Printed 11/5/2021

Page 84

Summary for Subcatchment 18S: Sub 18

Runoff = 0.00 cfs @ 14.74 hrs, Volume= 122 cf, Depth= 0.14"
 Routed to Link 4L : Vernal Pool Wetlands

Runoff by SCS TR-20 method, UH=SCS, Weighted-CN, Time Span= 1.00-36.00 hrs, dt= 0.01 hrs
 Type III 24-hr 25-year Rainfall=5.80"

	Area (sf)	CN	Description
*	5,866	30	Grass
	397	98	Paved parking, HSG A
	4,427	30	Woods, Good, HSG A
	10,690	33	Weighted Average
	10,293		96.29% Pervious Area
	397		3.71% Impervious Area

Tc (min)	Length (feet)	Slope (ft/ft)	Velocity (ft/sec)	Capacity (cfs)	Description
6.0					Direct Entry,

Subcatchment 18S: Sub 18

Hydrograph

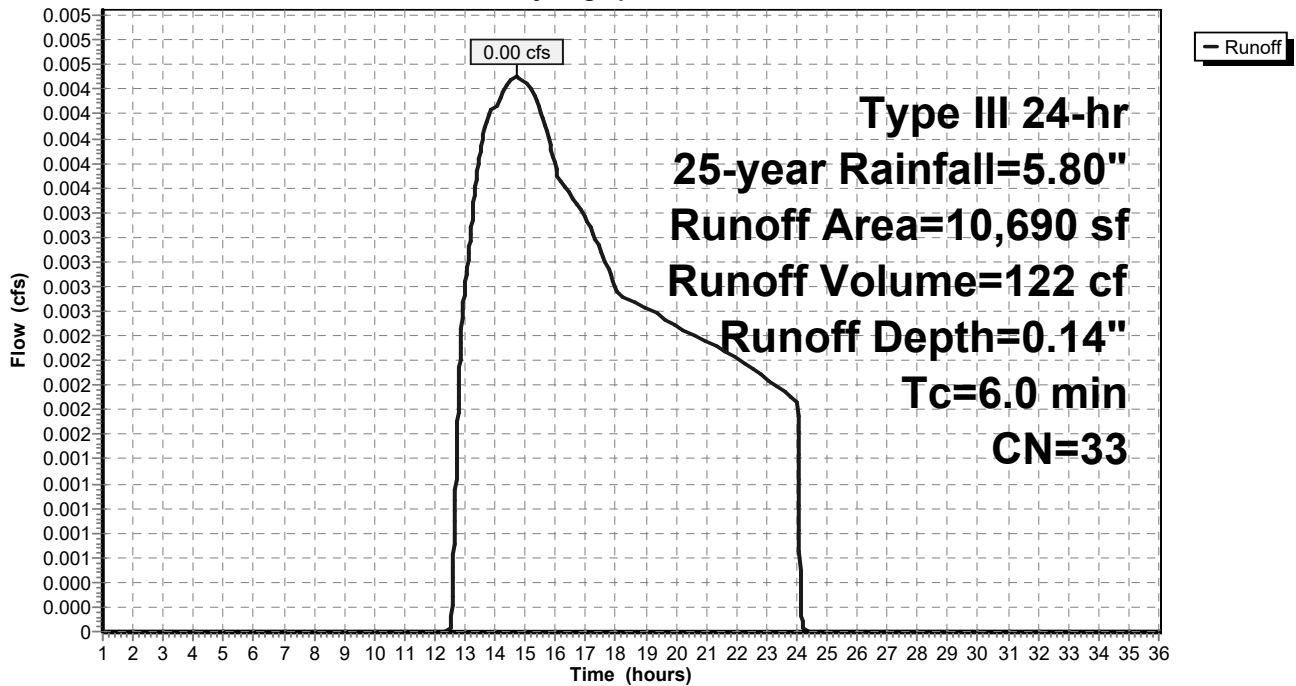

Spofford Post-Development

Prepared by Weston & Sampson

HydroCAD® 10.10-6a s/n 00455 © 2020 HydroCAD Software Solutions LLC

Type III 24-hr 25-year Rainfall=5.80"

Printed 11/5/2021

Page 85

Summary for Subcatchment 19S: Sub 19

Runoff = 0.00 cfs @ 16.78 hrs, Volume= 17 cf, Depth= 0.05"

Routed to Link 2L : Isolated Wetlands

Runoff by SCS TR-20 method, UH=SCS, Weighted-CN, Time Span= 1.00-36.00 hrs, dt= 0.01 hrs
 Type III 24-hr 25-year Rainfall=5.80"

Area (sf)	CN	Description
* 3,953	30	Grass
3,953		100.00% Pervious Area

Tc (min)	Length (feet)	Slope (ft/ft)	Velocity (ft/sec)	Capacity (cfs)	Description
6.0					Direct Entry,

Subcatchment 19S: Sub 19

Hydrograph

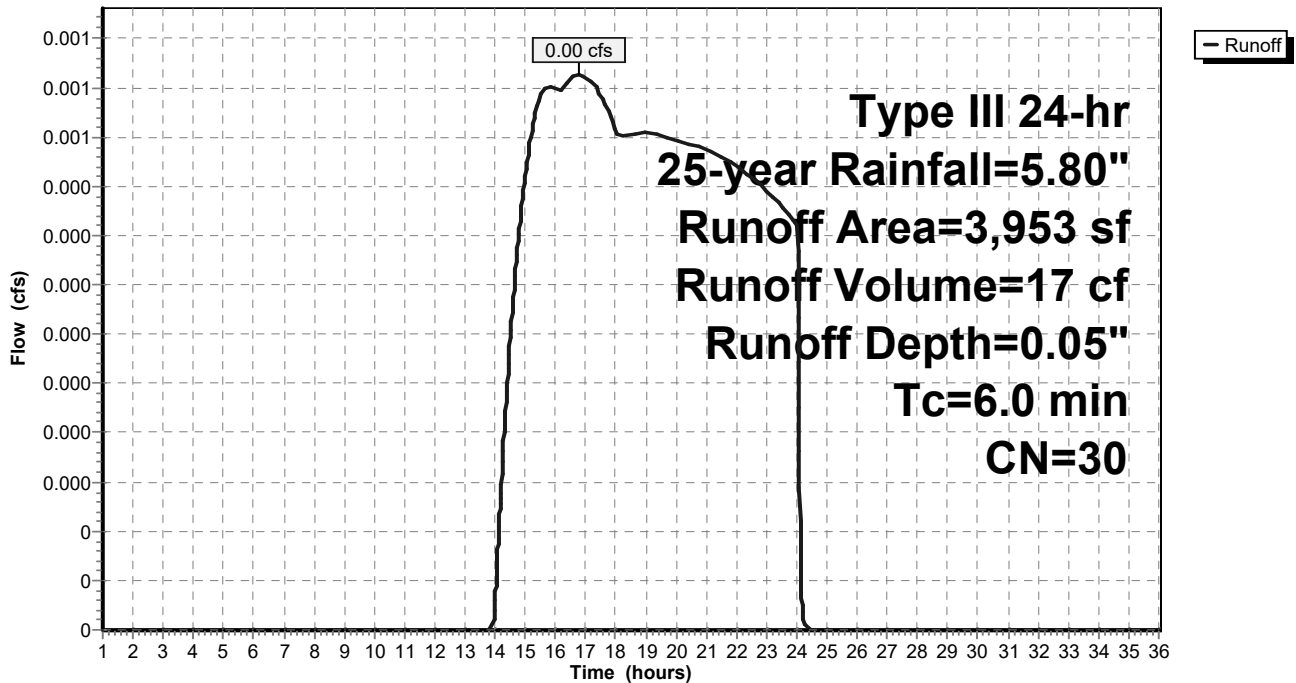

Spofford Post-Development

Prepared by Weston & Sampson

HydroCAD® 10.10-6a s/n 00455 © 2020 HydroCAD Software Solutions LLC

Type III 24-hr 25-year Rainfall=5.80"

Printed 11/5/2021

Page 86

Summary for Pond 3P: Sediment Forebay

Inflow Area = 46,388 sf, 96.62% Impervious, Inflow Depth = 5.33" for 25-year event
 Inflow = 5.98 cfs @ 12.08 hrs, Volume= 20,597 cf
 Outflow = 5.85 cfs @ 12.10 hrs, Volume= 20,223 cf, Atten= 2%, Lag= 1.0 min
 Primary = 5.85 cfs @ 12.10 hrs, Volume= 20,223 cf
 Routed to Pond 4P : Detention Chambers sC 740
 Secondary = 0.00 cfs @ 1.00 hrs, Volume= 0 cf
 Routed to Pond 4P : Detention Chambers sC 740

Routing by Dyn-Stor-Ind method, Time Span= 1.00-36.00 hrs, dt= 0.01 hrs
 Peak Elev= 133.89' @ 12.10 hrs Surf.Area= 1,229 sf Storage= 844 cf

Plug-Flow detention time= 24.1 min calculated for 20,223 cf (98% of inflow)
 Center-of-Mass det. time= 12.4 min (771.3 - 759.0)

Volume	Invert	Avail.Storage	Storage Description
#1	133.00'	979 cf	Custom Stage Data (Irregular) Listed below (Recalc)

Elevation (feet)	Surf.Area (sq-ft)	Perim. (feet)	Inc.Store (cubic-feet)	Cum.Store (cubic-feet)	Wet.Area (sq-ft)
133.00	687	186.0	0	0	687
134.00	1,304	215.0	979	979	1,634

Device	Routing	Invert	Outlet Devices
#1	Primary	128.65'	24.0" Round Culvert L= 29.0' CPP, projecting, no headwall, Ke= 0.900 Inlet / Outlet Invert= 128.65' / 128.50' S= 0.0052 '/' Cc= 0.900 n= 0.013 Corrugated PE, smooth interior, Flow Area= 3.14 sf
#2	Device 1	133.46'	24.0" Horiz. Orifice/Grate C= 0.600 Limited to weir flow at low heads
#3	Secondary	134.00'	215.0' long x 2.0' breadth Broad-Crested Rectangular Weir Head (feet) 0.20 0.40 0.60 0.80 1.00 1.20 1.40 1.60 1.80 2.00 2.50 3.00 3.50 Coef. (English) 2.54 2.61 2.61 2.60 2.66 2.70 2.77 2.89 2.88 2.85 3.07 3.20 3.32

Primary OutFlow Max=5.85 cfs @ 12.10 hrs HW=133.89' TW=129.63' (Dynamic Tailwater)

- ↑1=Culvert (Passes 5.85 cfs of 24.60 cfs potential flow)
- ↑2=Orifice/Grate (Weir Controls 5.85 cfs @ 2.15 fps)

Secondary OutFlow Max=0.00 cfs @ 1.00 hrs HW=133.00' TW=127.76' (Dynamic Tailwater)

- ↑3=Broad-Crested Rectangular Weir (Controls 0.00 cfs)

Pond 3P: Sediment Forebay

Hydrograph

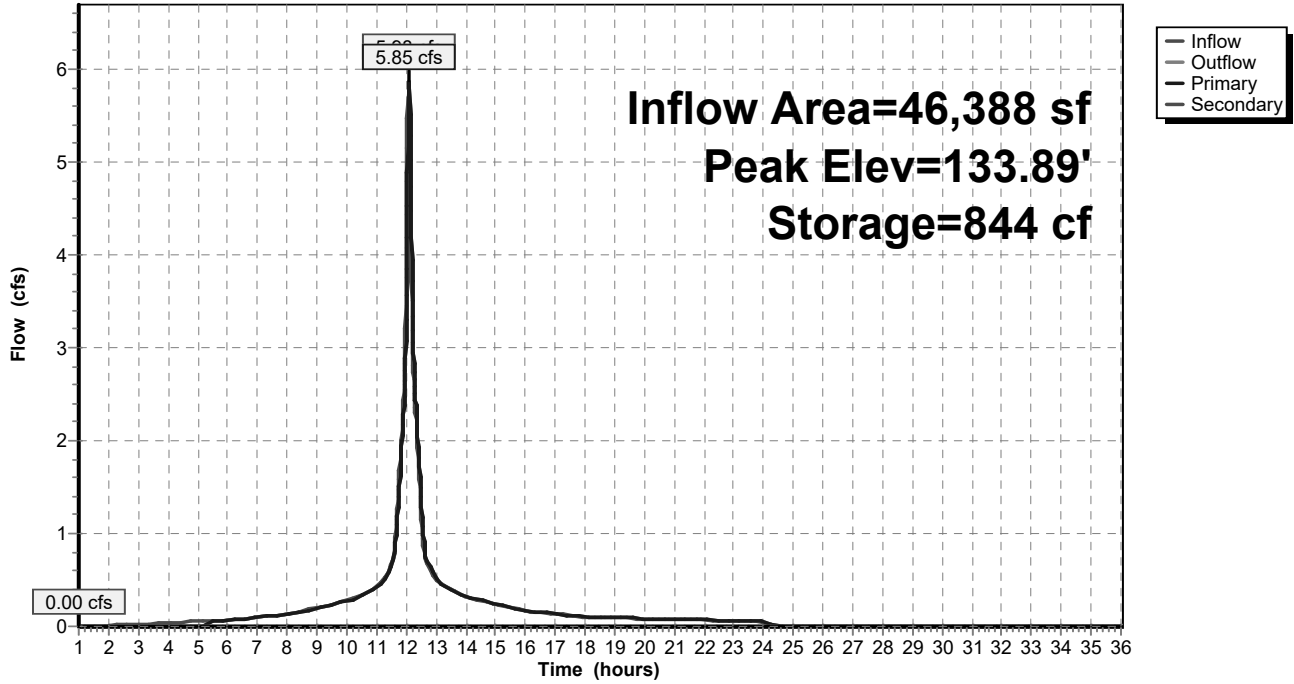

Spofford Post-Development

Prepared by Weston & Sampson

HydroCAD® 10.10-6a s/n 00455 © 2020 HydroCAD Software Solutions LLC

Type III 24-hr 25-year Rainfall=5.80"

Printed 11/5/2021

Page 88

Summary for Pond 4P: Detention Chambers sC 740

Inflow Area = 235,054 sf, 90.09% Impervious, Inflow Depth > 4.81" for 25-year event
 Inflow = 27.62 cfs @ 12.09 hrs, Volume= 94,303 cf
 Outflow = 13.65 cfs @ 12.24 hrs, Volume= 93,944 cf, Atten= 51%, Lag= 9.0 min
 Primary = 13.65 cfs @ 12.24 hrs, Volume= 93,944 cf
 Routed to Link 4L : Vernal Pool Wetlands

Routing by Dyn-Stor-Ind method, Time Span= 1.00-36.00 hrs, dt= 0.01 hrs
 Peak Elev= 129.97' @ 12.24 hrs Surf.Area= 14,134 sf Storage= 21,799 cf

Plug-Flow detention time= 78.2 min calculated for 93,944 cf (100% of inflow)
 Center-of-Mass det. time= 75.6 min (845.5 - 769.8)

Volume	Invert	Avail.Storage	Storage Description
#1A	127.76'	12,437 cf	120.25'W x 117.54'L x 3.50'H Field A 49,468 cf Overall - 18,376 cf Embedded = 31,092 cf x 40.0% Voids
#2A	128.26'	18,376 cf	ADS_StormTech SC-740 +Cap x 400 Inside #1 Effective Size= 44.6"W x 30.0"H => 6.45 sf x 7.12'L = 45.9 cf Overall Size= 51.0"W x 30.0"H x 7.56'L with 0.44' Overlap 400 Chambers in 25 Rows
		30,813 cf	Total Available Storage

Storage Group A created with Chamber Wizard

Device	Routing	Invert	Outlet Devices
#1	Primary	127.66'	24.0" Round Culvert L= 92.0' CPP, projecting, no headwall, Ke= 0.900 Inlet / Outlet Invert= 127.66' / 127.15' S= 0.0055 '/' Cc= 0.900 n= 0.013 Corrugated PE, smooth interior, Flow Area= 3.14 sf
#2	Device 1	127.76'	4.0" Vert. Orifice/Grate C= 0.600 Limited to weir flow at low heads
#3	Device 1	128.39'	4.0' long x 0.5' breadth Broad-Crested Rectangular Weir Head (feet) 0.20 0.40 0.60 0.80 1.00 Coef. (English) 2.80 2.92 3.08 3.30 3.32

Primary OutFlow Max=13.65 cfs @ 12.24 hrs HW=129.97' TW=0.00' (Dynamic Tailwater)

- ↑ **1=Culvert** (Inlet Controls 13.65 cfs @ 4.34 fps)
- ↑ **2=Orifice/Grate** (Passes < 0.60 cfs potential flow)
- ↑ **3=Broad-Crested Rectangular Weir**(Passes < 26.28 cfs potential flow)

Pond 4P: Detention Chambers sC 740

Hydrograph

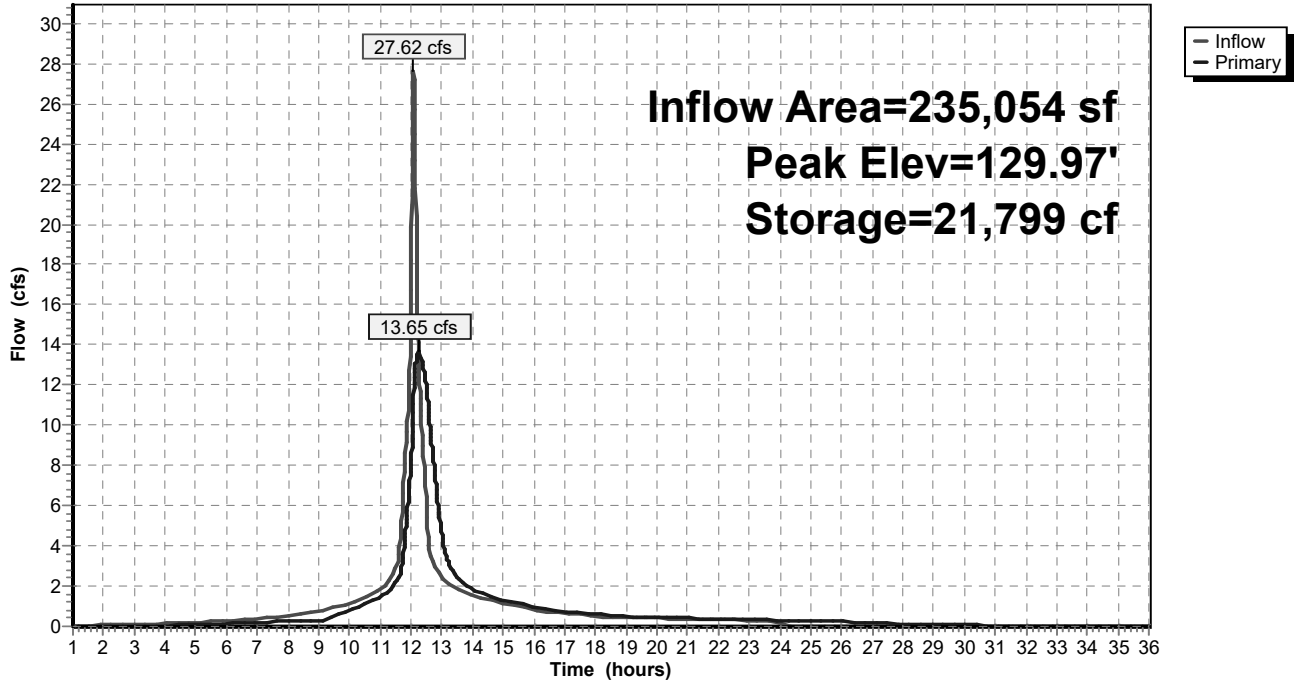

Summary for Link 1L: Leaching CB

Inflow Area = 9,774 sf, 0.00% Impervious, Inflow Depth = 0.05" for 25-year event
Inflow = 0.00 cfs @ 16.78 hrs, Volume= 43 cf
Primary = 0.00 cfs @ 16.78 hrs, Volume= 43 cf, Atten= 0%, Lag= 0.0 min

Primary outflow = Inflow, Time Span= 1.00-36.00 hrs, dt= 0.01 hrs

Link 1L: Leaching CB

Hydrograph

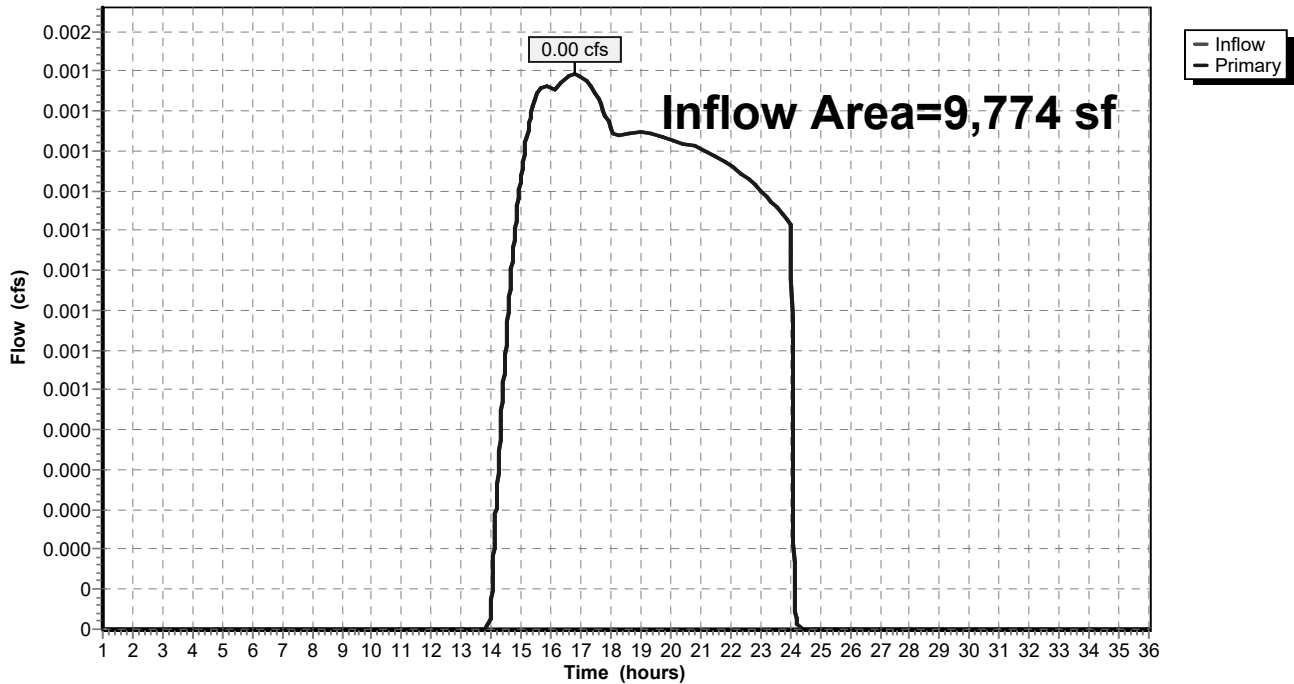

Summary for Link 2L: Isolated Wetlands

Inflow Area = 9,423 sf, 0.00% Impervious, Inflow Depth = 0.05" for 25-year event
Inflow = 0.00 cfs @ 16.78 hrs, Volume= 41 cf
Primary = 0.00 cfs @ 16.78 hrs, Volume= 41 cf, Atten= 0%, Lag= 0.0 min

Primary outflow = Inflow, Time Span= 1.00-36.00 hrs, dt= 0.01 hrs

Link 2L: Isolated Wetlands

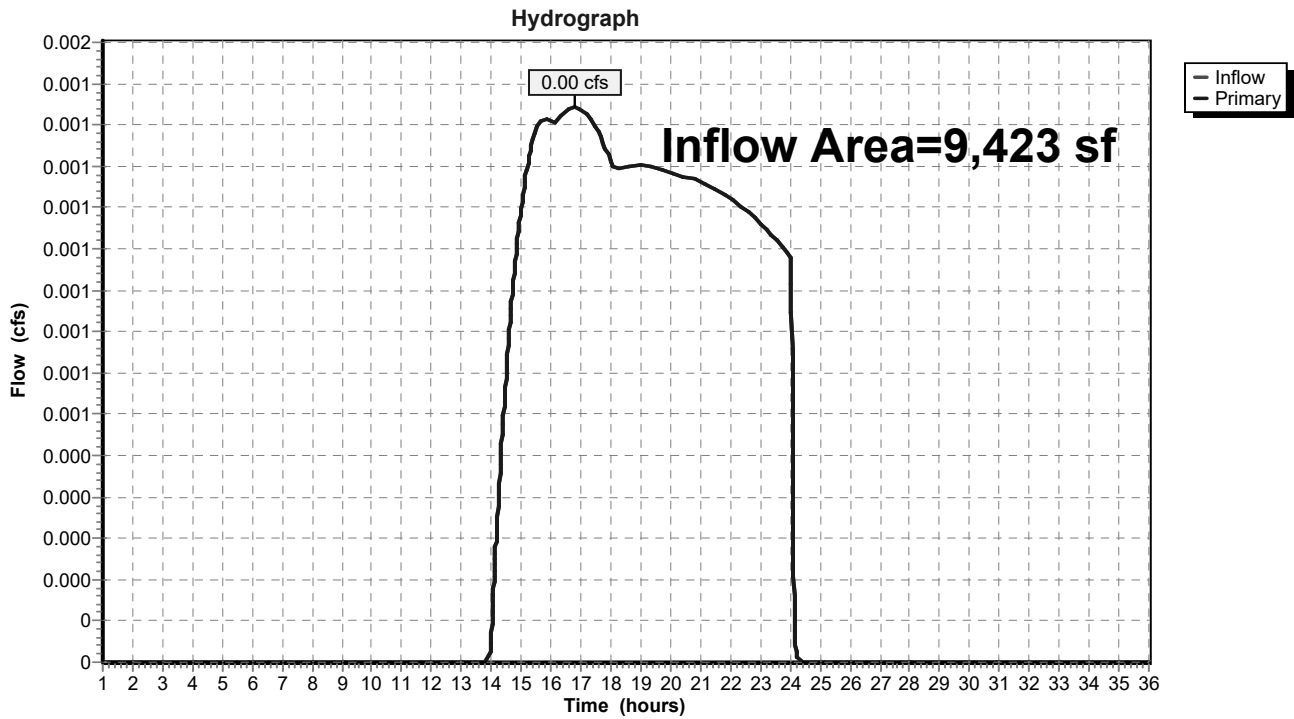

Spofford Post-Development

Prepared by Weston & Sampson

HydroCAD® 10.10-6a s/n 00455 © 2020 HydroCAD Software Solutions LLC

Type III 24-hr 25-year Rainfall=5.80"

Printed 11/5/2021

Page 92

Summary for Link 3L: Spofford Pond Wetlands

Inflow Area = 42,576 sf, 6.11% Impervious, Inflow Depth = 0.20" for 25-year event
Inflow = 0.06 cfs @ 12.37 hrs, Volume= 713 cf
Primary = 0.06 cfs @ 12.37 hrs, Volume= 713 cf, Atten= 0%, Lag= 0.0 min

Primary outflow = Inflow, Time Span= 1.00-36.00 hrs, dt= 0.01 hrs

Link 3L: Spofford Pond Wetlands

Hydrograph

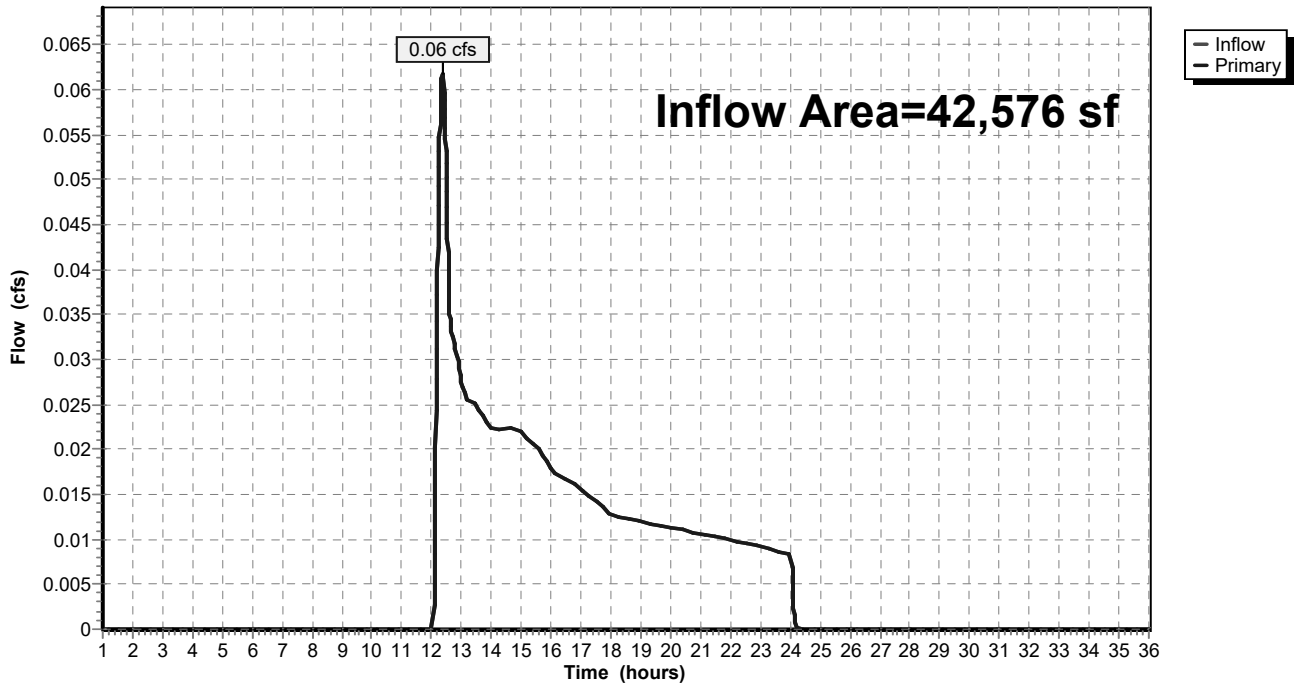

Spofford Post-Development

Prepared by Weston & Sampson

HydroCAD® 10.10-6a s/n 00455 © 2020 HydroCAD Software Solutions LLC

Type III 24-hr 25-year Rainfall=5.80"

Printed 11/5/2021

Page 93

Summary for Link 4L: Vernal Pool Wetlands

Inflow Area = 245,744 sf, 86.33% Impervious, Inflow Depth > 4.59" for 25-year event
Inflow = 13.65 cfs @ 12.24 hrs, Volume= 94,066 cf
Primary = 13.65 cfs @ 12.24 hrs, Volume= 94,066 cf, Atten= 0%, Lag= 0.0 min
Routed to nonexistent node 25L

Primary outflow = Inflow, Time Span= 1.00-36.00 hrs, dt= 0.01 hrs

Link 4L: Vernal Pool Wetlands

Hydrograph

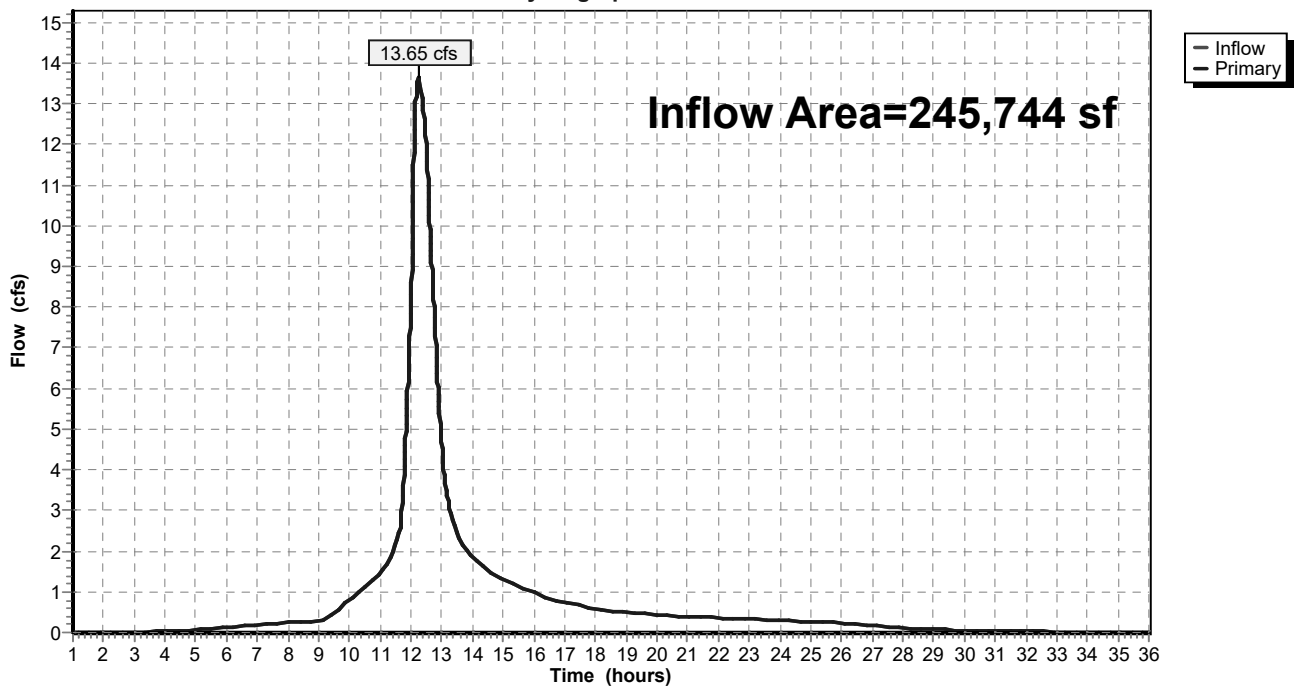

Spofford Post-Development

Prepared by Weston & Sampson

HydroCAD® 10.10-6a s/n 00455 © 2020 HydroCAD Software Solutions LLC

Type III 24-hr 50-year Rainfall=7.10"

Printed 11/5/2021

Page 94

Time span=1.00-36.00 hrs, dt=0.01 hrs, 3501 points
Runoff by SCS TR-20 method, UH=SCS, Weighted-CN
Reach routing by Dyn-Stor-Ind method - Pond routing by Dyn-Stor-Ind method

Subcatchment1S: Roof	Runoff Area=71,161 sf 100.00% Impervious Runoff Depth>6.86" Tc=6.0 min CN=98 Runoff=11.38 cfs 40,671 cf
Subcatchment2S: Sub 2	Runoff Area=9,774 sf 0.00% Impervious Runoff Depth=0.23" Tc=6.0 min CN=30 Runoff=0.01 cfs 187 cf
Subcatchment3S: Sub 3	Runoff Area=24,730 sf 73.09% Impervious Runoff Depth=4.79" Tc=6.0 min CN=80 Runoff=3.15 cfs 9,865 cf
Subcatchment4S: Sub 4	Runoff Area=13,951 sf 62.30% Impervious Runoff Depth=3.91" Tc=6.0 min CN=72 Runoff=1.47 cfs 4,551 cf
Subcatchment5S: Sub 5	Runoff Area=10,142 sf 79.94% Impervious Runoff Depth=5.23" Tc=6.0 min CN=84 Runoff=1.39 cfs 4,424 cf
Subcatchment6S: Sub 6	Runoff Area=18,754 sf 13.86% Impervious Runoff Depth=0.80" Tc=6.0 min CN=39 Runoff=0.20 cfs 1,257 cf
Subcatchment7S: Sub 7	Runoff Area=4,674 sf 100.00% Impervious Runoff Depth>6.86" Tc=6.0 min CN=98 Runoff=0.75 cfs 2,671 cf
Subcatchment8S: Sub 8	Runoff Area=23,822 sf 0.00% Impervious Runoff Depth=0.23" Tc=6.0 min CN=30 Runoff=0.02 cfs 456 cf
Subcatchment9S: Sub 9	Runoff Area=9,379 sf 95.68% Impervious Runoff Depth=6.51" Tc=6.0 min CN=95 Runoff=1.48 cfs 5,084 cf
Subcatchment10S: Sub 10	Runoff Area=18,532 sf 69.05% Impervious Runoff Depth=4.46" Tc=6.0 min CN=77 Runoff=2.21 cfs 6,881 cf
Subcatchment11S: Sub 11	Runoff Area=6,808 sf 98.43% Impervious Runoff Depth>6.74" Tc=6.0 min CN=97 Runoff=1.08 cfs 3,825 cf
Subcatchment12S: Sub 12	Runoff Area=5,470 sf 0.00% Impervious Runoff Depth=0.23" Tc=6.0 min CN=30 Runoff=0.00 cfs 105 cf
Subcatchment13S: Sub 13	Runoff Area=3,318 sf 87.70% Impervious Runoff Depth=5.92" Tc=6.0 min CN=90 Runoff=0.50 cfs 1,637 cf
Subcatchment14S: Sub 14	Runoff Area=3,898 sf 96.02% Impervious Runoff Depth=6.51" Tc=6.0 min CN=95 Runoff=0.61 cfs 2,113 cf
Subcatchment15S: Sub 15	Runoff Area=46,388 sf 96.62% Impervious Runoff Depth=6.62" Tc=6.0 min CN=96 Runoff=7.35 cfs 25,604 cf
Subcatchment16S: Sub 16	Runoff Area=11,222 sf 92.68% Impervious Runoff Depth=6.27" Tc=6.0 min CN=93 Runoff=1.74 cfs 5,864 cf

Spofford Post-Development

Prepared by Weston & Sampson

HydroCAD® 10.10-6a s/n 00455 © 2020 HydroCAD Software Solutions LLC

Type III 24-hr 50-year Rainfall=7.10"

Printed 11/5/2021

Page 95

Subcatchment 17S: Sub 17

Runoff Area=10,851 sf 98.57% Impervious Runoff Depth>6.74"
Tc=6.0 min CN=97 Runoff=1.73 cfs 6,096 cf

Subcatchment 18S: Sub 18

Runoff Area=10,690 sf 3.71% Impervious Runoff Depth=0.40"
Tc=6.0 min CN=33 Runoff=0.03 cfs 353 cf

Subcatchment 19S: Sub 19

Runoff Area=3,953 sf 0.00% Impervious Runoff Depth=0.23"
Tc=6.0 min CN=30 Runoff=0.00 cfs 76 cf

Pond 3P: Sediment Forebay

Peak Elev=133.96' Storage=925 cf Inflow=7.35 cfs 25,604 cf
Primary=7.21 cfs 25,230 cf Secondary=0.00 cfs 0 cf Outflow=7.21 cfs 25,230 cf

Pond 4P: Detention Chambers sC 740

Peak Elev=130.55' Storage=26,680 cf Inflow=34.62 cfs 118,913 cf
Outflow=16.40 cfs 118,546 cf

Link 1L: Leaching CB

Inflow=0.01 cfs 187 cf
Primary=0.01 cfs 187 cf

Link 2L: Isolated Wetlands

Inflow=0.01 cfs 180 cf
Primary=0.01 cfs 180 cf

Link 3L: Spofford Pond Wetlands

Inflow=0.20 cfs 1,713 cf
Primary=0.20 cfs 1,713 cf

Link 4L: Vernal Pool Wetlands

Inflow=16.42 cfs 118,899 cf
Primary=16.42 cfs 118,899 cf

Total Runoff Area = 307,517 sf Runoff Volume = 121,721 cf Average Runoff Depth = 4.75"
30.17% Pervious = 92,770 sf 69.83% Impervious = 214,747 sf

Spofford Post-Development

Prepared by Weston & Sampson

HydroCAD® 10.10-6a s/n 00455 © 2020 HydroCAD Software Solutions LLC

Type III 24-hr 50-year Rainfall=7.10"

Printed 11/5/2021

Page 96

Summary for Subcatchment 1S: Roof

Runoff = 11.38 cfs @ 12.08 hrs, Volume= 40,671 cf, Depth> 6.86"
Routed to Pond 4P : Detention Chambers sC 740

Runoff by SCS TR-20 method, UH=SCS, Weighted-CN, Time Span= 1.00-36.00 hrs, dt= 0.01 hrs
Type III 24-hr 50-year Rainfall=7.10"

Area (sf)	CN	Description
71,161	98	Roofs, HSG A
71,161		100.00% Impervious Area

Tc (min)	Length (feet)	Slope (ft/ft)	Velocity (ft/sec)	Capacity (cfs)	Description
6.0					Direct Entry,

Subcatchment 1S: Roof

Hydrograph

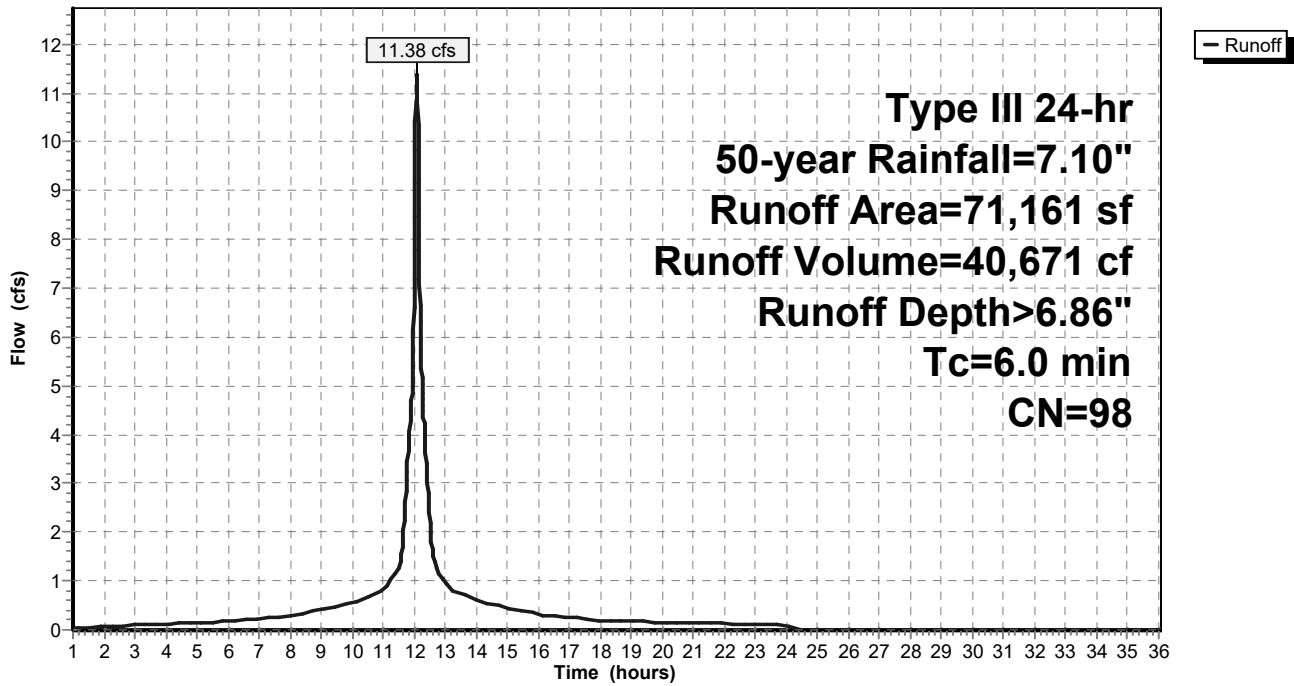

Spofford Post-Development

Prepared by Weston & Sampson

HydroCAD® 10.10-6a s/n 00455 © 2020 HydroCAD Software Solutions LLC

Type III 24-hr 50-year Rainfall=7.10"

Printed 11/5/2021

Page 97

Summary for Subcatchment 2S: Sub 2

Runoff = 0.01 cfs @ 13.70 hrs, Volume= 187 cf, Depth= 0.23"

Routed to Link 1L : Leaching CB

Runoff by SCS TR-20 method, UH=SCS, Weighted-CN, Time Span= 1.00-36.00 hrs, dt= 0.01 hrs
Type III 24-hr 50-year Rainfall=7.10"

Area (sf)	CN	Description
* 9,774	30	Grass
9,774		100.00% Pervious Area

Tc (min)	Length (feet)	Slope (ft/ft)	Velocity (ft/sec)	Capacity (cfs)	Description
6.0					Direct Entry,

Subcatchment 2S: Sub 2

Hydrograph

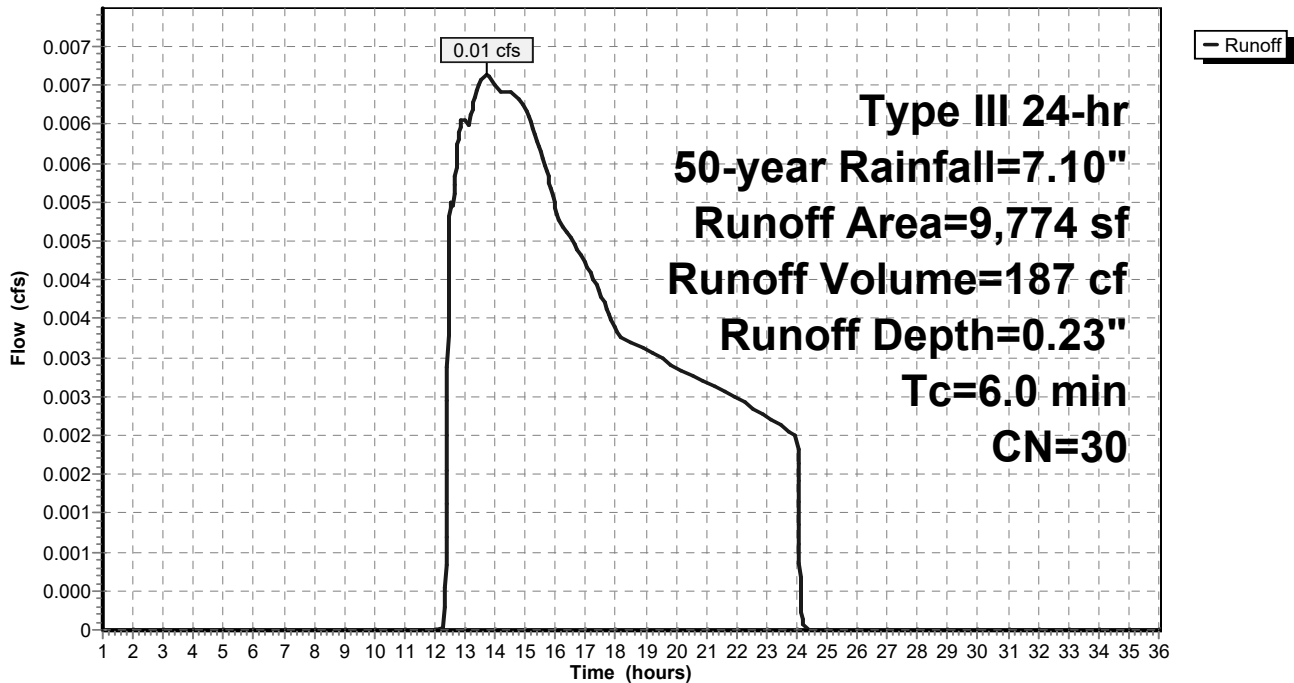

Spofford Post-Development

Prepared by Weston & Sampson

HydroCAD® 10.10-6a s/n 00455 © 2020 HydroCAD Software Solutions LLC

Type III 24-hr 50-year Rainfall=7.10"

Printed 11/5/2021

Page 98

Summary for Subcatchment 3S: Sub 3

Runoff = 3.15 cfs @ 12.09 hrs, Volume= 9,865 cf, Depth= 4.79"
 Routed to Pond 4P : Detention Chambers sC 740

Runoff by SCS TR-20 method, UH=SCS, Weighted-CN, Time Span= 1.00-36.00 hrs, dt= 0.01 hrs
 Type III 24-hr 50-year Rainfall=7.10"

Area (sf)	CN	Description
8,972	98	Paved parking, HSG A
* 9,104	98	Turf (impervious)
* 5,760	30	Grass
894	30	Woods, Good, HSG A
24,730	80	Weighted Average
6,654		26.91% Pervious Area
18,076		73.09% Impervious Area

Tc (min)	Length (feet)	Slope (ft/ft)	Velocity (ft/sec)	Capacity (cfs)	Description
6.0					Direct Entry,

Subcatchment 3S: Sub 3

Hydrograph

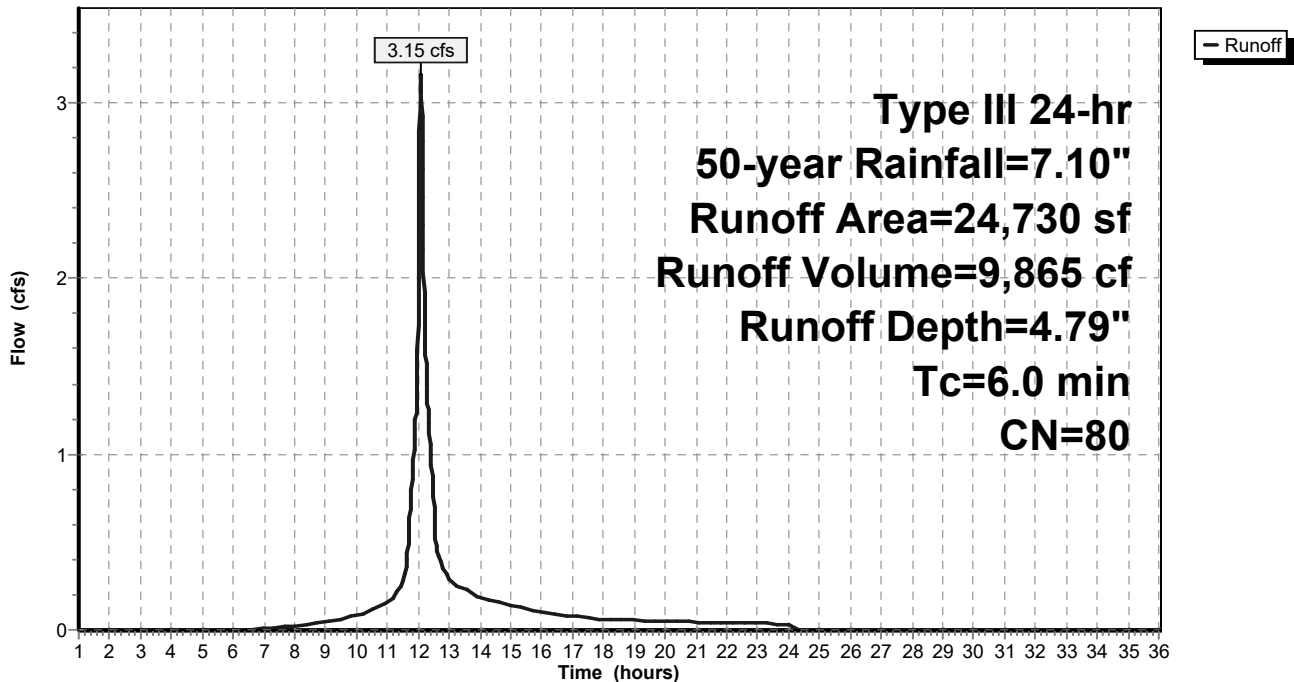

Spofford Post-Development

Prepared by Weston & Sampson

HydroCAD® 10.10-6a s/n 00455 © 2020 HydroCAD Software Solutions LLC

Type III 24-hr 50-year Rainfall=7.10"

Printed 11/5/2021

Page 99

Summary for Subcatchment 4S: Sub 4

Runoff = 1.47 cfs @ 12.09 hrs, Volume= 4,551 cf, Depth= 3.91"
 Routed to Pond 4P : Detention Chambers sC 740

Runoff by SCS TR-20 method, UH=SCS, Weighted-CN, Time Span= 1.00-36.00 hrs, dt= 0.01 hrs
 Type III 24-hr 50-year Rainfall=7.10"

Area (sf)	CN	Description
8,691	98	Paved parking, HSG A
2,060	30	Woods, Good, HSG A
* 3,200	30	Grass
13,951	72	Weighted Average
5,260		37.70% Pervious Area
8,691		62.30% Impervious Area

Tc (min)	Length (feet)	Slope (ft/ft)	Velocity (ft/sec)	Capacity (cfs)	Description
6.0					Direct Entry,

Subcatchment 4S: Sub 4

Hydrograph

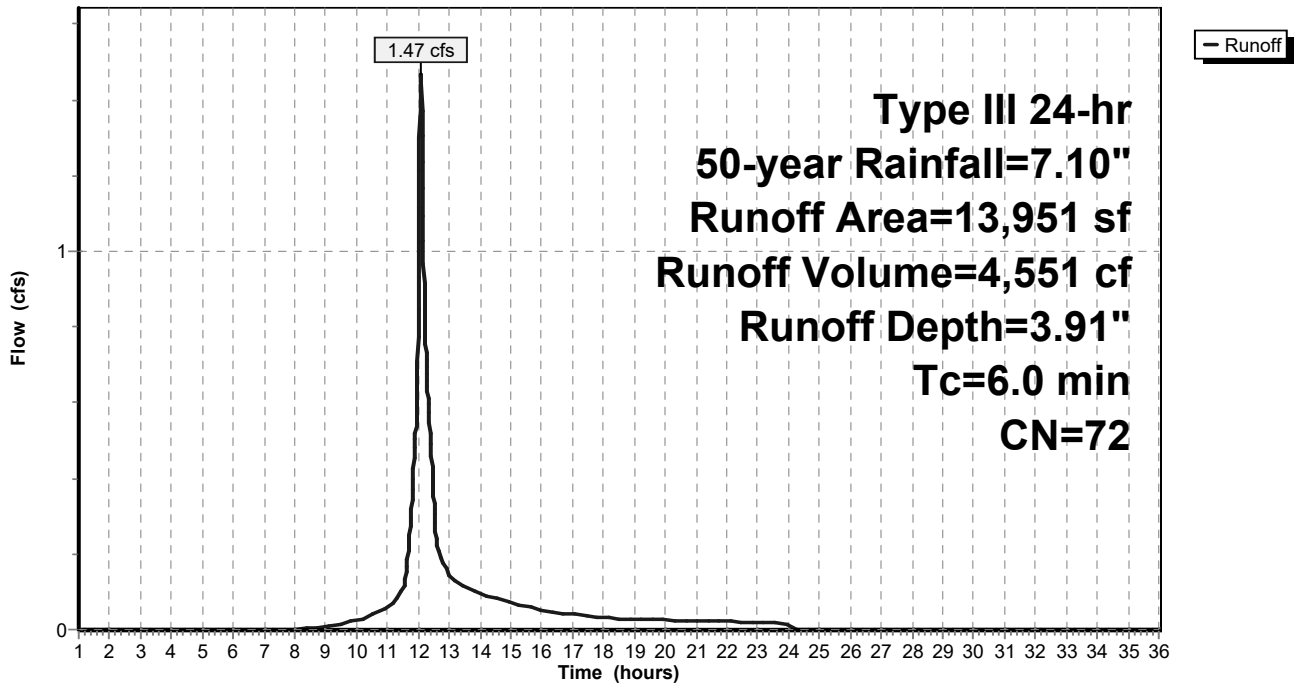

Spofford Post-Development

Prepared by Weston & Sampson

HydroCAD® 10.10-6a s/n 00455 © 2020 HydroCAD Software Solutions LLC

Type III 24-hr 50-year Rainfall=7.10"

Printed 11/5/2021

Page 100

Summary for Subcatchment 5S: Sub 5

Runoff = 1.39 cfs @ 12.09 hrs, Volume= 4,424 cf, Depth= 5.23"
Routed to Pond 4P : Detention Chambers sC 740

Runoff by SCS TR-20 method, UH=SCS, Weighted-CN, Time Span= 1.00-36.00 hrs, dt= 0.01 hrs
Type III 24-hr 50-year Rainfall=7.10"

Area (sf)	CN	Description
8,108	98	Paved parking, HSG A
* 2,034	30	Grass
10,142	84	Weighted Average
2,034		20.06% Pervious Area
8,108		79.94% Impervious Area

Tc (min)	Length (feet)	Slope (ft/ft)	Velocity (ft/sec)	Capacity (cfs)	Description
6.0					Direct Entry,

Subcatchment 5S: Sub 5

Hydrograph

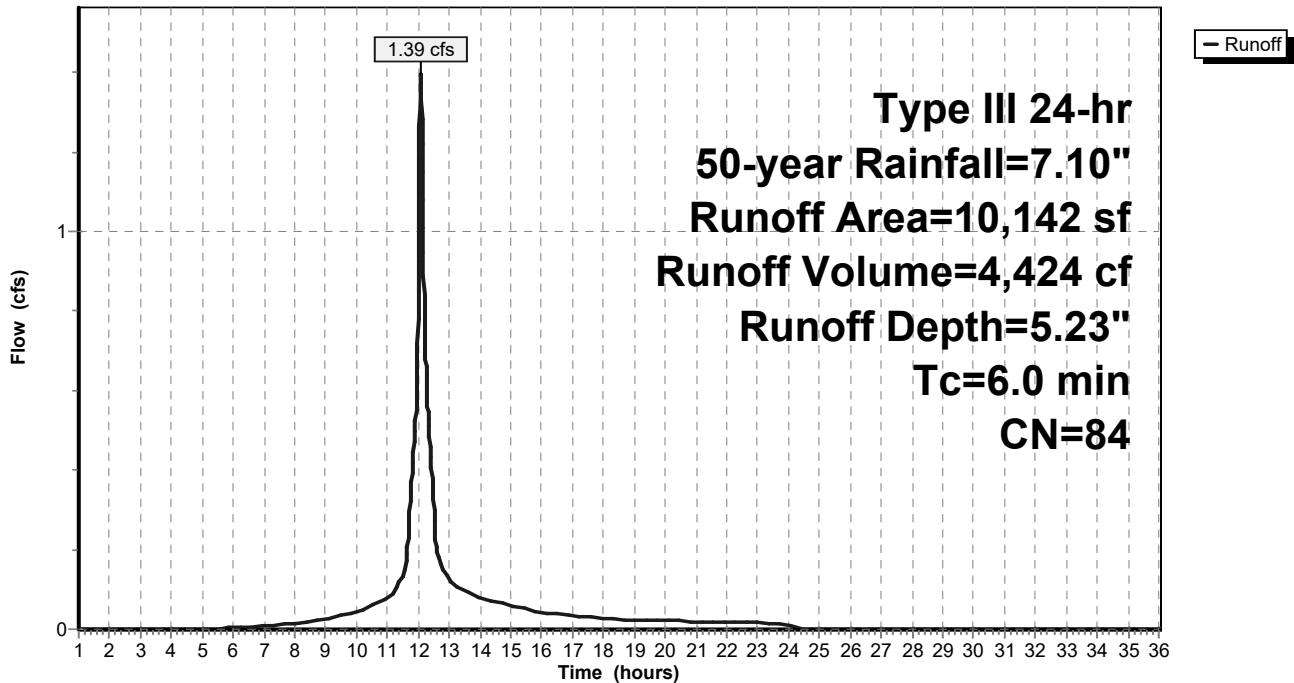

Spofford Post-Development

Prepared by Weston & Sampson

HydroCAD® 10.10-6a s/n 00455 © 2020 HydroCAD Software Solutions LLC

Type III 24-hr 50-year Rainfall=7.10"

Printed 11/5/2021

Page 101

Summary for Subcatchment 6S: Sub 6

Runoff = 0.20 cfs @ 12.14 hrs, Volume= 1,257 cf, Depth= 0.80"

Routed to Link 3L : Spofford Pond Wetlands

Runoff by SCS TR-20 method, UH=SCS, Weighted-CN, Time Span= 1.00-36.00 hrs, dt= 0.01 hrs
 Type III 24-hr 50-year Rainfall=7.10"

	Area (sf)	CN	Description
*	8,202	30	Grass
	7,952	30	Woods, Good, HSG A
	2,600	98	Paved parking, HSG A
	18,754	39	Weighted Average
	16,154		86.14% Pervious Area
	2,600		13.86% Impervious Area

Tc (min)	Length (feet)	Slope (ft/ft)	Velocity (ft/sec)	Capacity (cfs)	Description
6.0					Direct Entry,

Subcatchment 6S: Sub 6

Hydrograph

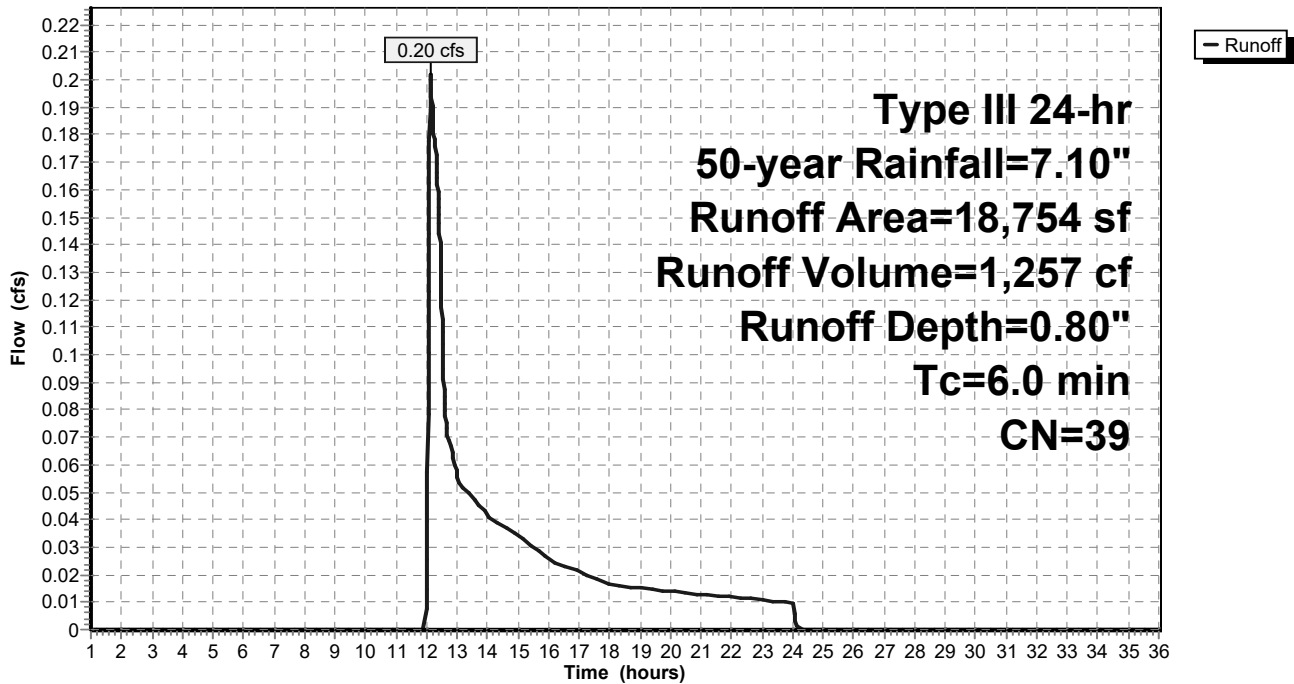

Spofford Post-Development

Prepared by Weston & Sampson

HydroCAD® 10.10-6a s/n 00455 © 2020 HydroCAD Software Solutions LLC

Type III 24-hr 50-year Rainfall=7.10"

Printed 11/5/2021

Page 102

Summary for Subcatchment 7S: Sub 7

Runoff = 0.75 cfs @ 12.08 hrs, Volume= 2,671 cf, Depth> 6.86"
Routed to Pond 4P : Detention Chambers sC 740

Runoff by SCS TR-20 method, UH=SCS, Weighted-CN, Time Span= 1.00-36.00 hrs, dt= 0.01 hrs
Type III 24-hr 50-year Rainfall=7.10"

Area (sf)	CN	Description
4,674	98	Paved parking, HSG A
4,674		100.00% Impervious Area

Tc (min)	Length (feet)	Slope (ft/ft)	Velocity (ft/sec)	Capacity (cfs)	Description
6.0					Direct Entry,

Subcatchment 7S: Sub 7

Hydrograph

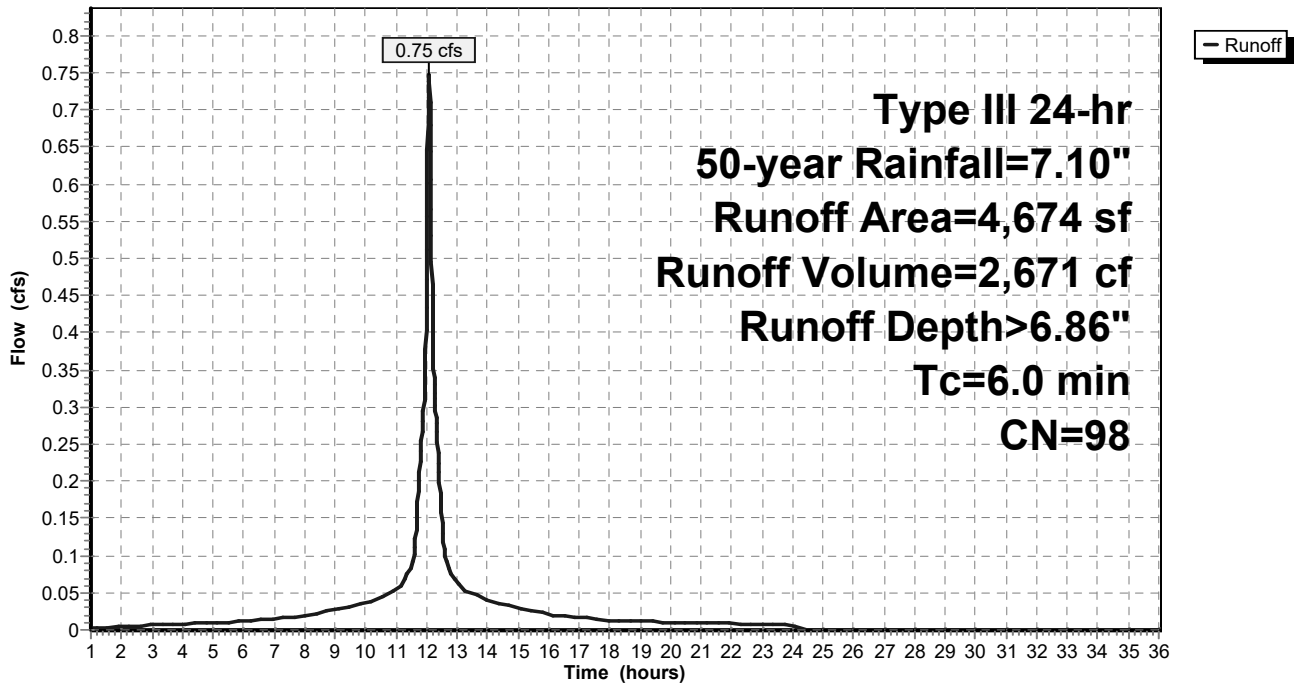

Spofford Post-Development

Prepared by Weston & Sampson

HydroCAD® 10.10-6a s/n 00455 © 2020 HydroCAD Software Solutions LLC

Type III 24-hr 50-year Rainfall=7.10"

Printed 11/5/2021

Page 103

Summary for Subcatchment 8S: Sub 8

Runoff = 0.02 cfs @ 13.70 hrs, Volume= 456 cf, Depth= 0.23"

Routed to Link 3L : Spofford Pond Wetlands

Runoff by SCS TR-20 method, UH=SCS, Weighted-CN, Time Span= 1.00-36.00 hrs, dt= 0.01 hrs
 Type III 24-hr 50-year Rainfall=7.10"

Area (sf)	CN	Description
* 23,822	30	Grass
23,822		100.00% Pervious Area

Tc (min)	Length (feet)	Slope (ft/ft)	Velocity (ft/sec)	Capacity (cfs)	Description
6.0					Direct Entry,

Subcatchment 8S: Sub 8

Hydrograph

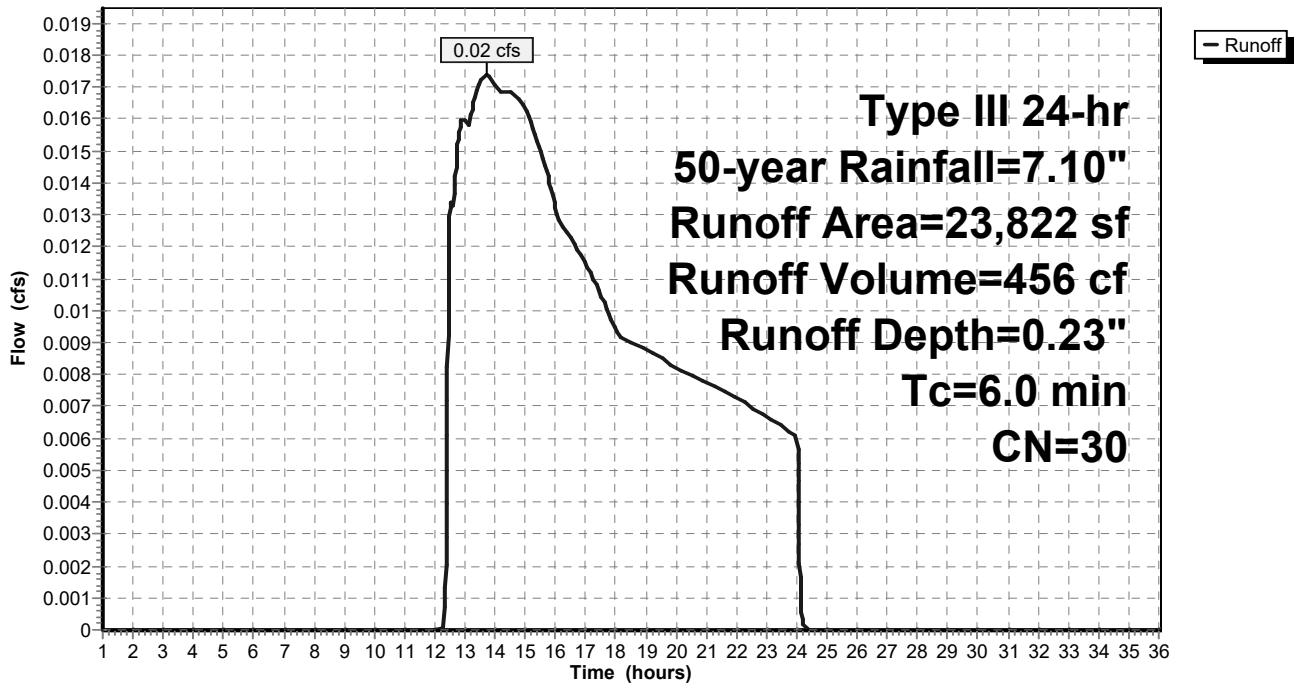

Spofford Post-Development

Prepared by Weston & Sampson

HydroCAD® 10.10-6a s/n 00455 © 2020 HydroCAD Software Solutions LLC

Type III 24-hr 50-year Rainfall=7.10"

Printed 11/5/2021

Page 104

Summary for Subcatchment 9S: Sub 9

Runoff = 1.48 cfs @ 12.08 hrs, Volume= 5,084 cf, Depth= 6.51"
Routed to Pond 4P : Detention Chambers sC 740

Runoff by SCS TR-20 method, UH=SCS, Weighted-CN, Time Span= 1.00-36.00 hrs, dt= 0.01 hrs
Type III 24-hr 50-year Rainfall=7.10"

Area (sf)	CN	Description
8,974	98	Paved parking, HSG A
* 405	30	Grass
9,379	95	Weighted Average
405		4.32% Pervious Area
8,974		95.68% Impervious Area

Tc (min)	Length (feet)	Slope (ft/ft)	Velocity (ft/sec)	Capacity (cfs)	Description
6.0					Direct Entry,

Subcatchment 9S: Sub 9

Hydrograph

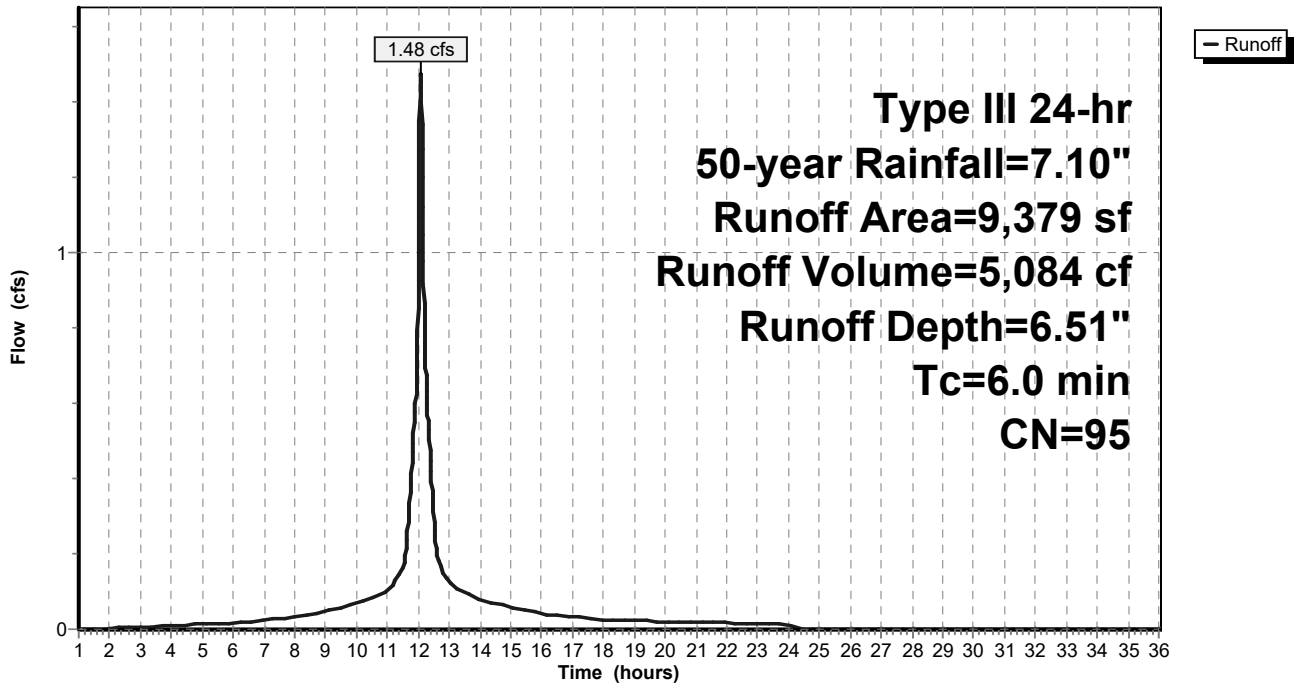

Spofford Post-Development

Prepared by Weston & Sampson

HydroCAD® 10.10-6a s/n 00455 © 2020 HydroCAD Software Solutions LLC

Type III 24-hr 50-year Rainfall=7.10"

Printed 11/5/2021

Page 105

Summary for Subcatchment 10S: Sub 10

Runoff = 2.21 cfs @ 12.09 hrs, Volume= 6,881 cf, Depth= 4.46"
Routed to Pond 4P : Detention Chambers sC 740

Runoff by SCS TR-20 method, UH=SCS, Weighted-CN, Time Span= 1.00-36.00 hrs, dt= 0.01 hrs
Type III 24-hr 50-year Rainfall=7.10"

Area (sf)	CN	Description
12,796	98	Paved parking, HSG A
424	30	Woods, Good, HSG A
* 5,312	30	Grass
18,532	77	Weighted Average
5,736		30.95% Pervious Area
12,796		69.05% Impervious Area

Tc (min)	Length (feet)	Slope (ft/ft)	Velocity (ft/sec)	Capacity (cfs)	Description
6.0					Direct Entry,

Subcatchment 10S: Sub 10

Hydrograph

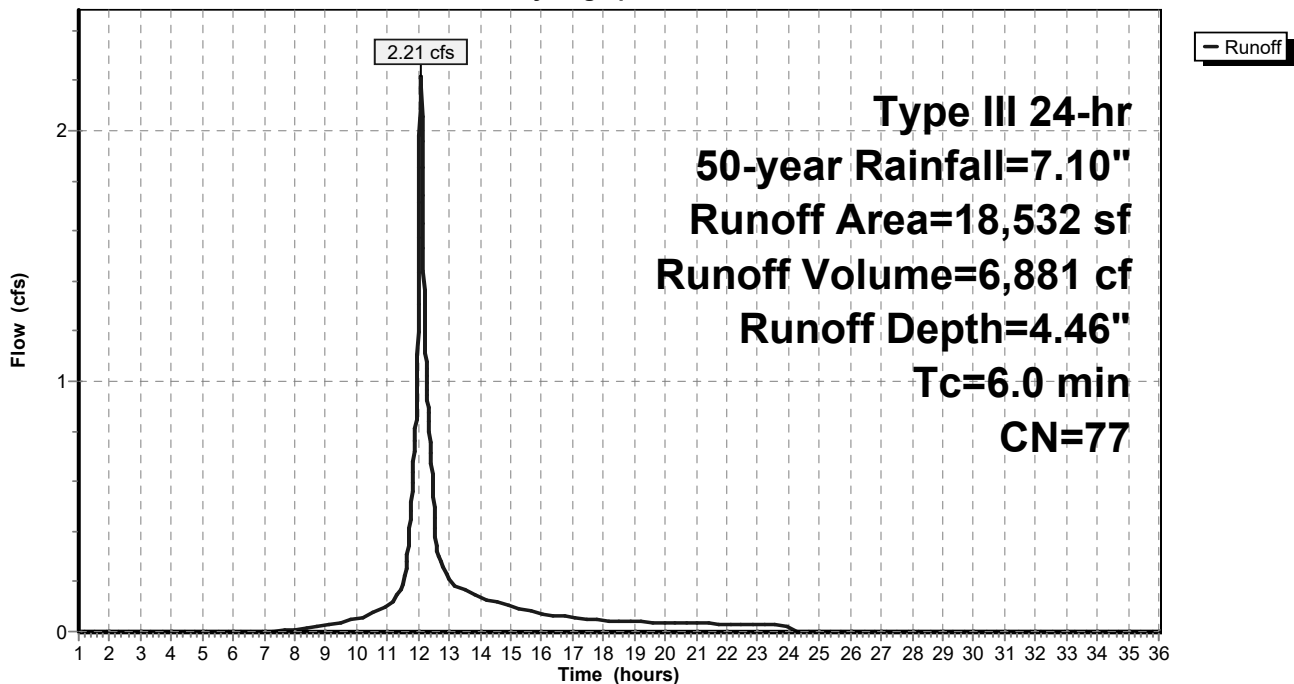

Spofford Post-Development

Prepared by Weston & Sampson

HydroCAD® 10.10-6a s/n 00455 © 2020 HydroCAD Software Solutions LLC

Type III 24-hr 50-year Rainfall=7.10"

Printed 11/5/2021

Page 106

Summary for Subcatchment 11S: Sub 11

Runoff = 1.08 cfs @ 12.08 hrs, Volume= 3,825 cf, Depth> 6.74"
 Routed to Pond 4P : Detention Chambers sC 740

Runoff by SCS TR-20 method, UH=SCS, Weighted-CN, Time Span= 1.00-36.00 hrs, dt= 0.01 hrs
 Type III 24-hr 50-year Rainfall=7.10"

Area (sf)	CN	Description
6,701	98	Paved parking, HSG A
* 107	30	Grass
6,808	97	Weighted Average
107		1.57% Pervious Area
6,701		98.43% Impervious Area

Tc (min)	Length (feet)	Slope (ft/ft)	Velocity (ft/sec)	Capacity (cfs)	Description
6.0					Direct Entry,

Subcatchment 11S: Sub 11

Hydrograph

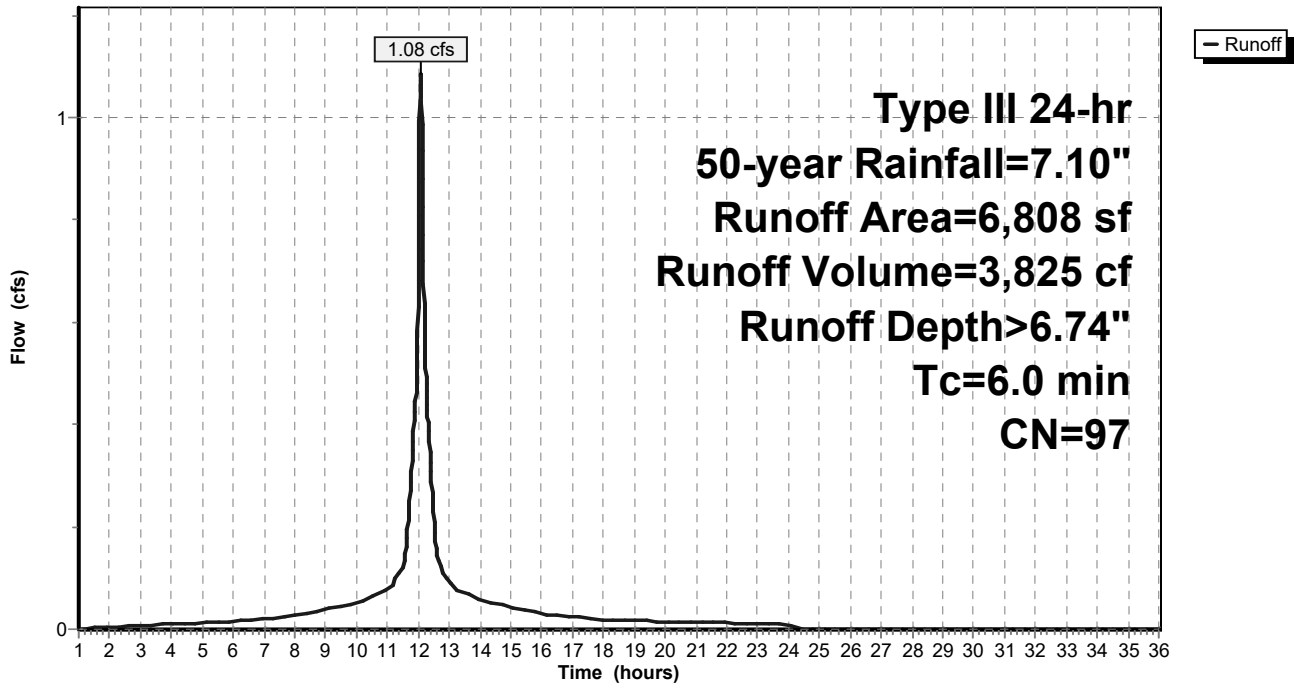

Spofford Post-Development

Prepared by Weston & Sampson

HydroCAD® 10.10-6a s/n 00455 © 2020 HydroCAD Software Solutions LLC

Type III 24-hr 50-year Rainfall=7.10"

Printed 11/5/2021

Page 107

Summary for Subcatchment 12S: Sub 12

Runoff = 0.00 cfs @ 13.70 hrs, Volume= 105 cf, Depth= 0.23"
 Routed to Link 2L : Isolated Wetlands

Runoff by SCS TR-20 method, UH=SCS, Weighted-CN, Time Span= 1.00-36.00 hrs, dt= 0.01 hrs
 Type III 24-hr 50-year Rainfall=7.10"

Area (sf)	CN	Description
* 5,470	30	Grass
5,470		100.00% Pervious Area

Tc (min)	Length (feet)	Slope (ft/ft)	Velocity (ft/sec)	Capacity (cfs)	Description
6.0					Direct Entry,

Subcatchment 12S: Sub 12

Hydrograph

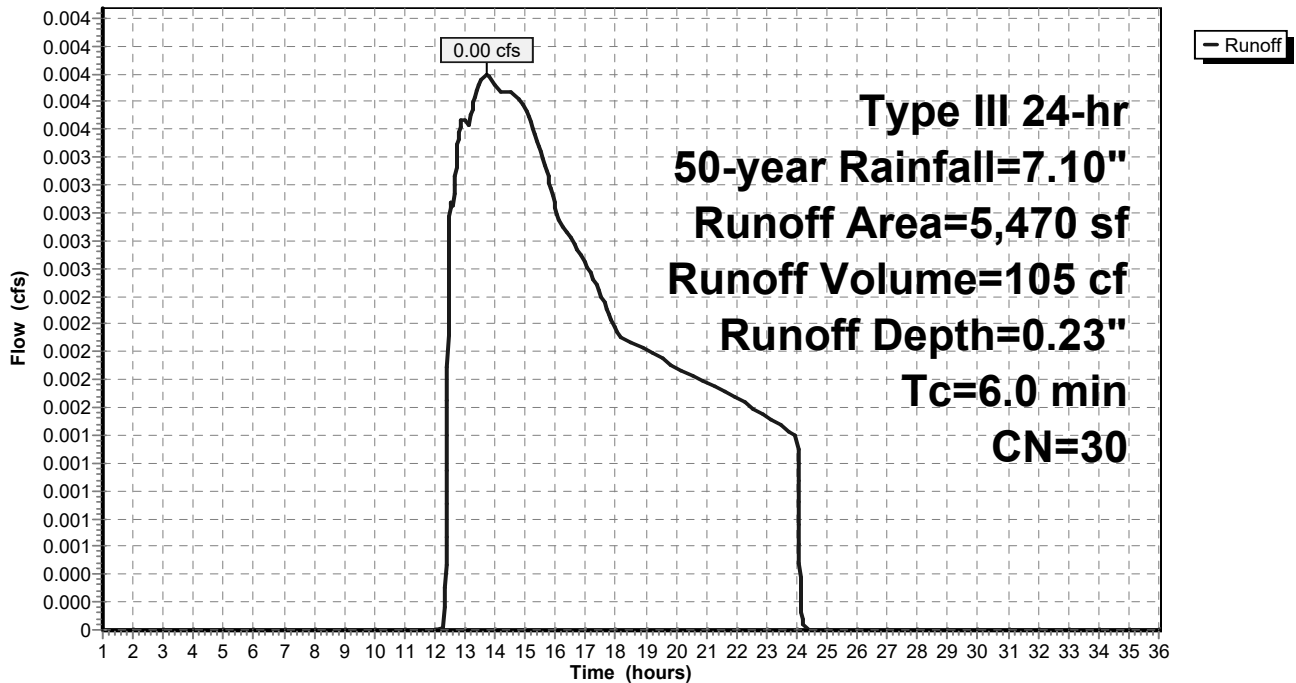

Spofford Post-Development

Prepared by Weston & Sampson

HydroCAD® 10.10-6a s/n 00455 © 2020 HydroCAD Software Solutions LLC

Type III 24-hr 50-year Rainfall=7.10"

Printed 11/5/2021

Page 108

Summary for Subcatchment 13S: Sub 13

Runoff = 0.50 cfs @ 12.08 hrs, Volume= 1,637 cf, Depth= 5.92"
 Routed to Pond 4P : Detention Chambers sC 740

Runoff by SCS TR-20 method, UH=SCS, Weighted-CN, Time Span= 1.00-36.00 hrs, dt= 0.01 hrs
 Type III 24-hr 50-year Rainfall=7.10"

Area (sf)	CN	Description
2,910	98	Paved parking, HSG A
* 408	30	Grass
3,318	90	Weighted Average
408		12.30% Pervious Area
2,910		87.70% Impervious Area

Tc (min)	Length (feet)	Slope (ft/ft)	Velocity (ft/sec)	Capacity (cfs)	Description
6.0					Direct Entry,

Subcatchment 13S: Sub 13

Hydrograph

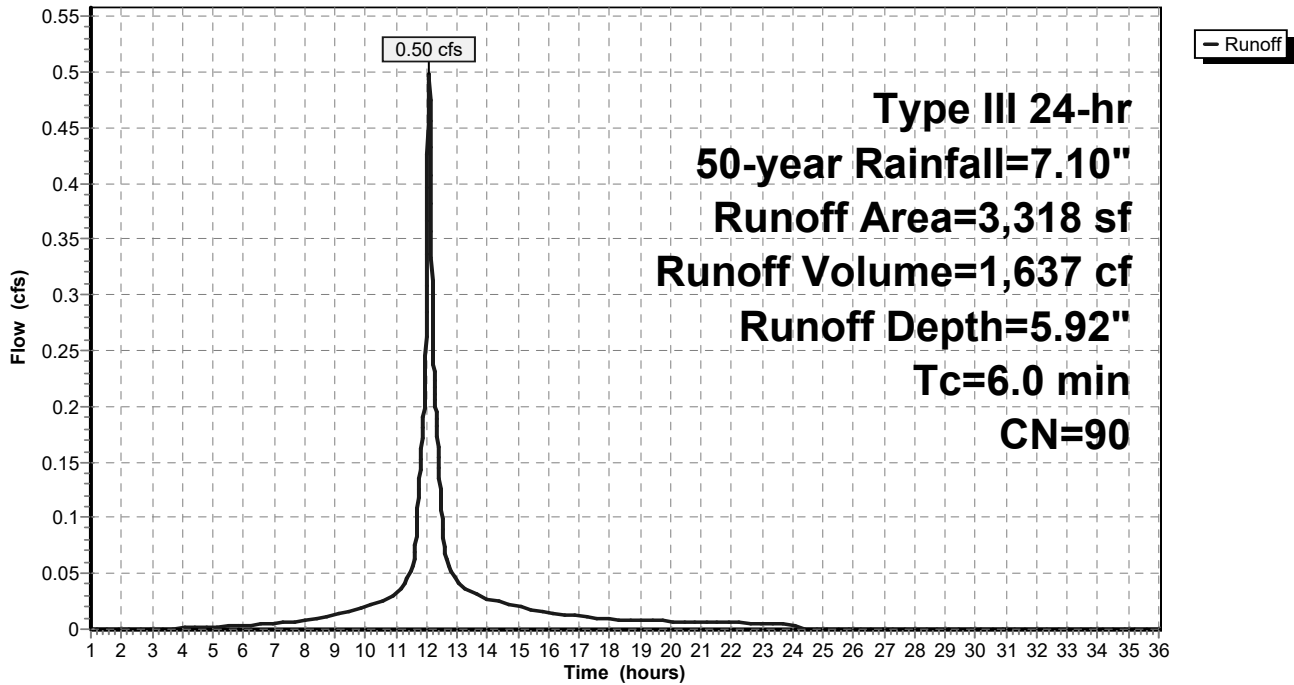

Spofford Post-Development

Prepared by Weston & Sampson

HydroCAD® 10.10-6a s/n 00455 © 2020 HydroCAD Software Solutions LLC

Type III 24-hr 50-year Rainfall=7.10"

Printed 11/5/2021

Page 109

Summary for Subcatchment 14S: Sub 14

Runoff = 0.61 cfs @ 12.08 hrs, Volume= 2,113 cf, Depth= 6.51"
Routed to Pond 4P : Detention Chambers sC 740

Runoff by SCS TR-20 method, UH=SCS, Weighted-CN, Time Span= 1.00-36.00 hrs, dt= 0.01 hrs
Type III 24-hr 50-year Rainfall=7.10"

Area (sf)	CN	Description
3,743	98	Paved parking, HSG A
* 155	30	Grass
3,898	95	Weighted Average
155		3.98% Pervious Area
3,743		96.02% Impervious Area

Tc (min)	Length (feet)	Slope (ft/ft)	Velocity (ft/sec)	Capacity (cfs)	Description
6.0					Direct Entry,

Subcatchment 14S: Sub 14

Hydrograph

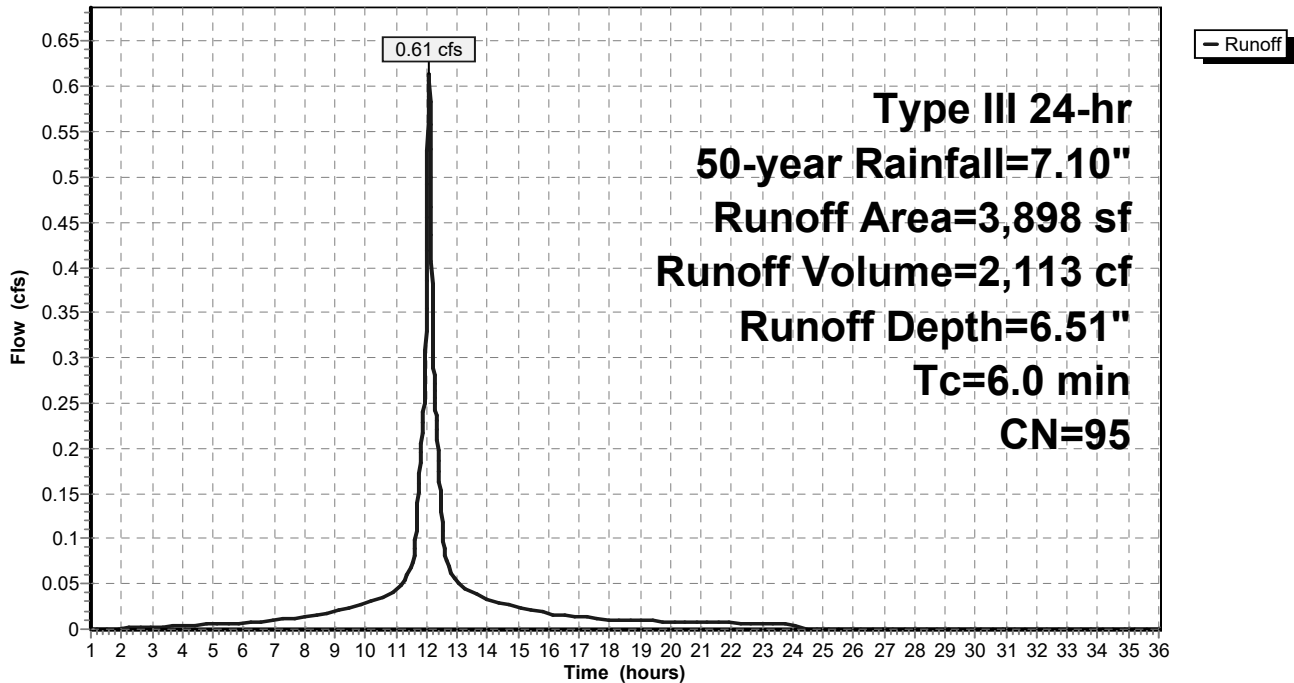

Spofford Post-Development

Prepared by Weston & Sampson

HydroCAD® 10.10-6a s/n 00455 © 2020 HydroCAD Software Solutions LLC

Type III 24-hr 50-year Rainfall=7.10"

Printed 11/5/2021

Page 110

Summary for Subcatchment 15S: Sub 15

Runoff = 7.35 cfs @ 12.08 hrs, Volume= 25,604 cf, Depth= 6.62"

Routed to Pond 3P : Sediment Forebay

Runoff by SCS TR-20 method, UH=SCS, Weighted-CN, Time Span= 1.00-36.00 hrs, dt= 0.01 hrs
Type III 24-hr 50-year Rainfall=7.10"

	Area (sf)	CN	Description
*	1,568	30	Grass
	44,820	98	Paved parking, HSG A
	46,388	96	Weighted Average
	1,568		3.38% Pervious Area
	44,820		96.62% Impervious Area

Tc (min)	Length (feet)	Slope (ft/ft)	Velocity (ft/sec)	Capacity (cfs)	Description
6.0					Direct Entry,

Subcatchment 15S: Sub 15

Hydrograph

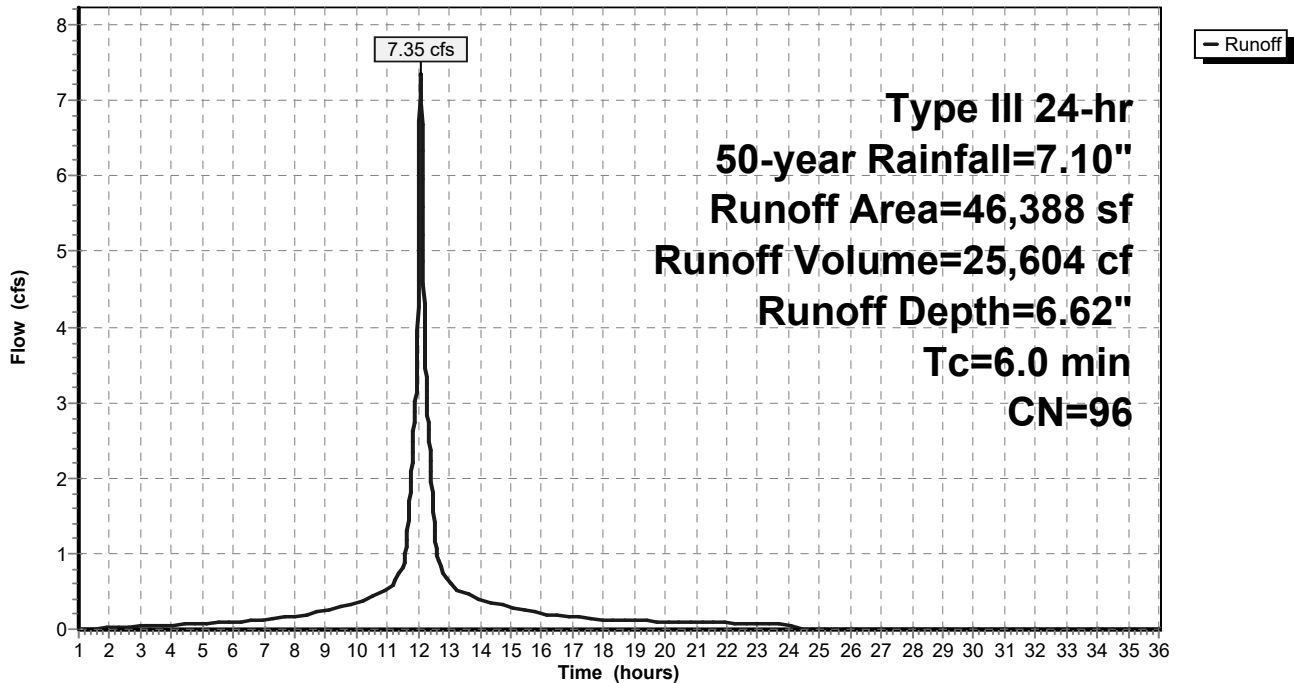

Spofford Post-Development

Prepared by Weston & Sampson

HydroCAD® 10.10-6a s/n 00455 © 2020 HydroCAD Software Solutions LLC

Type III 24-hr 50-year Rainfall=7.10"

Printed 11/5/2021

Page 111

Summary for Subcatchment 16S: Sub 16

Runoff = 1.74 cfs @ 12.08 hrs, Volume= 5,864 cf, Depth= 6.27"
 Routed to Pond 4P : Detention Chambers sC 740

Runoff by SCS TR-20 method, UH=SCS, Weighted-CN, Time Span= 1.00-36.00 hrs, dt= 0.01 hrs
 Type III 24-hr 50-year Rainfall=7.10"

Area (sf)	CN	Description
10,400	98	Paved parking, HSG A
* 822	30	Grass
11,222	93	Weighted Average
822		7.32% Pervious Area
10,400		92.68% Impervious Area

Tc (min)	Length (feet)	Slope (ft/ft)	Velocity (ft/sec)	Capacity (cfs)	Description
6.0					Direct Entry,

Subcatchment 16S: Sub 16

Hydrograph

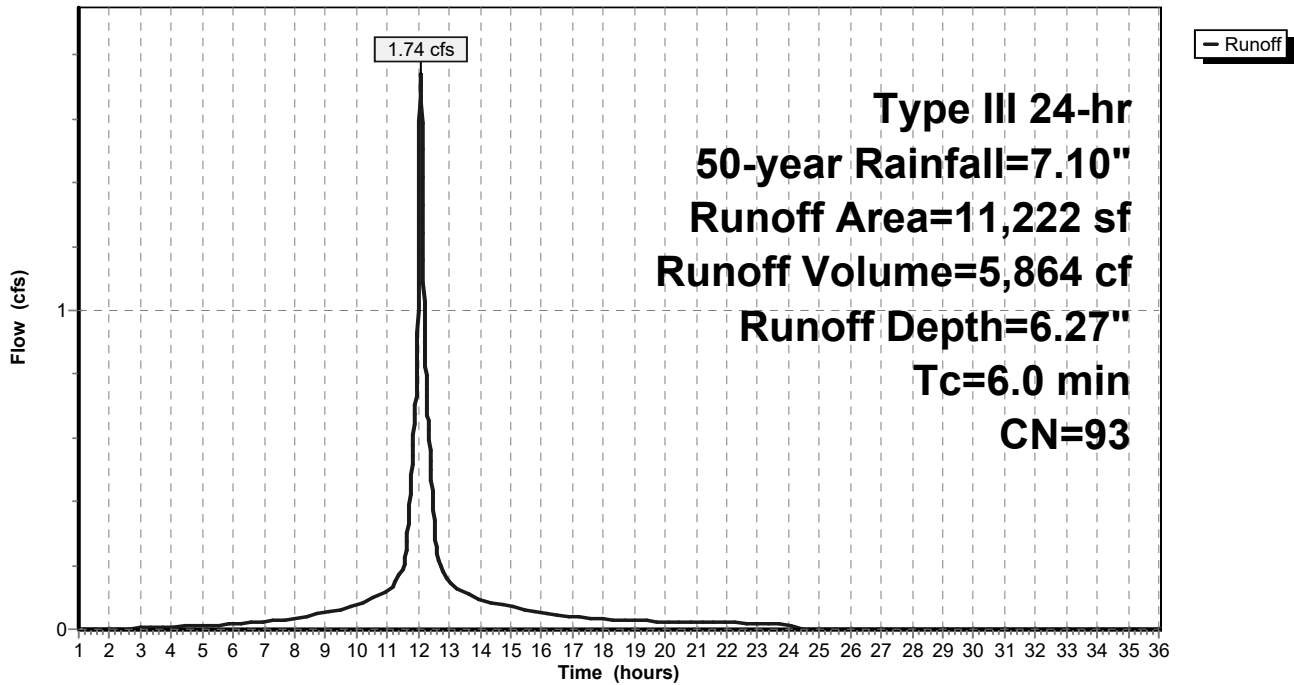

Spofford Post-Development

Prepared by Weston & Sampson

HydroCAD® 10.10-6a s/n 00455 © 2020 HydroCAD Software Solutions LLC

Type III 24-hr 50-year Rainfall=7.10"

Printed 11/5/2021

Page 112

Summary for Subcatchment 17S: Sub 17

Runoff = 1.73 cfs @ 12.08 hrs, Volume= 6,096 cf, Depth> 6.74"
Routed to Pond 4P : Detention Chambers sC 740

Runoff by SCS TR-20 method, UH=SCS, Weighted-CN, Time Span= 1.00-36.00 hrs, dt= 0.01 hrs
Type III 24-hr 50-year Rainfall=7.10"

Area (sf)	CN	Description
* 155	30	Grass
10,696	98	Paved parking, HSG A
10,851	97	Weighted Average
155		1.43% Pervious Area
10,696		98.57% Impervious Area

Tc (min)	Length (feet)	Slope (ft/ft)	Velocity (ft/sec)	Capacity (cfs)	Description
6.0					Direct Entry,

Subcatchment 17S: Sub 17

Hydrograph

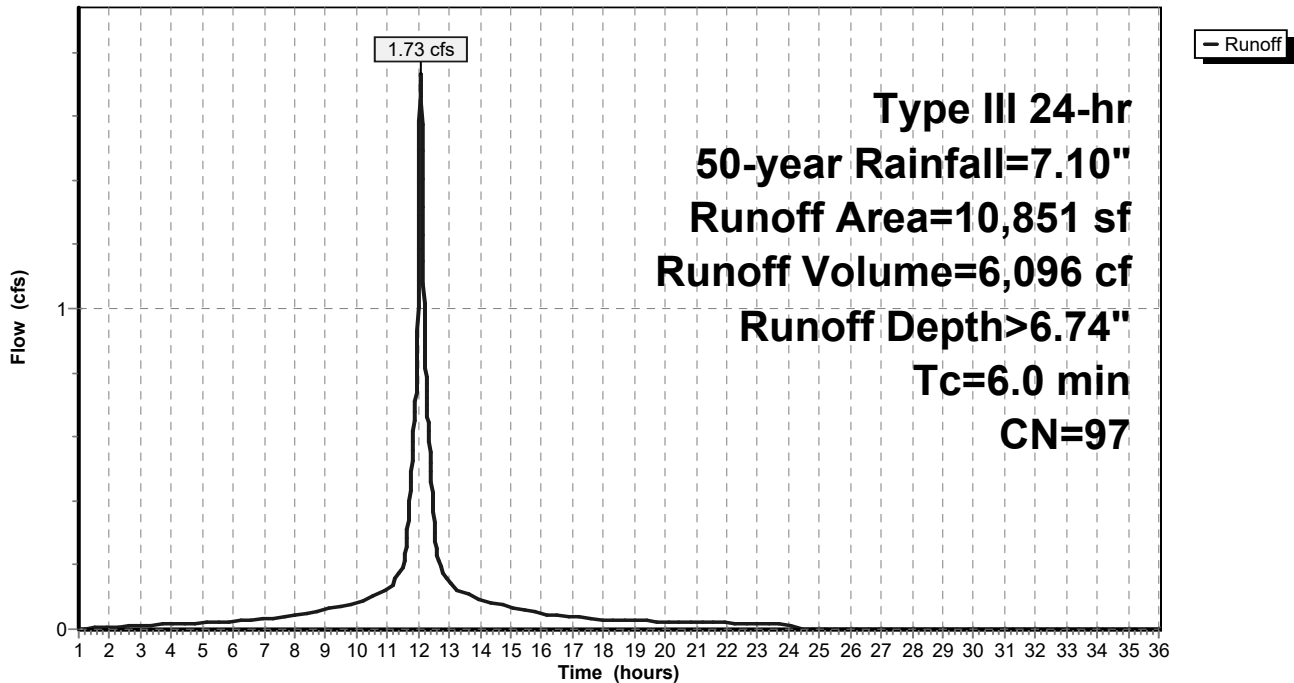

Spofford Post-Development

Prepared by Weston & Sampson

HydroCAD® 10.10-6a s/n 00455 © 2020 HydroCAD Software Solutions LLC

Type III 24-hr 50-year Rainfall=7.10"

Printed 11/5/2021

Page 113

Summary for Subcatchment 18S: Sub 18

Runoff = 0.03 cfs @ 12.40 hrs, Volume= 353 cf, Depth= 0.40"
 Routed to Link 4L : Vernal Pool Wetlands

Runoff by SCS TR-20 method, UH=SCS, Weighted-CN, Time Span= 1.00-36.00 hrs, dt= 0.01 hrs
 Type III 24-hr 50-year Rainfall=7.10"

	Area (sf)	CN	Description
*	5,866	30	Grass
	397	98	Paved parking, HSG A
	4,427	30	Woods, Good, HSG A
	10,690	33	Weighted Average
	10,293		96.29% Pervious Area
	397		3.71% Impervious Area

Tc (min)	Length (feet)	Slope (ft/ft)	Velocity (ft/sec)	Capacity (cfs)	Description
6.0					Direct Entry,

Subcatchment 18S: Sub 18

Hydrograph

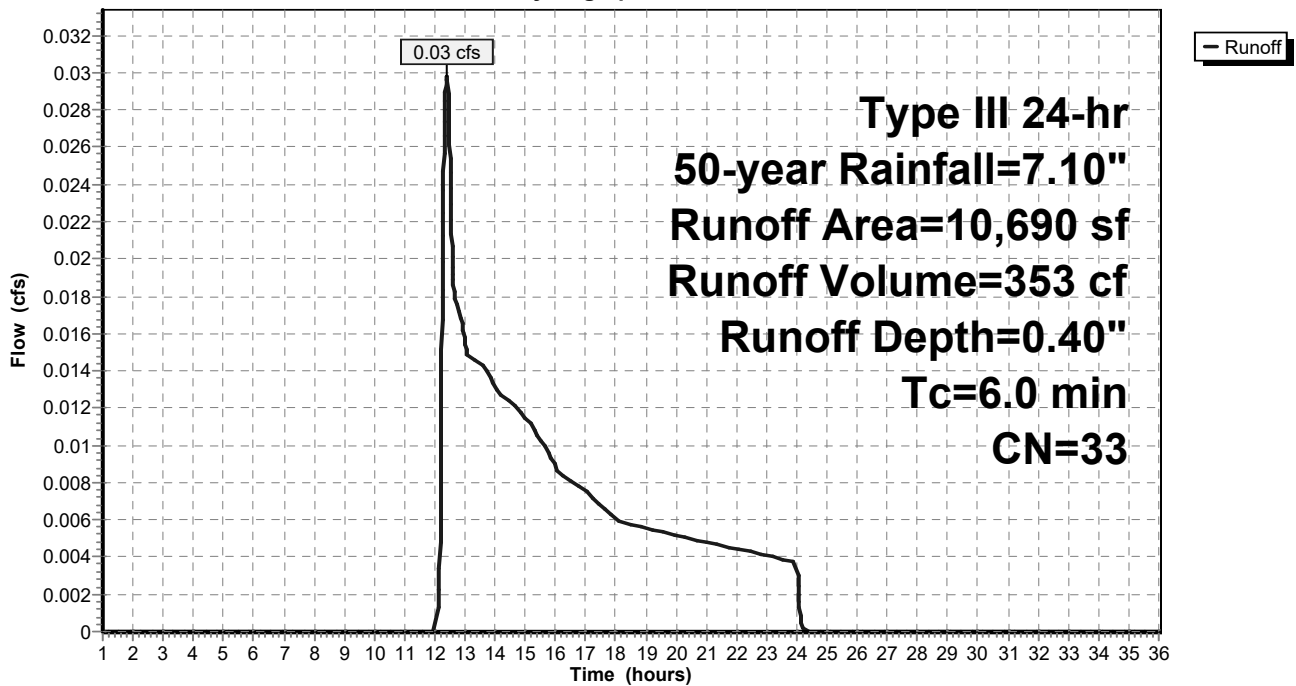

Spofford Post-Development

Prepared by Weston & Sampson

HydroCAD® 10.10-6a s/n 00455 © 2020 HydroCAD Software Solutions LLC

Type III 24-hr 50-year Rainfall=7.10"

Printed 11/5/2021

Page 114

Summary for Subcatchment 19S: Sub 19

Runoff = 0.00 cfs @ 13.70 hrs, Volume= 76 cf, Depth= 0.23"

Routed to Link 2L : Isolated Wetlands

Runoff by SCS TR-20 method, UH=SCS, Weighted-CN, Time Span= 1.00-36.00 hrs, dt= 0.01 hrs
Type III 24-hr 50-year Rainfall=7.10"

Area (sf)	CN	Description
* 3,953	30	Grass
3,953		100.00% Pervious Area

Tc (min)	Length (feet)	Slope (ft/ft)	Velocity (ft/sec)	Capacity (cfs)	Description
6.0					Direct Entry,

Subcatchment 19S: Sub 19

Hydrograph

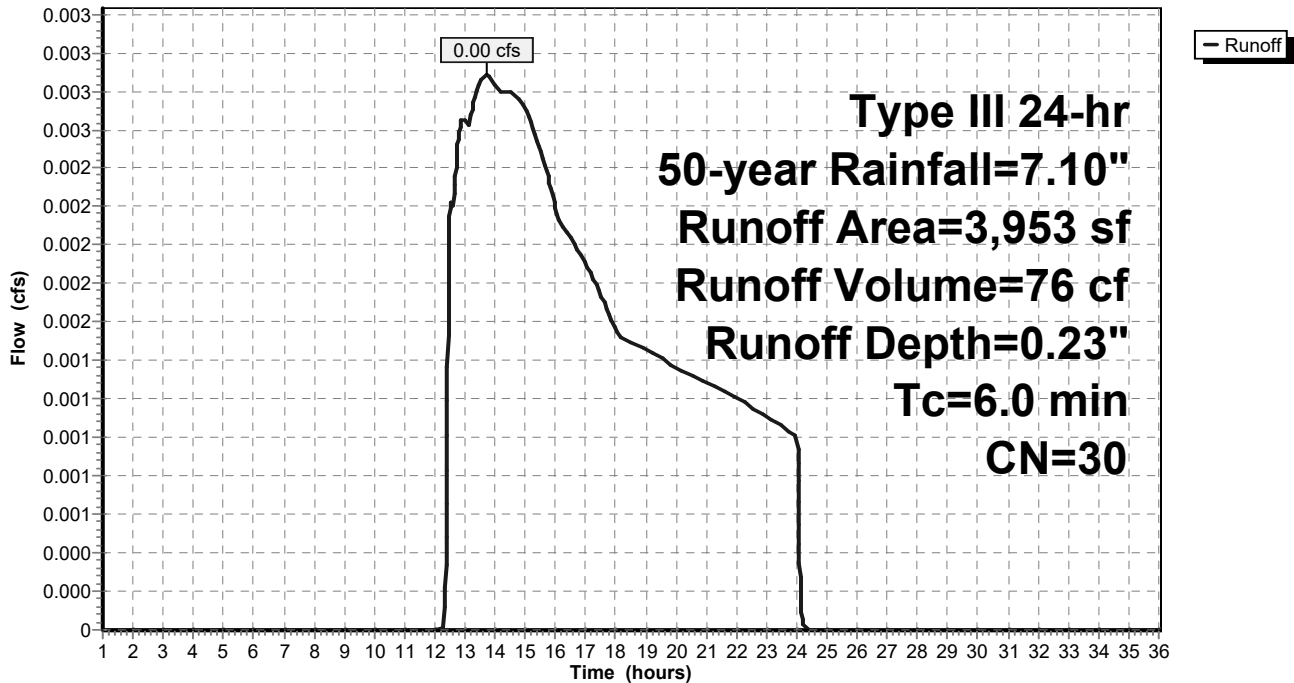

Spofford Post-Development

Prepared by Weston & Sampson

HydroCAD® 10.10-6a s/n 00455 © 2020 HydroCAD Software Solutions LLC

Type III 24-hr 50-year Rainfall=7.10"

Printed 11/5/2021

Page 115

Summary for Pond 3P: Sediment Forebay

Inflow Area = 46,388 sf, 96.62% Impervious, Inflow Depth = 6.62" for 50-year event
 Inflow = 7.35 cfs @ 12.08 hrs, Volume= 25,604 cf
 Outflow = 7.21 cfs @ 12.10 hrs, Volume= 25,230 cf, Atten= 2%, Lag= 1.0 min
 Primary = 7.21 cfs @ 12.10 hrs, Volume= 25,230 cf
 Routed to Pond 4P : Detention Chambers sC 740
 Secondary = 0.00 cfs @ 1.00 hrs, Volume= 0 cf
 Routed to Pond 4P : Detention Chambers sC 740

Routing by Dyn-Stor-Ind method, Time Span= 1.00-36.00 hrs, dt= 0.01 hrs
 Peak Elev= 133.96' @ 12.10 hrs Surf.Area= 1,274 sf Storage= 925 cf

Plug-Flow detention time= 20.4 min calculated for 25,230 cf (99% of inflow)
 Center-of-Mass det. time= 10.8 min (765.5 - 754.7)

Volume	Invert	Avail.Storage	Storage Description
#1	133.00'	979 cf	Custom Stage Data (Irregular) Listed below (Recalc)

Elevation (feet)	Surf.Area (sq-ft)	Perim. (feet)	Inc.Store (cubic-feet)	Cum.Store (cubic-feet)	Wet.Area (sq-ft)
133.00	687	186.0	0	0	687
134.00	1,304	215.0	979	979	1,634

Device	Routing	Invert	Outlet Devices
#1	Primary	128.65'	24.0" Round Culvert L= 29.0' CPP, projecting, no headwall, Ke= 0.900 Inlet / Outlet Invert= 128.65' / 128.50' S= 0.0052 '/' Cc= 0.900 n= 0.013 Corrugated PE, smooth interior, Flow Area= 3.14 sf
#2	Device 1	133.46'	24.0" Horiz. Orifice/Grate C= 0.600 Limited to weir flow at low heads
#3	Secondary	134.00'	215.0' long x 2.0' breadth Broad-Crested Rectangular Weir Head (feet) 0.20 0.40 0.60 0.80 1.00 1.20 1.40 1.60 1.80 2.00 2.50 3.00 3.50 Coef. (English) 2.54 2.61 2.61 2.60 2.66 2.70 2.77 2.89 2.88 2.85 3.07 3.20 3.32

Primary OutFlow Max=7.21 cfs @ 12.10 hrs HW=133.96' TW=129.99' (Dynamic Tailwater)

- ↑1=Culvert (Passes 7.21 cfs of 23.78 cfs potential flow)
- ↑2=Orifice/Grate (Weir Controls 7.21 cfs @ 2.31 fps)

Secondary OutFlow Max=0.00 cfs @ 1.00 hrs HW=133.00' TW=127.76' (Dynamic Tailwater)

- ↑3=Broad-Crested Rectangular Weir (Controls 0.00 cfs)

Pond 3P: Sediment Forebay

Hydrograph

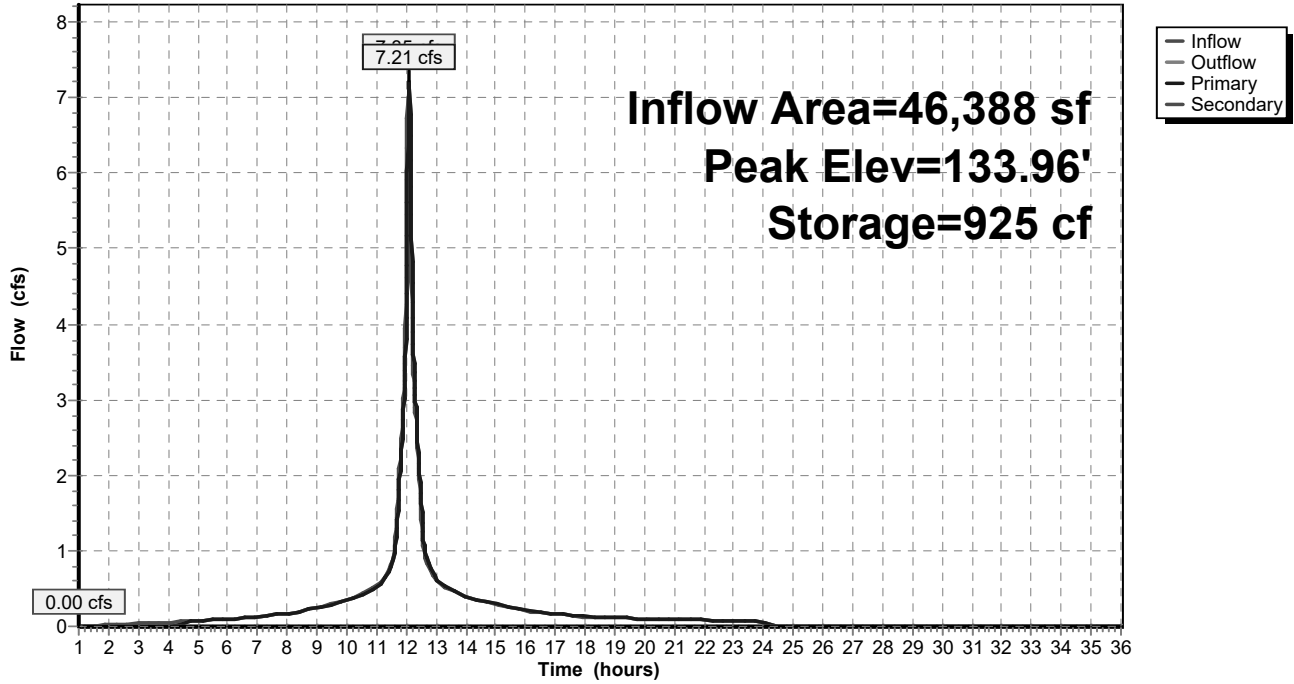

Spofford Post-Development

Prepared by Weston & Sampson

HydroCAD® 10.10-6a s/n 00455 © 2020 HydroCAD Software Solutions LLC

Type III 24-hr 50-year Rainfall=7.10"

Printed 11/5/2021

Page 117

Summary for Pond 4P: Detention Chambers sC 740

Inflow Area = 235,054 sf, 90.09% Impervious, Inflow Depth > 6.07" for 50-year event
 Inflow = 34.62 cfs @ 12.09 hrs, Volume= 118,913 cf
 Outflow = 16.40 cfs @ 12.25 hrs, Volume= 118,546 cf, Atten= 53%, Lag= 9.7 min
 Primary = 16.40 cfs @ 12.25 hrs, Volume= 118,546 cf
 Routed to Link 4L : Vernal Pool Wetlands

Routing by Dyn-Stor-Ind method, Time Span= 1.00-36.00 hrs, dt= 0.01 hrs
 Peak Elev= 130.55' @ 12.25 hrs Surf.Area= 14,134 sf Storage= 26,680 cf

Plug-Flow detention time= 69.5 min calculated for 118,546 cf (100% of inflow)
 Center-of-Mass det. time= 67.4 min (833.1 - 765.7)

Volume	Invert	Avail.Storage	Storage Description
#1A	127.76'	12,437 cf	120.25'W x 117.54'L x 3.50'H Field A 49,468 cf Overall - 18,376 cf Embedded = 31,092 cf x 40.0% Voids
#2A	128.26'	18,376 cf	ADS_StormTech SC-740 +Cap x 400 Inside #1 Effective Size= 44.6"W x 30.0"H => 6.45 sf x 7.12'L = 45.9 cf Overall Size= 51.0"W x 30.0"H x 7.56'L with 0.44' Overlap 400 Chambers in 25 Rows
		30,813 cf	Total Available Storage

Storage Group A created with Chamber Wizard

Device	Routing	Invert	Outlet Devices
#1	Primary	127.66'	24.0" Round Culvert L= 92.0' CPP, projecting, no headwall, Ke= 0.900 Inlet / Outlet Invert= 127.66' / 127.15' S= 0.0055 '/' Cc= 0.900 n= 0.013 Corrugated PE, smooth interior, Flow Area= 3.14 sf
#2	Device 1	127.76'	4.0" Vert. Orifice/Grate C= 0.600 Limited to weir flow at low heads
#3	Device 1	128.39'	4.0' long x 0.5' breadth Broad-Crested Rectangular Weir Head (feet) 0.20 0.40 0.60 0.80 1.00 Coef. (English) 2.80 2.92 3.08 3.30 3.32

Primary OutFlow Max=16.40 cfs @ 12.25 hrs HW=130.55' TW=0.00' (Dynamic Tailwater)

- ↑ **1=Culvert** (Inlet Controls 16.40 cfs @ 5.22 fps)
- ↑ **2=Orifice/Grate** (Passes < 0.68 cfs potential flow)
- ↑ **3=Broad-Crested Rectangular Weir**(Passes < 42.02 cfs potential flow)

Pond 4P: Detention Chambers sC 740

Hydrograph

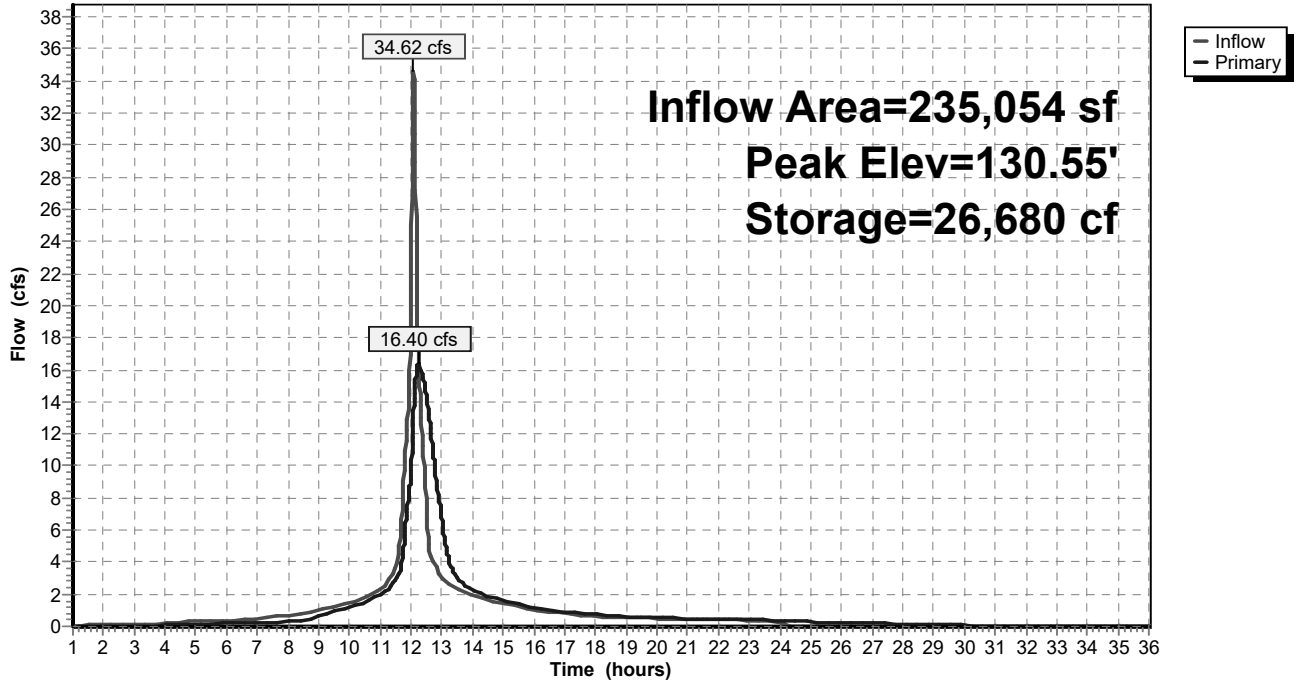

Summary for Link 1L: Leaching CB

Inflow Area = 9,774 sf, 0.00% Impervious, Inflow Depth = 0.23" for 50-year event
Inflow = 0.01 cfs @ 13.70 hrs, Volume= 187 cf
Primary = 0.01 cfs @ 13.70 hrs, Volume= 187 cf, Atten= 0%, Lag= 0.0 min

Primary outflow = Inflow, Time Span= 1.00-36.00 hrs, dt= 0.01 hrs

Link 1L: Leaching CB

Hydrograph

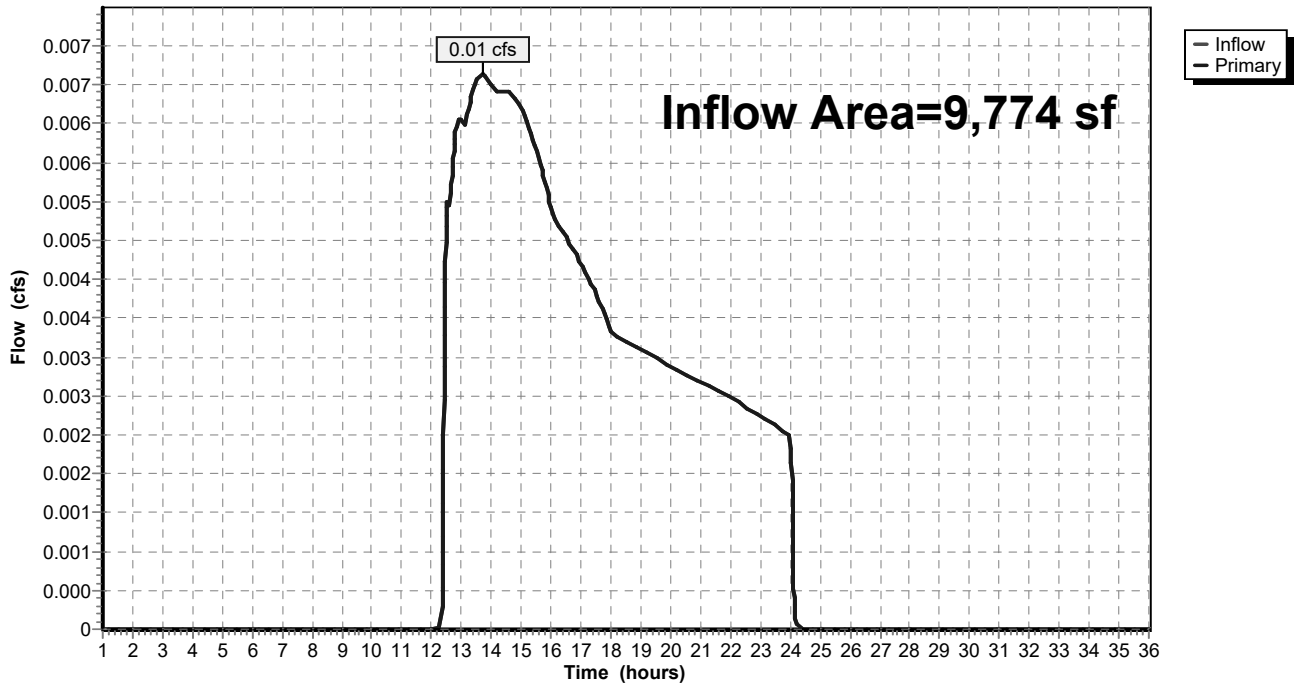

Summary for Link 2L: Isolated Wetlands

Inflow Area = 9,423 sf, 0.00% Impervious, Inflow Depth = 0.23" for 50-year event
Inflow = 0.01 cfs @ 13.70 hrs, Volume= 180 cf
Primary = 0.01 cfs @ 13.70 hrs, Volume= 180 cf, Atten= 0%, Lag= 0.0 min

Primary outflow = Inflow, Time Span= 1.00-36.00 hrs, dt= 0.01 hrs

Link 2L: Isolated Wetlands

Hydrograph

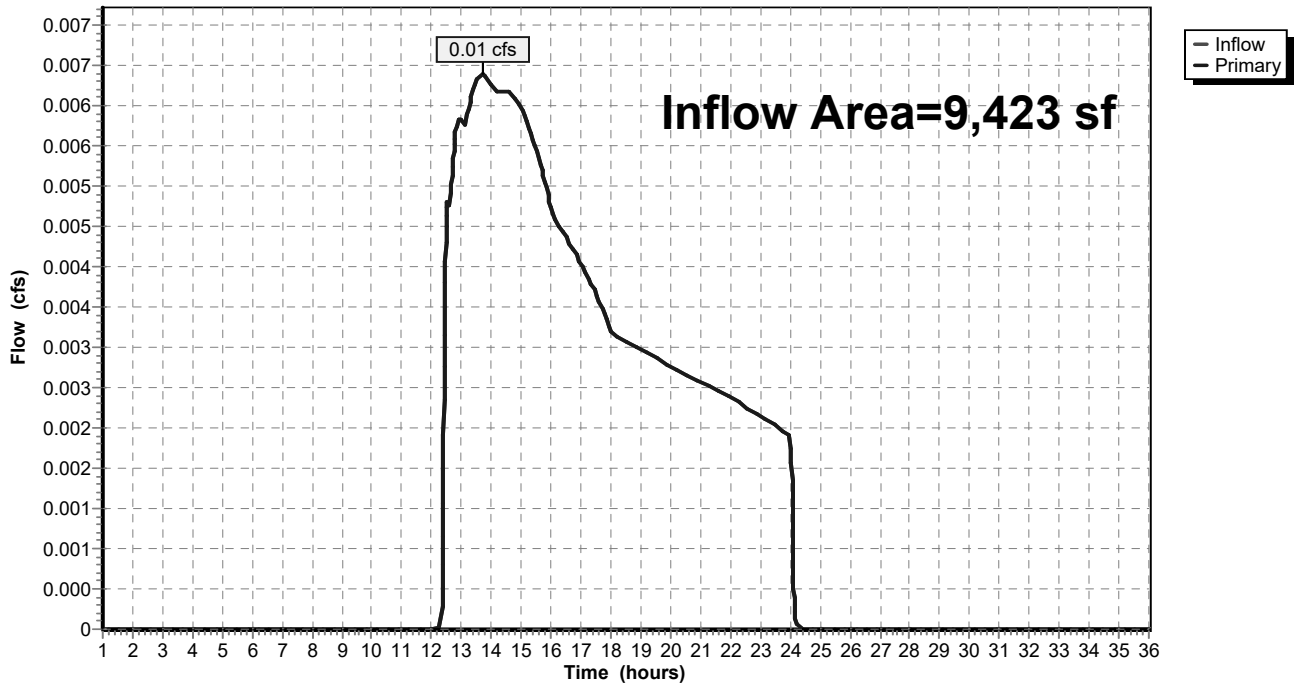

Spofford Post-Development

Prepared by Weston & Sampson

HydroCAD® 10.10-6a s/n 00455 © 2020 HydroCAD Software Solutions LLC

Type III 24-hr 50-year Rainfall=7.10"

Printed 11/5/2021

Page 121

Summary for Link 3L: Spofford Pond Wetlands

Inflow Area = 42,576 sf, 6.11% Impervious, Inflow Depth = 0.48" for 50-year event
Inflow = 0.20 cfs @ 12.14 hrs, Volume= 1,713 cf
Primary = 0.20 cfs @ 12.14 hrs, Volume= 1,713 cf, Atten= 0%, Lag= 0.0 min

Primary outflow = Inflow, Time Span= 1.00-36.00 hrs, dt= 0.01 hrs

Link 3L: Spofford Pond Wetlands

Hydrograph

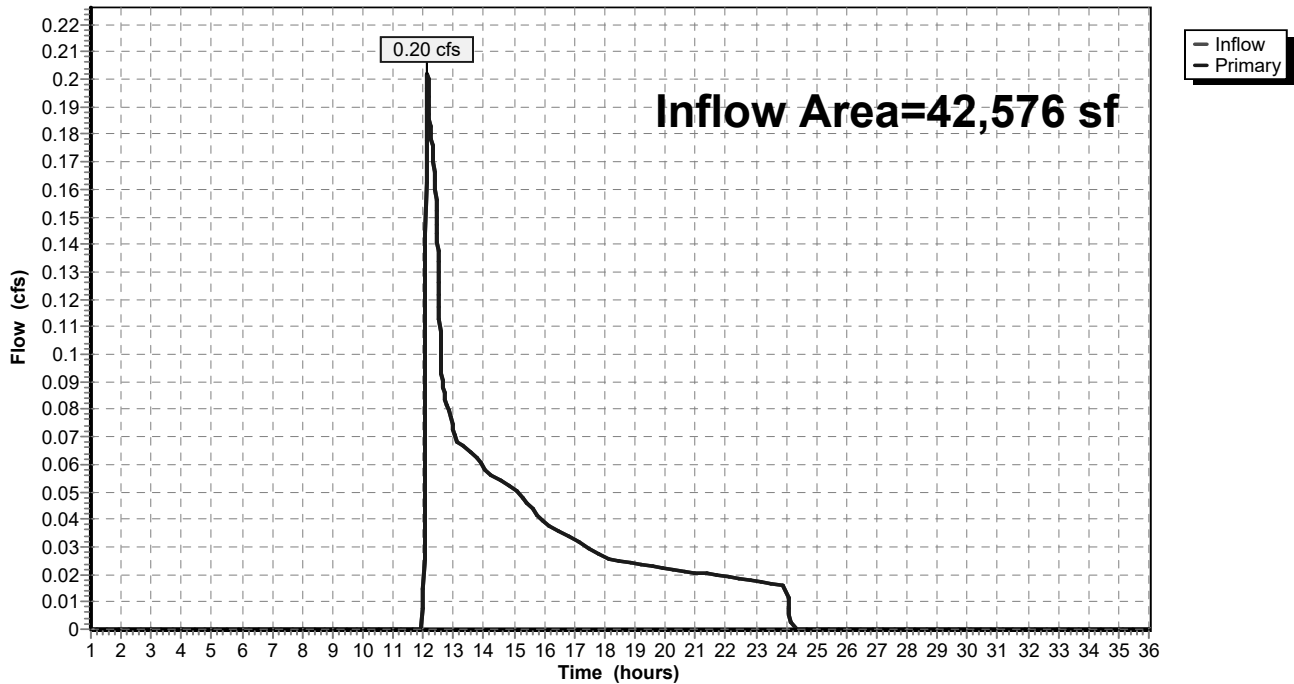

Summary for Link 4L: Vernal Pool Wetlands

Inflow Area = 245,744 sf, 86.33% Impervious, Inflow Depth > 5.81" for 50-year event
Inflow = 16.42 cfs @ 12.25 hrs, Volume= 118,899 cf
Primary = 16.42 cfs @ 12.25 hrs, Volume= 118,899 cf, Atten= 0%, Lag= 0.0 min
Routed to nonexistent node 25L

Primary outflow = Inflow, Time Span= 1.00-36.00 hrs, dt= 0.01 hrs

Link 4L: Vernal Pool Wetlands

Hydrograph

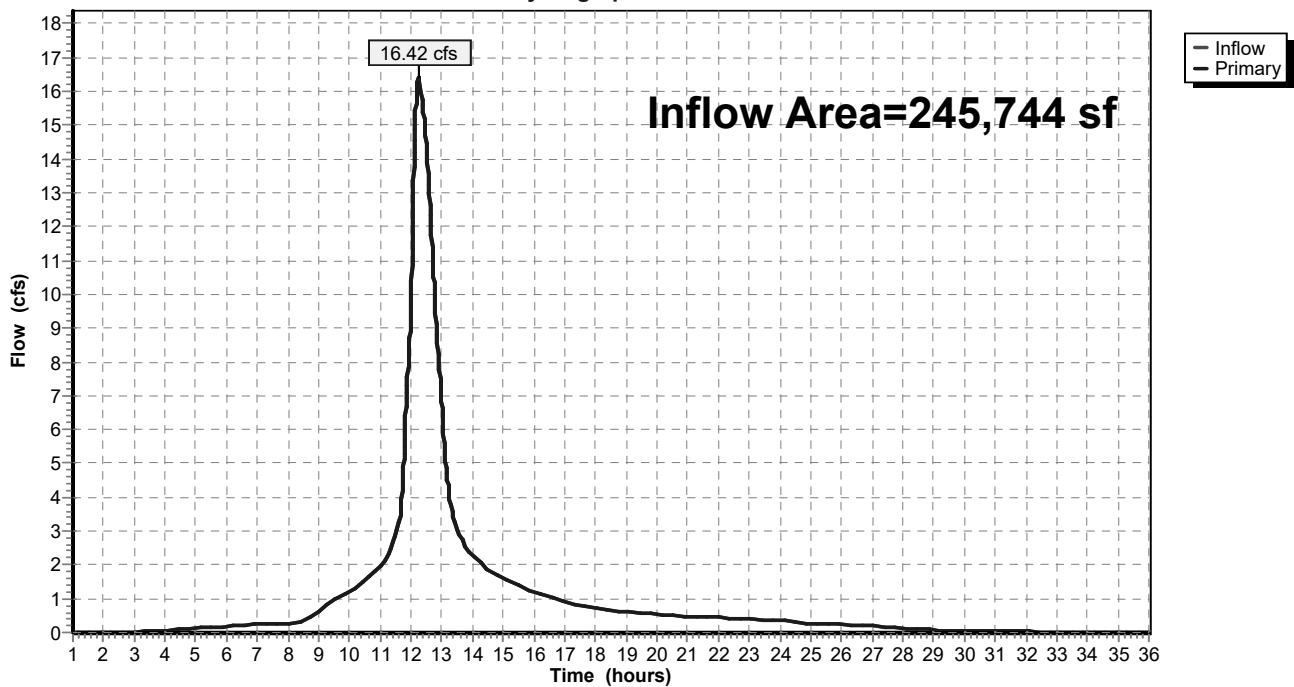

Spofford Post-Development

Prepared by Weston & Sampson

HydroCAD® 10.10-6a s/n 00455 © 2020 HydroCAD Software Solutions LLC

Type III 24-hr 100-year Rainfall=8.30"

Printed 11/5/2021

Page 123

Time span=1.00-36.00 hrs, dt=0.01 hrs, 3501 points
Runoff by SCS TR-20 method, UH=SCS, Weighted-CN
Reach routing by Dyn-Stor-Ind method - Pond routing by Dyn-Stor-Ind method

Subcatchment1S: Roof	Runoff Area=71,161 sf 100.00% Impervious Runoff Depth>8.06" Tc=6.0 min CN=98 Runoff=13.31 cfs 47,767 cf
Subcatchment2S: Sub 2	Runoff Area=9,774 sf 0.00% Impervious Runoff Depth=0.49" Tc=6.0 min CN=30 Runoff=0.04 cfs 399 cf
Subcatchment3S: Sub 3	Runoff Area=24,730 sf 73.09% Impervious Runoff Depth=5.91" Tc=6.0 min CN=80 Runoff=3.86 cfs 12,173 cf
Subcatchment4S: Sub 4	Runoff Area=13,951 sf 62.30% Impervious Runoff Depth=4.96" Tc=6.0 min CN=72 Runoff=1.86 cfs 5,765 cf
Subcatchment5S: Sub 5	Runoff Area=10,142 sf 79.94% Impervious Runoff Depth=6.38" Tc=6.0 min CN=84 Runoff=1.68 cfs 5,395 cf
Subcatchment6S: Sub 6	Runoff Area=18,754 sf 13.86% Impervious Runoff Depth=1.29" Tc=6.0 min CN=39 Runoff=0.45 cfs 2,008 cf
Subcatchment7S: Sub 7	Runoff Area=4,674 sf 100.00% Impervious Runoff Depth>8.06" Tc=6.0 min CN=98 Runoff=0.87 cfs 3,137 cf
Subcatchment8S: Sub 8	Runoff Area=23,822 sf 0.00% Impervious Runoff Depth=0.49" Tc=6.0 min CN=30 Runoff=0.09 cfs 972 cf
Subcatchment9S: Sub 9	Runoff Area=9,379 sf 95.68% Impervious Runoff Depth=7.70" Tc=6.0 min CN=95 Runoff=1.74 cfs 6,018 cf
Subcatchment10S: Sub 10	Runoff Area=18,532 sf 69.05% Impervious Runoff Depth=5.55" Tc=6.0 min CN=77 Runoff=2.74 cfs 8,571 cf
Subcatchment11S: Sub 11	Runoff Area=6,808 sf 98.43% Impervious Runoff Depth>7.94" Tc=6.0 min CN=97 Runoff=1.27 cfs 4,504 cf
Subcatchment12S: Sub 12	Runoff Area=5,470 sf 0.00% Impervious Runoff Depth=0.49" Tc=6.0 min CN=30 Runoff=0.02 cfs 223 cf
Subcatchment13S: Sub 13	Runoff Area=3,318 sf 87.70% Impervious Runoff Depth=7.10" Tc=6.0 min CN=90 Runoff=0.59 cfs 1,963 cf
Subcatchment14S: Sub 14	Runoff Area=3,898 sf 96.02% Impervious Runoff Depth=7.70" Tc=6.0 min CN=95 Runoff=0.72 cfs 2,501 cf
Subcatchment15S: Sub 15	Runoff Area=46,388 sf 96.62% Impervious Runoff Depth=7.82" Tc=6.0 min CN=96 Runoff=8.62 cfs 30,230 cf
Subcatchment16S: Sub 16	Runoff Area=11,222 sf 92.68% Impervious Runoff Depth=7.46" Tc=6.0 min CN=93 Runoff=2.05 cfs 6,977 cf

Spofford Post-Development

Prepared by Weston & Sampson

HydroCAD® 10.10-6a s/n 00455 © 2020 HydroCAD Software Solutions LLC

Type III 24-hr 100-year Rainfall=8.30"

Printed 11/5/2021

Page 124

Subcatchment 17S: Sub 17

Runoff Area=10,851 sf 98.57% Impervious Runoff Depth>7.94"
Tc=6.0 min CN=97 Runoff=2.02 cfs 7,179 cf

Subcatchment 18S: Sub 18

Runoff Area=10,690 sf 3.71% Impervious Runoff Depth=0.73"
Tc=6.0 min CN=33 Runoff=0.08 cfs 652 cf

Subcatchment 19S: Sub 19

Runoff Area=3,953 sf 0.00% Impervious Runoff Depth=0.49"
Tc=6.0 min CN=30 Runoff=0.01 cfs 161 cf

Pond 3P: Sediment Forebay

Peak Elev=134.01' Storage=979 cf Inflow=8.62 cfs 30,230 cf
Primary=8.33 cfs 29,828 cf Secondary=0.36 cfs 28 cf Outflow=8.69 cfs 29,856 cf

Pond 4P: Detention Chambers sC 740

Peak Elev=132.43' Storage=30,813 cf Inflow=41.40 cfs 141,809 cf
Outflow=23.19 cfs 141,436 cf

Link 1L: Leaching CB

Inflow=0.04 cfs 399 cf
Primary=0.04 cfs 399 cf

Link 2L: Isolated Wetlands

Inflow=0.03 cfs 384 cf
Primary=0.03 cfs 384 cf

Link 3L: Spofford Pond Wetlands

Inflow=0.45 cfs 2,980 cf
Primary=0.45 cfs 2,980 cf

Link 4L: Vernal Pool Wetlands

Inflow=23.27 cfs 142,089 cf
Primary=23.27 cfs 142,089 cf

Total Runoff Area = 307,517 sf Runoff Volume = 146,598 cf Average Runoff Depth = 5.72"
30.17% Pervious = 92,770 sf 69.83% Impervious = 214,747 sf

Spofford Post-Development

Prepared by Weston & Sampson

HydroCAD® 10.10-6a s/n 00455 © 2020 HydroCAD Software Solutions LLC

Type III 24-hr 100-year Rainfall=8.30"

Printed 11/5/2021

Page 125

Summary for Subcatchment 1S: Roof

Runoff = 13.31 cfs @ 12.08 hrs, Volume= 47,767 cf, Depth> 8.06"
Routed to Pond 4P : Detention Chambers sC 740

Runoff by SCS TR-20 method, UH=SCS, Weighted-CN, Time Span= 1.00-36.00 hrs, dt= 0.01 hrs
Type III 24-hr 100-year Rainfall=8.30"

Area (sf)	CN	Description
71,161	98	Roofs, HSG A
71,161		100.00% Impervious Area

Tc (min)	Length (feet)	Slope (ft/ft)	Velocity (ft/sec)	Capacity (cfs)	Description
6.0					Direct Entry,

Subcatchment 1S: Roof

Hydrograph

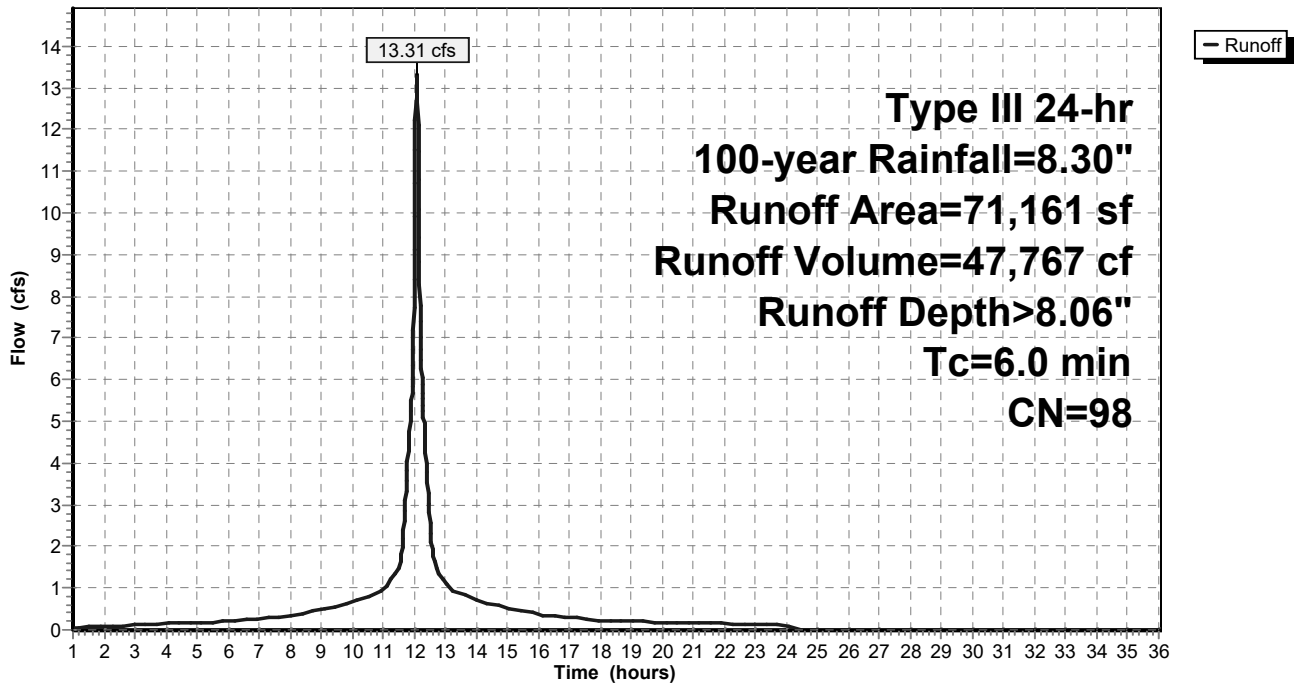

Spofford Post-Development

Prepared by Weston & Sampson

HydroCAD® 10.10-6a s/n 00455 © 2020 HydroCAD Software Solutions LLC

Type III 24-hr 100-year Rainfall=8.30"

Printed 11/5/2021

Page 126

Summary for Subcatchment 2S: Sub 2

Runoff = 0.04 cfs @ 12.39 hrs, Volume= 399 cf, Depth= 0.49"

Routed to Link 1L : Leaching CB

Runoff by SCS TR-20 method, UH=SCS, Weighted-CN, Time Span= 1.00-36.00 hrs, dt= 0.01 hrs
Type III 24-hr 100-year Rainfall=8.30"

Area (sf)	CN	Description
* 9,774	30	Grass
9,774		100.00% Pervious Area

Tc (min)	Length (feet)	Slope (ft/ft)	Velocity (ft/sec)	Capacity (cfs)	Description
6.0					Direct Entry,

Subcatchment 2S: Sub 2

Hydrograph

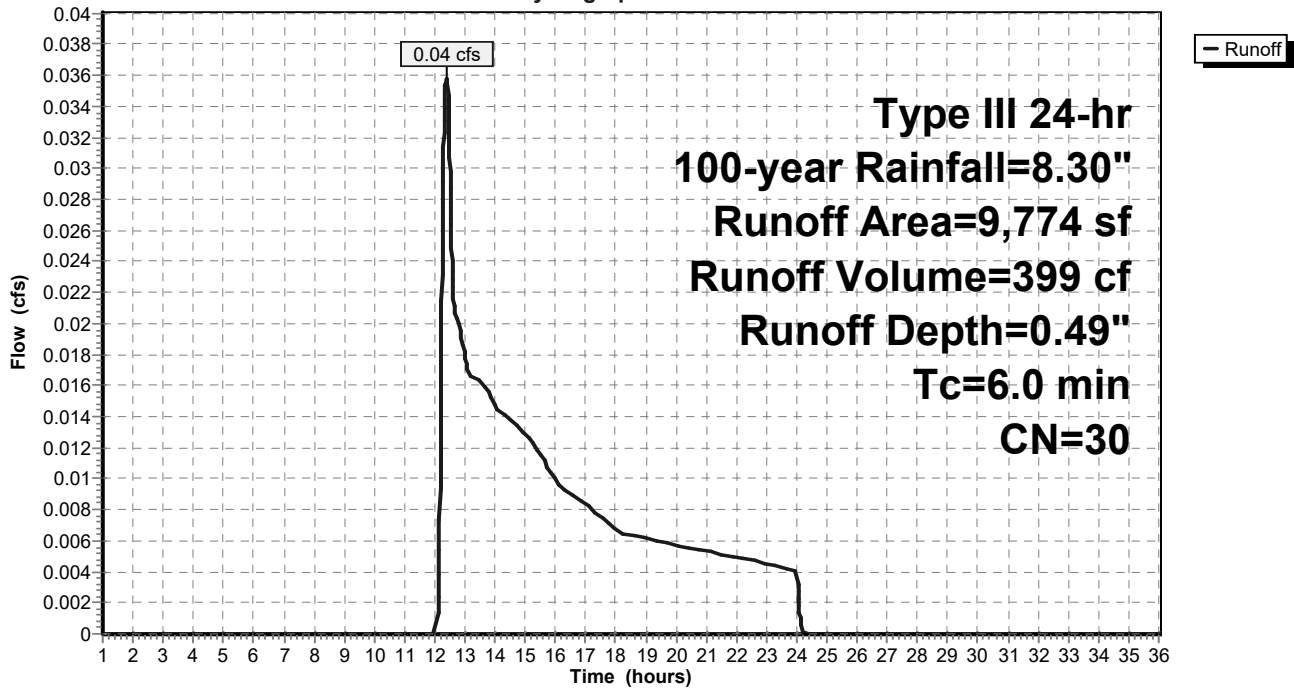

Spofford Post-Development

Prepared by Weston & Sampson

HydroCAD® 10.10-6a s/n 00455 © 2020 HydroCAD Software Solutions LLC

Type III 24-hr 100-year Rainfall=8.30"

Printed 11/5/2021

Page 127

Summary for Subcatchment 3S: Sub 3

Runoff = 3.86 cfs @ 12.09 hrs, Volume= 12,173 cf, Depth= 5.91"
 Routed to Pond 4P : Detention Chambers sC 740

Runoff by SCS TR-20 method, UH=SCS, Weighted-CN, Time Span= 1.00-36.00 hrs, dt= 0.01 hrs
 Type III 24-hr 100-year Rainfall=8.30"

Area (sf)	CN	Description
8,972	98	Paved parking, HSG A
* 9,104	98	Turf (impervious)
* 5,760	30	Grass
894	30	Woods, Good, HSG A
24,730	80	Weighted Average
6,654		26.91% Pervious Area
18,076		73.09% Impervious Area

Tc (min)	Length (feet)	Slope (ft/ft)	Velocity (ft/sec)	Capacity (cfs)	Description
6.0					Direct Entry,

Subcatchment 3S: Sub 3

Hydrograph

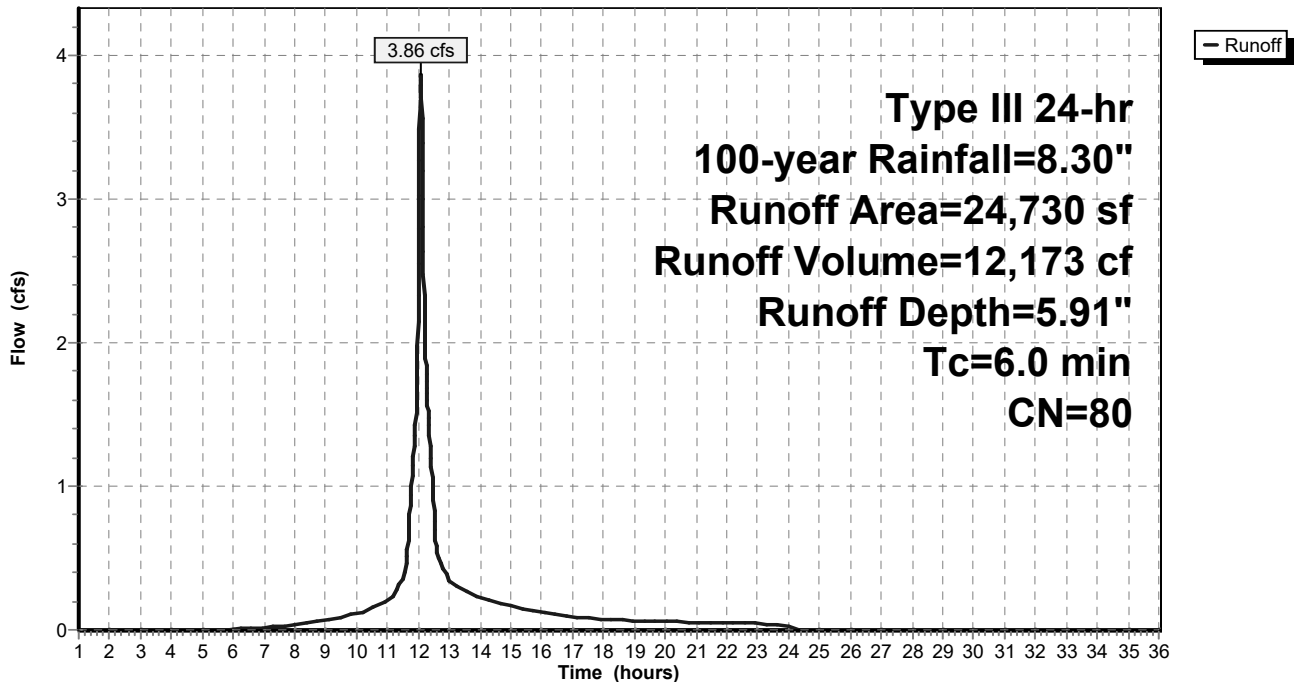

Spofford Post-Development

Prepared by Weston & Sampson

HydroCAD® 10.10-6a s/n 00455 © 2020 HydroCAD Software Solutions LLC

Type III 24-hr 100-year Rainfall=8.30"

Printed 11/5/2021

Page 128

Summary for Subcatchment 4S: Sub 4

Runoff = 1.86 cfs @ 12.09 hrs, Volume= 5,765 cf, Depth= 4.96"
Routed to Pond 4P : Detention Chambers sC 740

Runoff by SCS TR-20 method, UH=SCS, Weighted-CN, Time Span= 1.00-36.00 hrs, dt= 0.01 hrs
Type III 24-hr 100-year Rainfall=8.30"

Area (sf)	CN	Description
8,691	98	Paved parking, HSG A
2,060	30	Woods, Good, HSG A
* 3,200	30	Grass
13,951	72	Weighted Average
5,260		37.70% Pervious Area
8,691		62.30% Impervious Area

Tc (min)	Length (feet)	Slope (ft/ft)	Velocity (ft/sec)	Capacity (cfs)	Description
6.0					Direct Entry,

Subcatchment 4S: Sub 4

Hydrograph

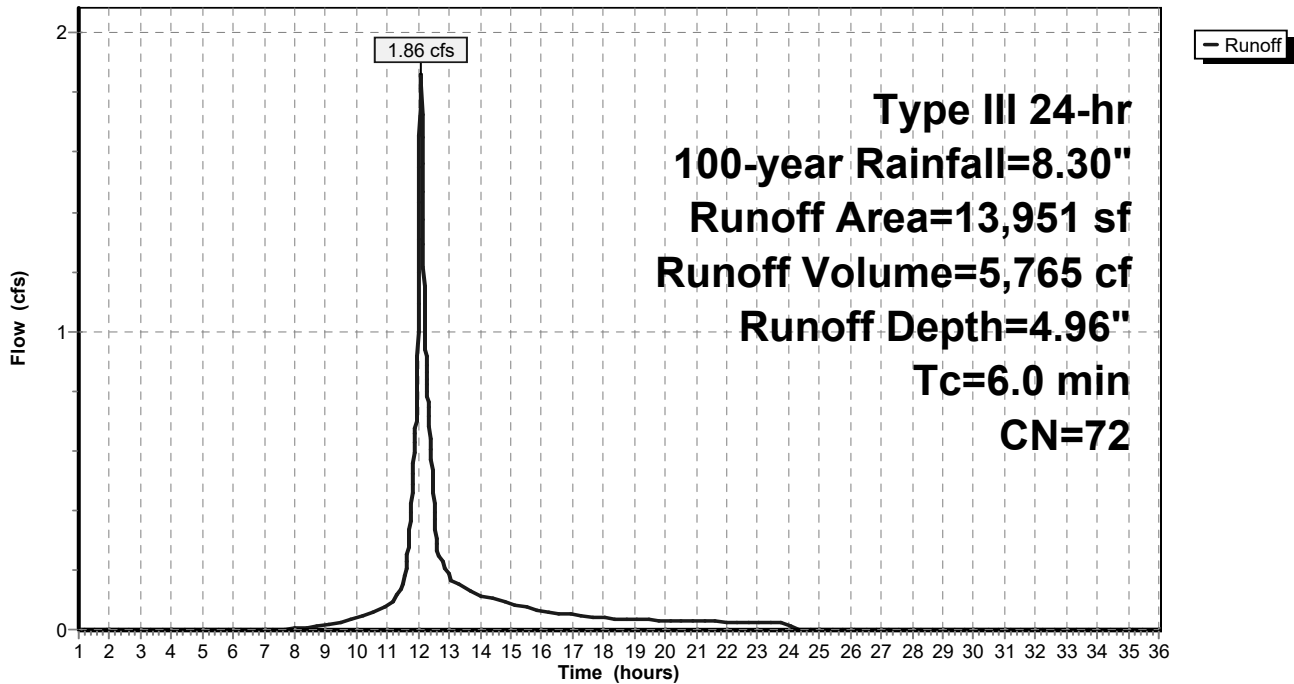

Spofford Post-Development

Prepared by Weston & Sampson

HydroCAD® 10.10-6a s/n 00455 © 2020 HydroCAD Software Solutions LLC

Type III 24-hr 100-year Rainfall=8.30"

Printed 11/5/2021

Page 129

Summary for Subcatchment 5S: Sub 5

Runoff = 1.68 cfs @ 12.09 hrs, Volume= 5,395 cf, Depth= 6.38"
Routed to Pond 4P : Detention Chambers sC 740

Runoff by SCS TR-20 method, UH=SCS, Weighted-CN, Time Span= 1.00-36.00 hrs, dt= 0.01 hrs
Type III 24-hr 100-year Rainfall=8.30"

Area (sf)	CN	Description
8,108	98	Paved parking, HSG A
* 2,034	30	Grass
10,142	84	Weighted Average
2,034		20.06% Pervious Area
8,108		79.94% Impervious Area

Tc (min)	Length (feet)	Slope (ft/ft)	Velocity (ft/sec)	Capacity (cfs)	Description
6.0					Direct Entry,

Subcatchment 5S: Sub 5

Hydrograph

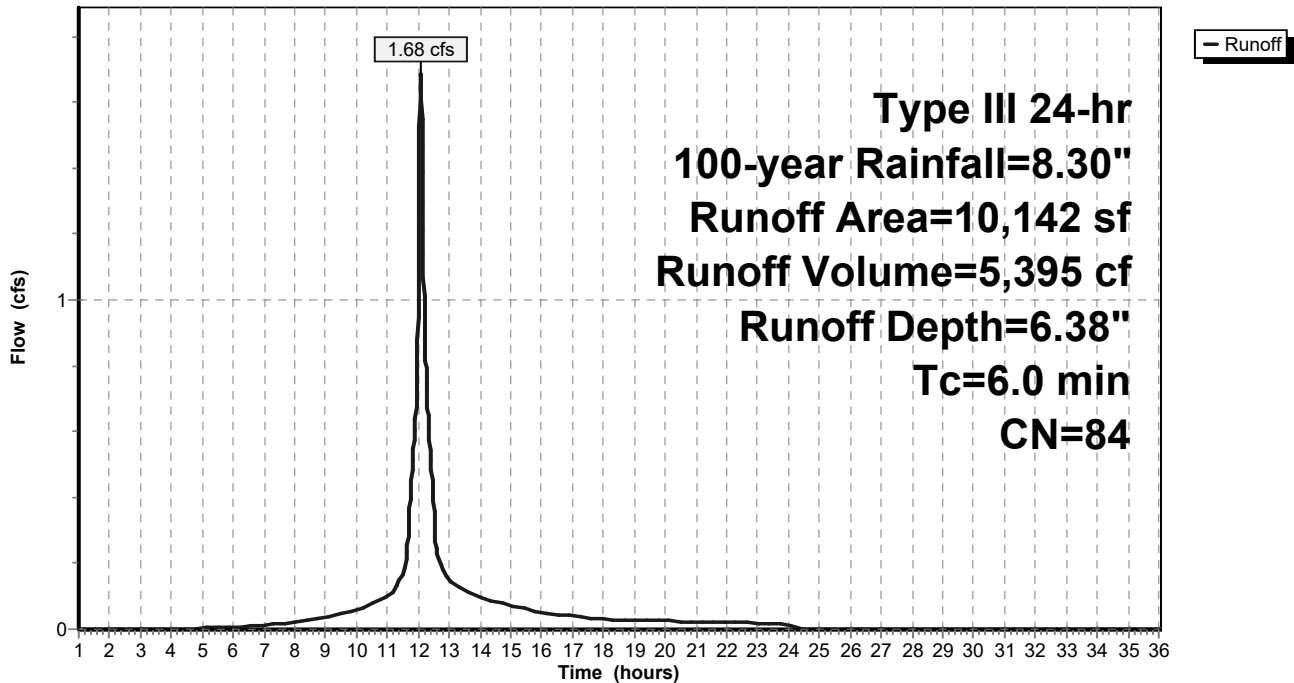

Spofford Post-Development

Prepared by Weston & Sampson

HydroCAD® 10.10-6a s/n 00455 © 2020 HydroCAD Software Solutions LLC

Type III 24-hr 100-year Rainfall=8.30"

Printed 11/5/2021

Page 130

Summary for Subcatchment 6S: Sub 6

Runoff = 0.45 cfs @ 12.12 hrs, Volume= 2,008 cf, Depth= 1.29"

Routed to Link 3L : Spofford Pond Wetlands

Runoff by SCS TR-20 method, UH=SCS, Weighted-CN, Time Span= 1.00-36.00 hrs, dt= 0.01 hrs
 Type III 24-hr 100-year Rainfall=8.30"

	Area (sf)	CN	Description
*	8,202	30	Grass
	7,952	30	Woods, Good, HSG A
	2,600	98	Paved parking, HSG A
	18,754	39	Weighted Average
	16,154		86.14% Pervious Area
	2,600		13.86% Impervious Area

Tc (min)	Length (feet)	Slope (ft/ft)	Velocity (ft/sec)	Capacity (cfs)	Description
6.0					Direct Entry,

Subcatchment 6S: Sub 6

Hydrograph

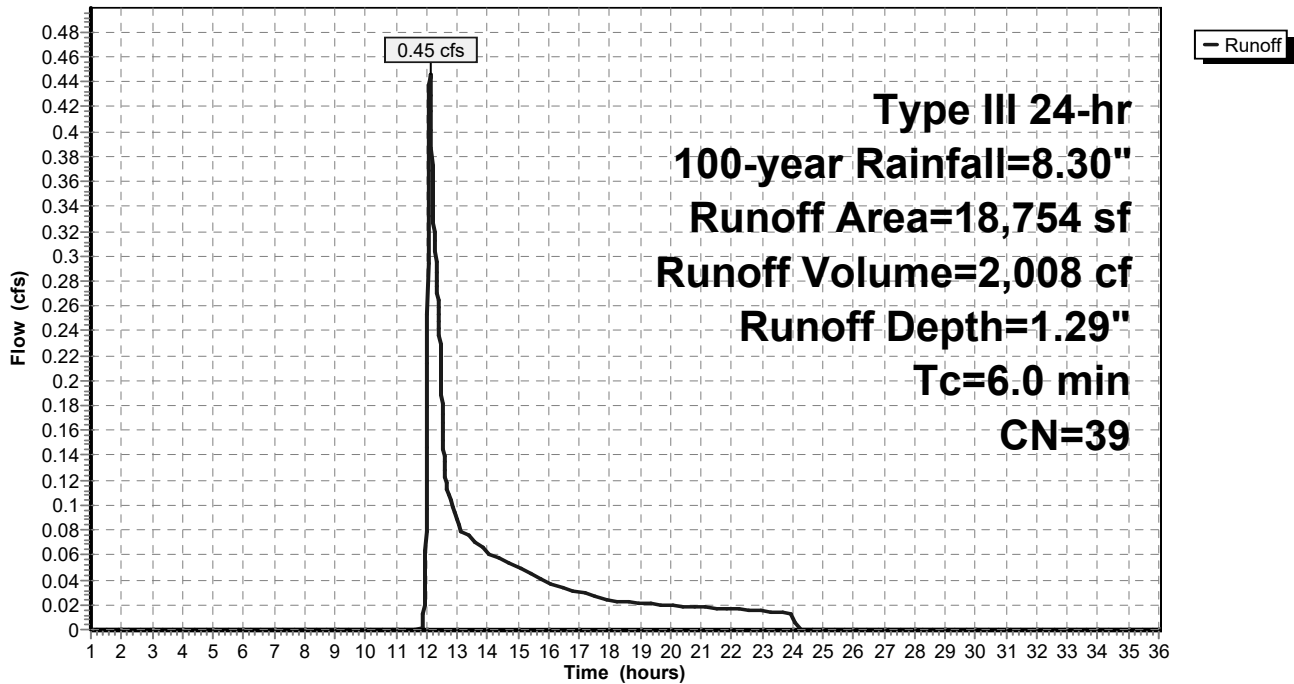

Spofford Post-Development

Prepared by Weston & Sampson

HydroCAD® 10.10-6a s/n 00455 © 2020 HydroCAD Software Solutions LLC

Type III 24-hr 100-year Rainfall=8.30"

Printed 11/5/2021

Page 131

Summary for Subcatchment 7S: Sub 7

Runoff = 0.87 cfs @ 12.08 hrs, Volume= 3,137 cf, Depth> 8.06"
Routed to Pond 4P : Detention Chambers sC 740

Runoff by SCS TR-20 method, UH=SCS, Weighted-CN, Time Span= 1.00-36.00 hrs, dt= 0.01 hrs
Type III 24-hr 100-year Rainfall=8.30"

Area (sf)	CN	Description
4,674	98	Paved parking, HSG A
4,674		100.00% Impervious Area

Tc (min)	Length (feet)	Slope (ft/ft)	Velocity (ft/sec)	Capacity (cfs)	Description
6.0					Direct Entry,

Subcatchment 7S: Sub 7

Hydrograph

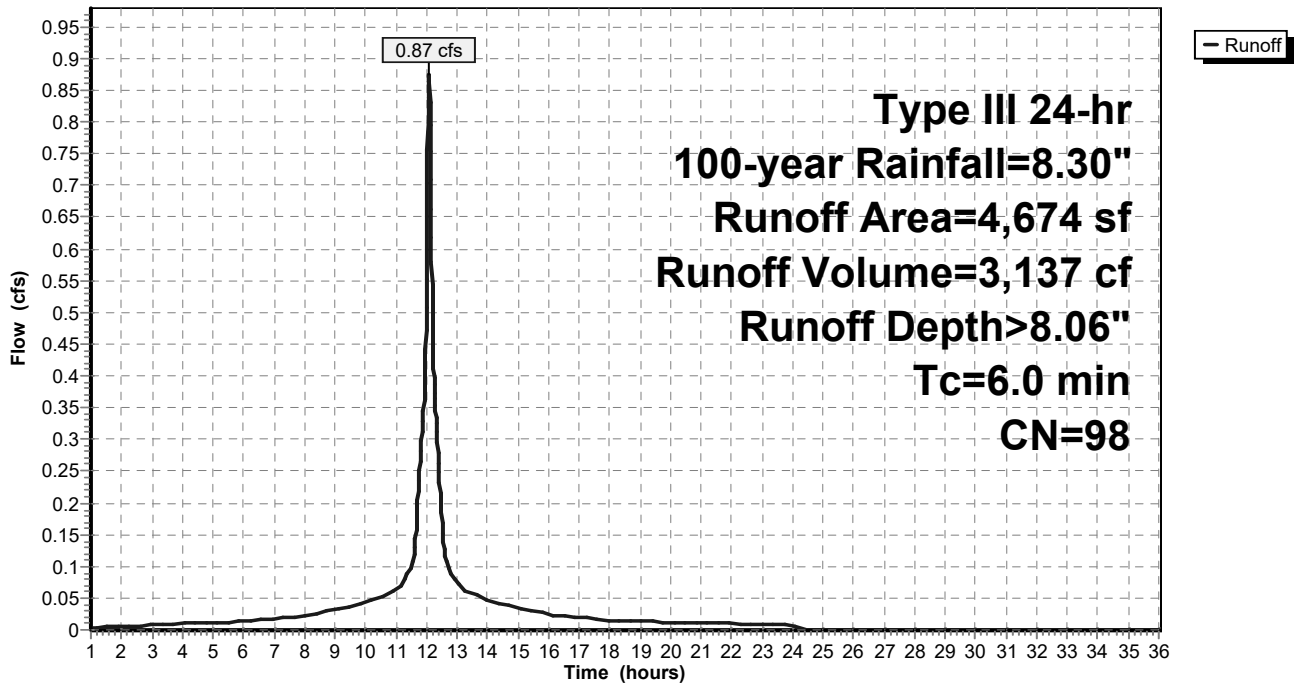

Spofford Post-Development

Prepared by Weston & Sampson

HydroCAD® 10.10-6a s/n 00455 © 2020 HydroCAD Software Solutions LLC

Type III 24-hr 100-year Rainfall=8.30"

Printed 11/5/2021

Page 132

Summary for Subcatchment 8S: Sub 8

Runoff = 0.09 cfs @ 12.39 hrs, Volume= 972 cf, Depth= 0.49"

Routed to Link 3L : Spofford Pond Wetlands

Runoff by SCS TR-20 method, UH=SCS, Weighted-CN, Time Span= 1.00-36.00 hrs, dt= 0.01 hrs
 Type III 24-hr 100-year Rainfall=8.30"

Area (sf)	CN	Description
* 23,822	30	Grass
23,822		100.00% Pervious Area

Tc (min)	Length (feet)	Slope (ft/ft)	Velocity (ft/sec)	Capacity (cfs)	Description
6.0					Direct Entry,

Subcatchment 8S: Sub 8

Hydrograph

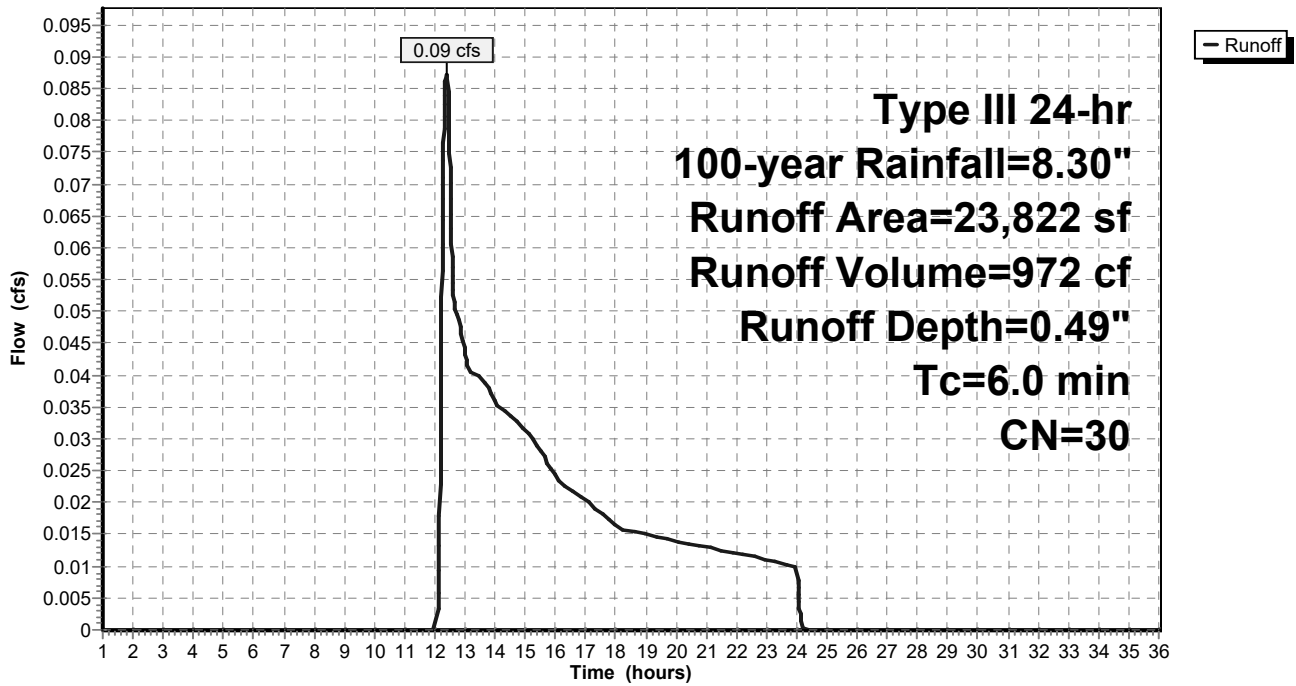

Spofford Post-Development

Prepared by Weston & Sampson

HydroCAD® 10.10-6a s/n 00455 © 2020 HydroCAD Software Solutions LLC

Type III 24-hr 100-year Rainfall=8.30"

Printed 11/5/2021

Page 133

Summary for Subcatchment 9S: Sub 9

Runoff = 1.74 cfs @ 12.08 hrs, Volume= 6,018 cf, Depth= 7.70"
Routed to Pond 4P : Detention Chambers sC 740

Runoff by SCS TR-20 method, UH=SCS, Weighted-CN, Time Span= 1.00-36.00 hrs, dt= 0.01 hrs
Type III 24-hr 100-year Rainfall=8.30"

Area (sf)	CN	Description
8,974	98	Paved parking, HSG A
* 405	30	Grass
9,379	95	Weighted Average
405		4.32% Pervious Area
8,974		95.68% Impervious Area

Tc (min)	Length (feet)	Slope (ft/ft)	Velocity (ft/sec)	Capacity (cfs)	Description
6.0					Direct Entry,

Subcatchment 9S: Sub 9

Hydrograph

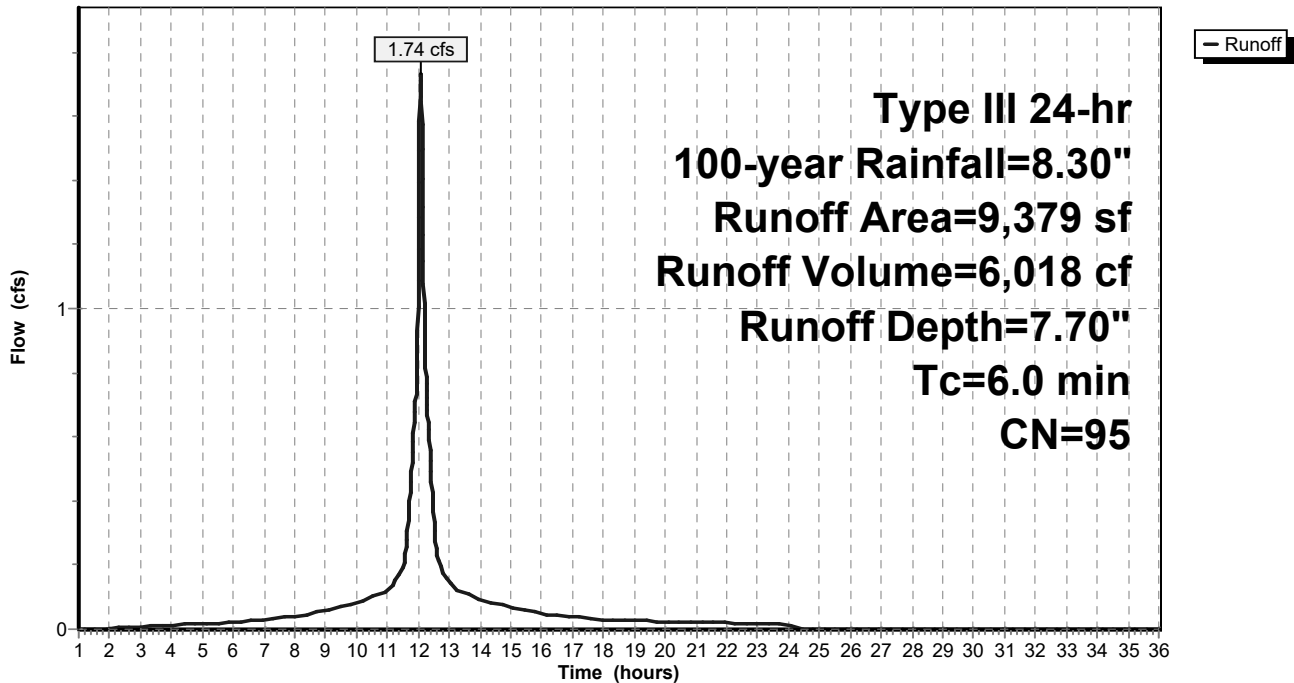

Spofford Post-Development

Prepared by Weston & Sampson

HydroCAD® 10.10-6a s/n 00455 © 2020 HydroCAD Software Solutions LLC

Type III 24-hr 100-year Rainfall=8.30"

Printed 11/5/2021

Page 134

Summary for Subcatchment 10S: Sub 10

Runoff = 2.74 cfs @ 12.09 hrs, Volume= 8,571 cf, Depth= 5.55"
Routed to Pond 4P : Detention Chambers sC 740

Runoff by SCS TR-20 method, UH=SCS, Weighted-CN, Time Span= 1.00-36.00 hrs, dt= 0.01 hrs
Type III 24-hr 100-year Rainfall=8.30"

Area (sf)	CN	Description
12,796	98	Paved parking, HSG A
424	30	Woods, Good, HSG A
* 5,312	30	Grass
18,532	77	Weighted Average
5,736		30.95% Pervious Area
12,796		69.05% Impervious Area

Tc (min)	Length (feet)	Slope (ft/ft)	Velocity (ft/sec)	Capacity (cfs)	Description
6.0					Direct Entry,

Subcatchment 10S: Sub 10

Hydrograph

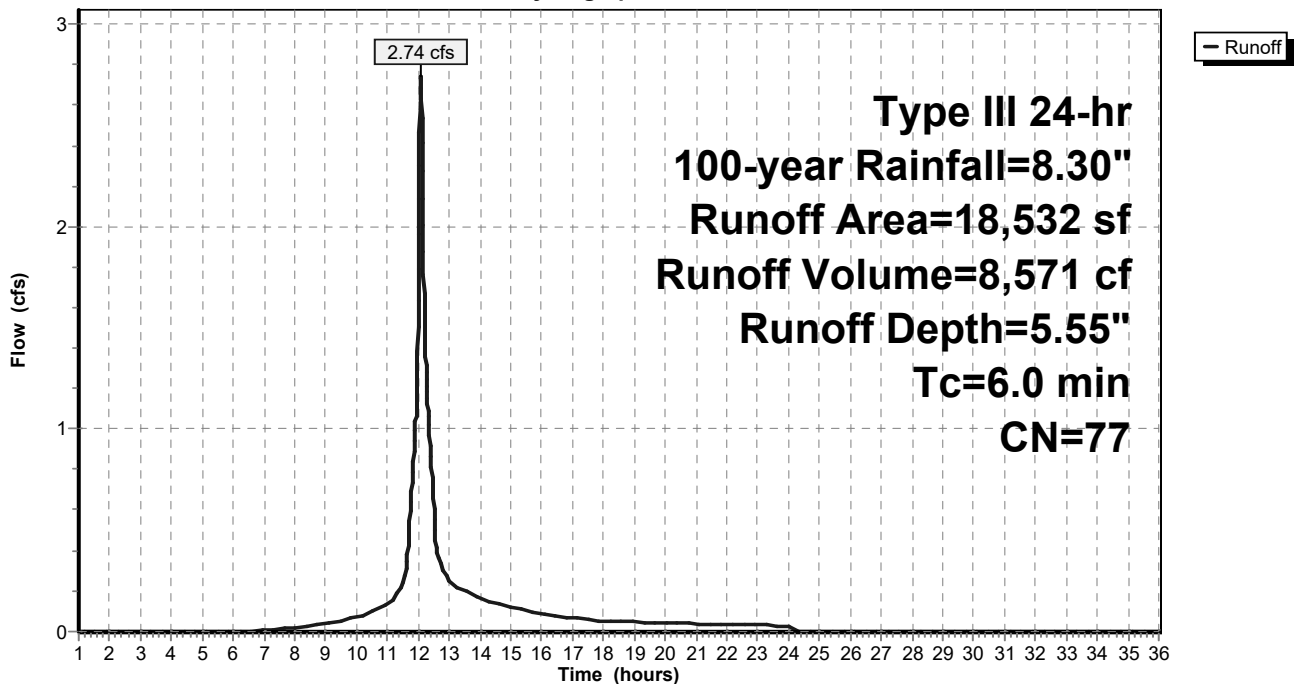

Spofford Post-Development

Prepared by Weston & Sampson

HydroCAD® 10.10-6a s/n 00455 © 2020 HydroCAD Software Solutions LLC

Type III 24-hr 100-year Rainfall=8.30"

Printed 11/5/2021

Page 135

Summary for Subcatchment 11S: Sub 11

Runoff = 1.27 cfs @ 12.08 hrs, Volume= 4,504 cf, Depth> 7.94"
Routed to Pond 4P : Detention Chambers sC 740

Runoff by SCS TR-20 method, UH=SCS, Weighted-CN, Time Span= 1.00-36.00 hrs, dt= 0.01 hrs
Type III 24-hr 100-year Rainfall=8.30"

Area (sf)	CN	Description
6,701	98	Paved parking, HSG A
* 107	30	Grass
6,808	97	Weighted Average
107		1.57% Pervious Area
6,701		98.43% Impervious Area

Tc (min)	Length (feet)	Slope (ft/ft)	Velocity (ft/sec)	Capacity (cfs)	Description
6.0					Direct Entry,

Subcatchment 11S: Sub 11

Hydrograph

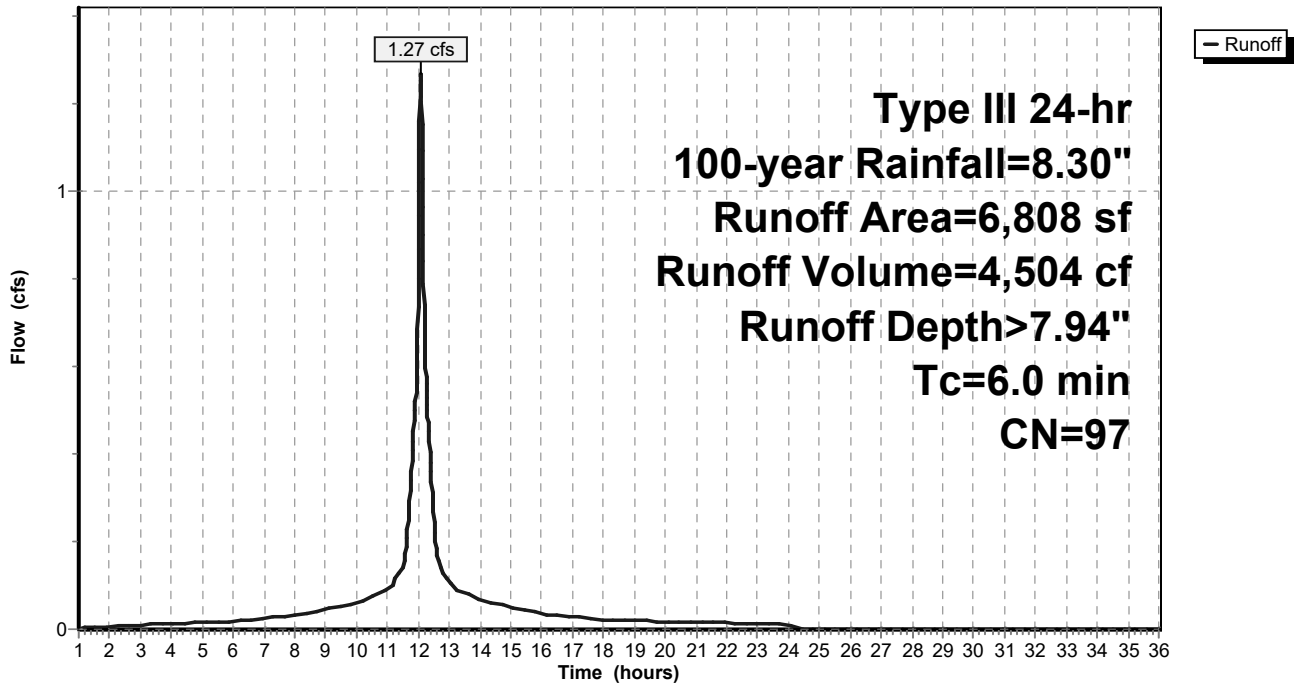

Spofford Post-Development

Prepared by Weston & Sampson

HydroCAD® 10.10-6a s/n 00455 © 2020 HydroCAD Software Solutions LLC

Type III 24-hr 100-year Rainfall=8.30"

Printed 11/5/2021

Page 136

Summary for Subcatchment 12S: Sub 12

Runoff = 0.02 cfs @ 12.39 hrs, Volume= 223 cf, Depth= 0.49"
 Routed to Link 2L : Isolated Wetlands

Runoff by SCS TR-20 method, UH=SCS, Weighted-CN, Time Span= 1.00-36.00 hrs, dt= 0.01 hrs
 Type III 24-hr 100-year Rainfall=8.30"

Area (sf)	CN	Description
* 5,470	30	Grass
5,470		100.00% Pervious Area

Tc (min)	Length (feet)	Slope (ft/ft)	Velocity (ft/sec)	Capacity (cfs)	Description
6.0					Direct Entry,

Subcatchment 12S: Sub 12

Hydrograph

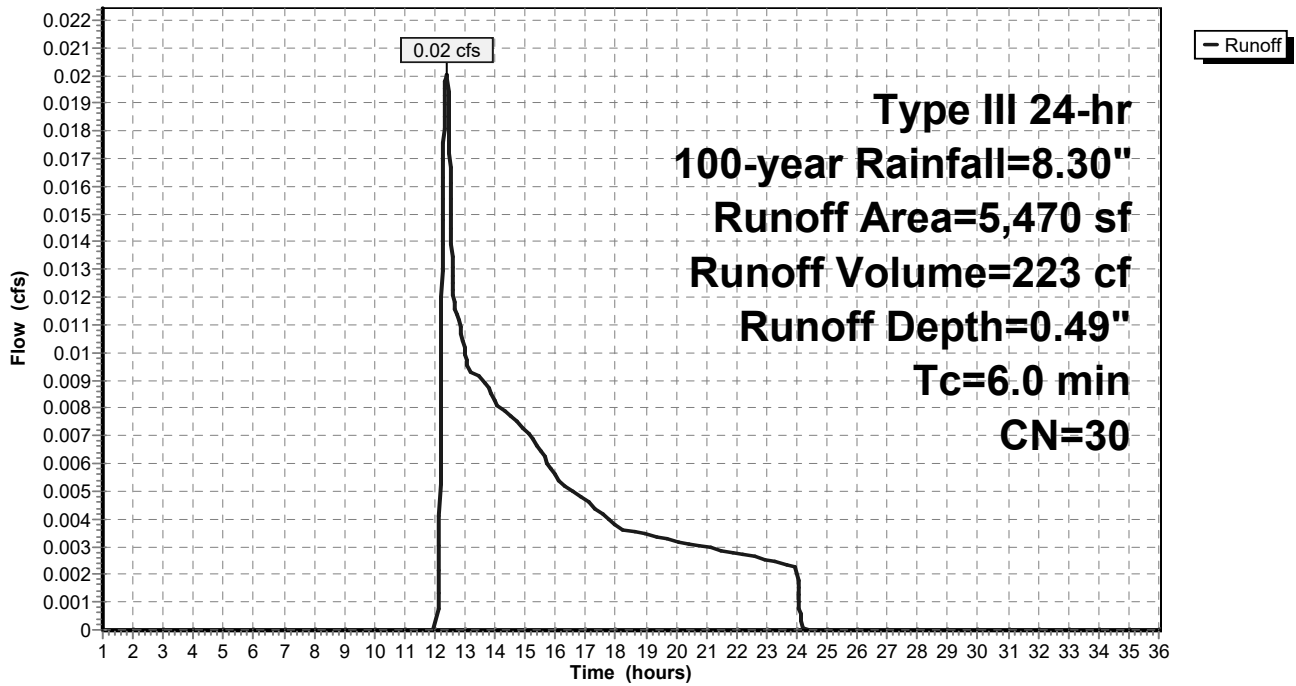

Spofford Post-Development

Prepared by Weston & Sampson

HydroCAD® 10.10-6a s/n 00455 © 2020 HydroCAD Software Solutions LLC

Type III 24-hr 100-year Rainfall=8.30"

Printed 11/5/2021

Page 137

Summary for Subcatchment 13S: Sub 13

Runoff = 0.59 cfs @ 12.08 hrs, Volume= 1,963 cf, Depth= 7.10"
Routed to Pond 4P : Detention Chambers sC 740

Runoff by SCS TR-20 method, UH=SCS, Weighted-CN, Time Span= 1.00-36.00 hrs, dt= 0.01 hrs
Type III 24-hr 100-year Rainfall=8.30"

Area (sf)	CN	Description
2,910	98	Paved parking, HSG A
* 408	30	Grass
3,318	90	Weighted Average
408		12.30% Pervious Area
2,910		87.70% Impervious Area

Tc (min)	Length (feet)	Slope (ft/ft)	Velocity (ft/sec)	Capacity (cfs)	Description
6.0					Direct Entry,

Subcatchment 13S: Sub 13

Hydrograph

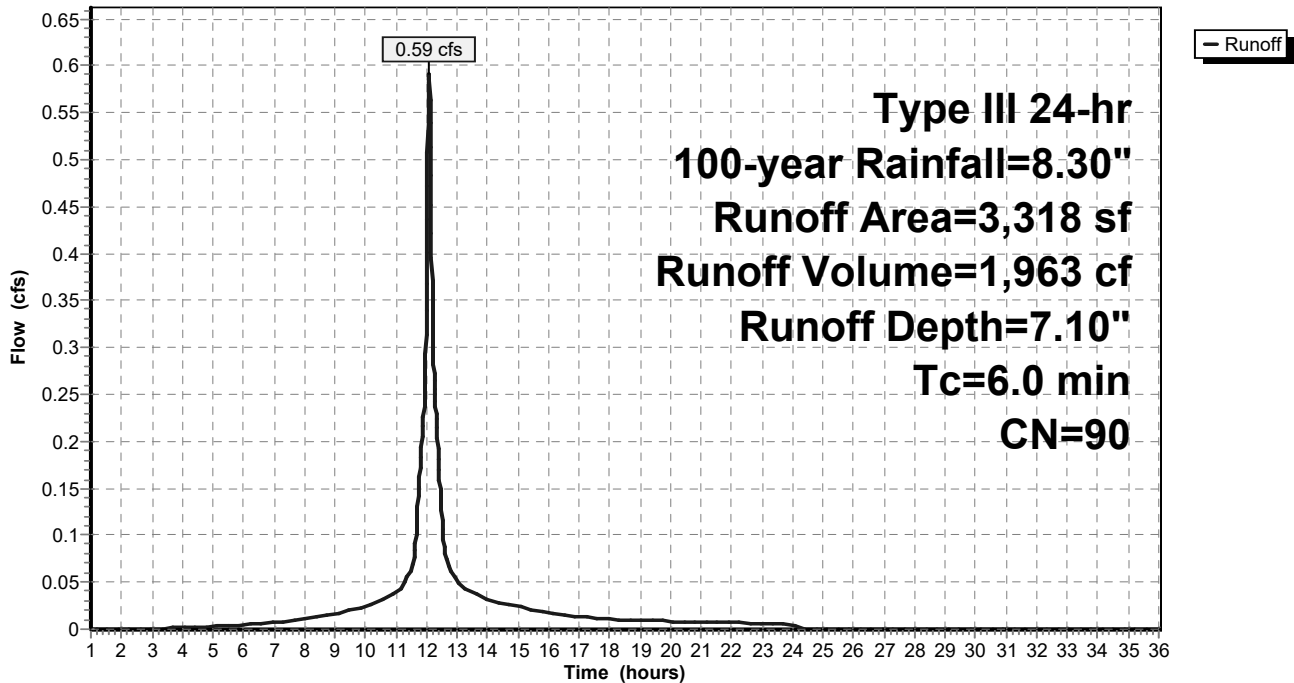

Spofford Post-Development

Prepared by Weston & Sampson

HydroCAD® 10.10-6a s/n 00455 © 2020 HydroCAD Software Solutions LLC

Type III 24-hr 100-year Rainfall=8.30"

Printed 11/5/2021

Page 138

Summary for Subcatchment 14S: Sub 14

Runoff = 0.72 cfs @ 12.08 hrs, Volume= 2,501 cf, Depth= 7.70"
 Routed to Pond 4P : Detention Chambers sC 740

Runoff by SCS TR-20 method, UH=SCS, Weighted-CN, Time Span= 1.00-36.00 hrs, dt= 0.01 hrs
 Type III 24-hr 100-year Rainfall=8.30"

Area (sf)	CN	Description
3,743	98	Paved parking, HSG A
* 155	30	Grass
3,898	95	Weighted Average
155		3.98% Pervious Area
3,743		96.02% Impervious Area

Tc (min)	Length (feet)	Slope (ft/ft)	Velocity (ft/sec)	Capacity (cfs)	Description
6.0					Direct Entry,

Subcatchment 14S: Sub 14

Hydrograph

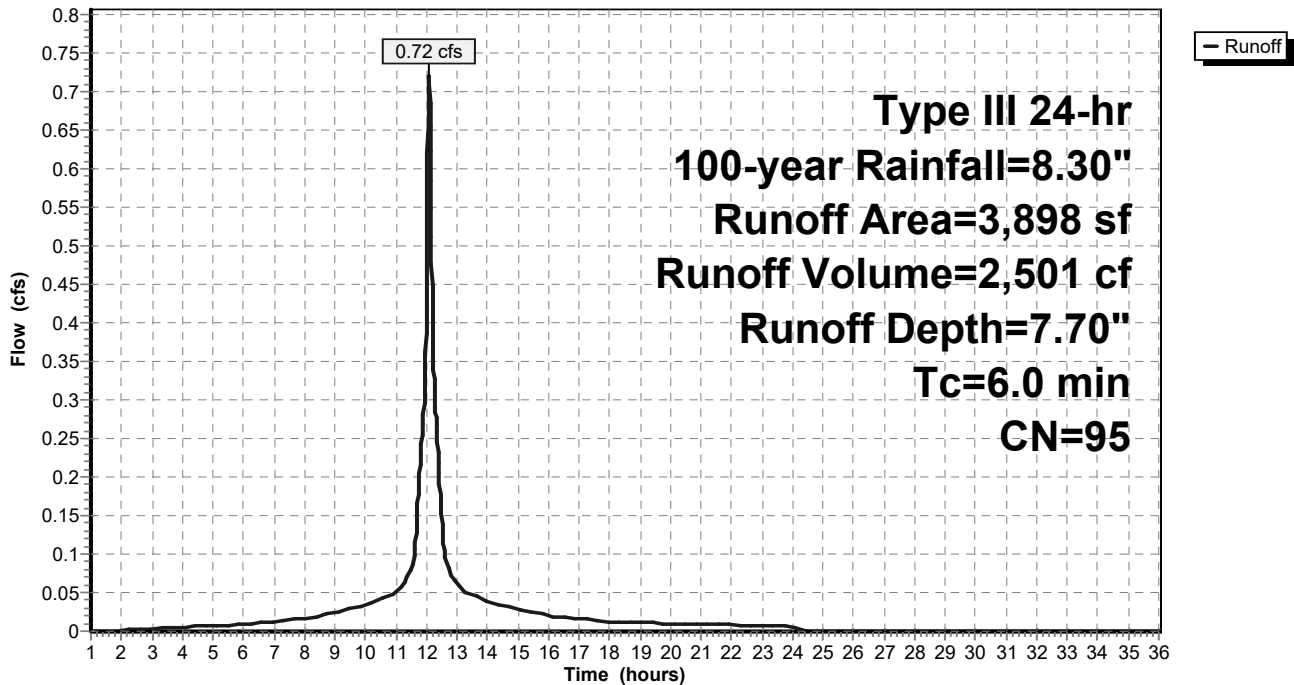

Spofford Post-Development

Prepared by Weston & Sampson

HydroCAD® 10.10-6a s/n 00455 © 2020 HydroCAD Software Solutions LLC

Type III 24-hr 100-year Rainfall=8.30"

Printed 11/5/2021

Page 139

Summary for Subcatchment 15S: Sub 15

Runoff = 8.62 cfs @ 12.08 hrs, Volume= 30,230 cf, Depth= 7.82"

Routed to Pond 3P : Sediment Forebay

Runoff by SCS TR-20 method, UH=SCS, Weighted-CN, Time Span= 1.00-36.00 hrs, dt= 0.01 hrs
 Type III 24-hr 100-year Rainfall=8.30"

	Area (sf)	CN	Description
*	1,568	30	Grass
	44,820	98	Paved parking, HSG A
	46,388	96	Weighted Average
	1,568		3.38% Pervious Area
	44,820		96.62% Impervious Area

Tc (min)	Length (feet)	Slope (ft/ft)	Velocity (ft/sec)	Capacity (cfs)	Description
6.0					Direct Entry,

Subcatchment 15S: Sub 15

Hydrograph

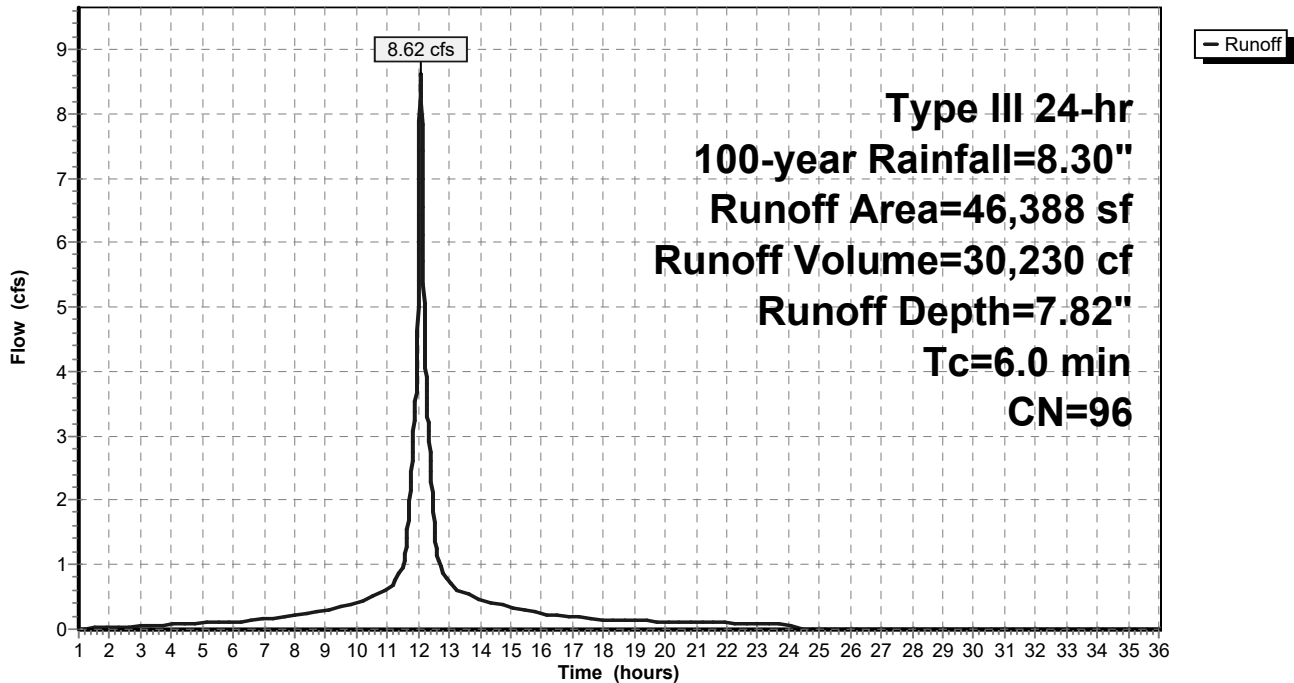

Spofford Post-Development

Prepared by Weston & Sampson

HydroCAD® 10.10-6a s/n 00455 © 2020 HydroCAD Software Solutions LLC

Type III 24-hr 100-year Rainfall=8.30"

Printed 11/5/2021

Page 140

Summary for Subcatchment 16S: Sub 16

Runoff = 2.05 cfs @ 12.08 hrs, Volume= 6,977 cf, Depth= 7.46"
 Routed to Pond 4P : Detention Chambers sC 740

Runoff by SCS TR-20 method, UH=SCS, Weighted-CN, Time Span= 1.00-36.00 hrs, dt= 0.01 hrs
 Type III 24-hr 100-year Rainfall=8.30"

Area (sf)	CN	Description
10,400	98	Paved parking, HSG A
* 822	30	Grass
11,222	93	Weighted Average
822		7.32% Pervious Area
10,400		92.68% Impervious Area

Tc (min)	Length (feet)	Slope (ft/ft)	Velocity (ft/sec)	Capacity (cfs)	Description
6.0					Direct Entry,

Subcatchment 16S: Sub 16

Hydrograph

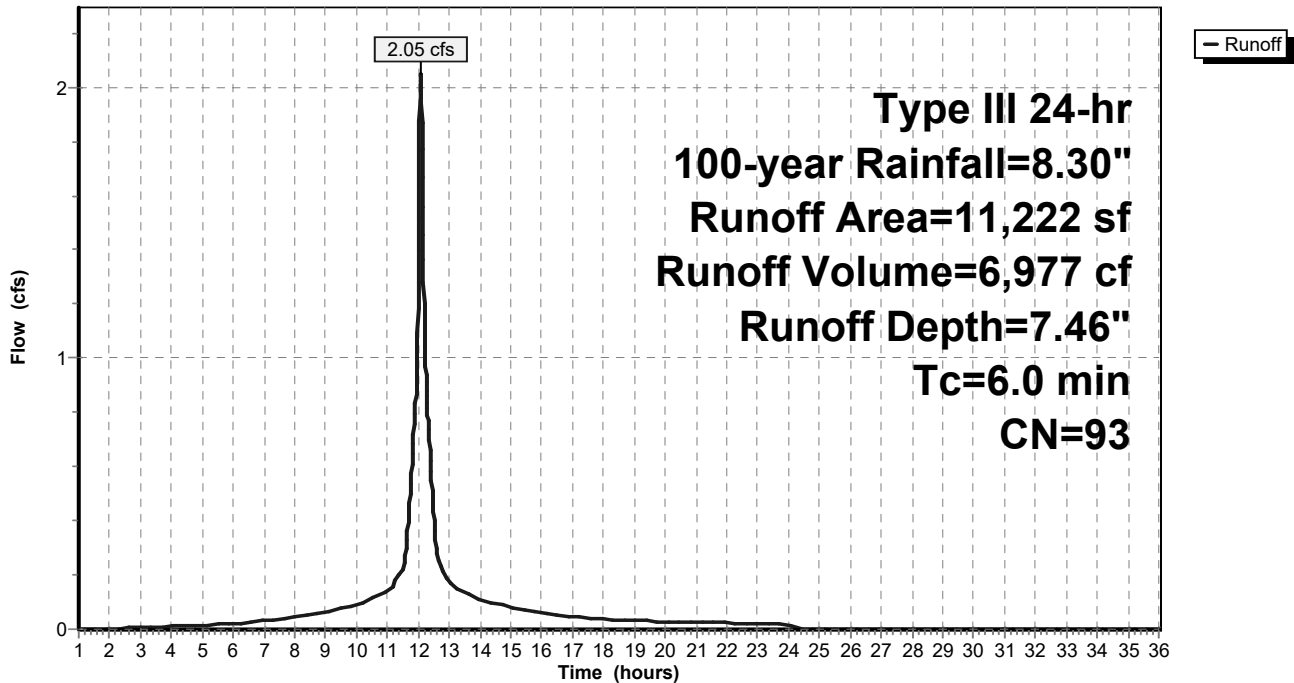

Spofford Post-Development

Prepared by Weston & Sampson

HydroCAD® 10.10-6a s/n 00455 © 2020 HydroCAD Software Solutions LLC

Type III 24-hr 100-year Rainfall=8.30"

Printed 11/5/2021

Page 141

Summary for Subcatchment 17S: Sub 17

Runoff = 2.02 cfs @ 12.08 hrs, Volume= 7,179 cf, Depth> 7.94"
 Routed to Pond 4P : Detention Chambers sC 740

Runoff by SCS TR-20 method, UH=SCS, Weighted-CN, Time Span= 1.00-36.00 hrs, dt= 0.01 hrs
 Type III 24-hr 100-year Rainfall=8.30"

Area (sf)	CN	Description
* 155	30	Grass
10,696	98	Paved parking, HSG A
10,851	97	Weighted Average
155		1.43% Pervious Area
10,696		98.57% Impervious Area

Tc (min)	Length (feet)	Slope (ft/ft)	Velocity (ft/sec)	Capacity (cfs)	Description
6.0					Direct Entry,

Subcatchment 17S: Sub 17

Hydrograph

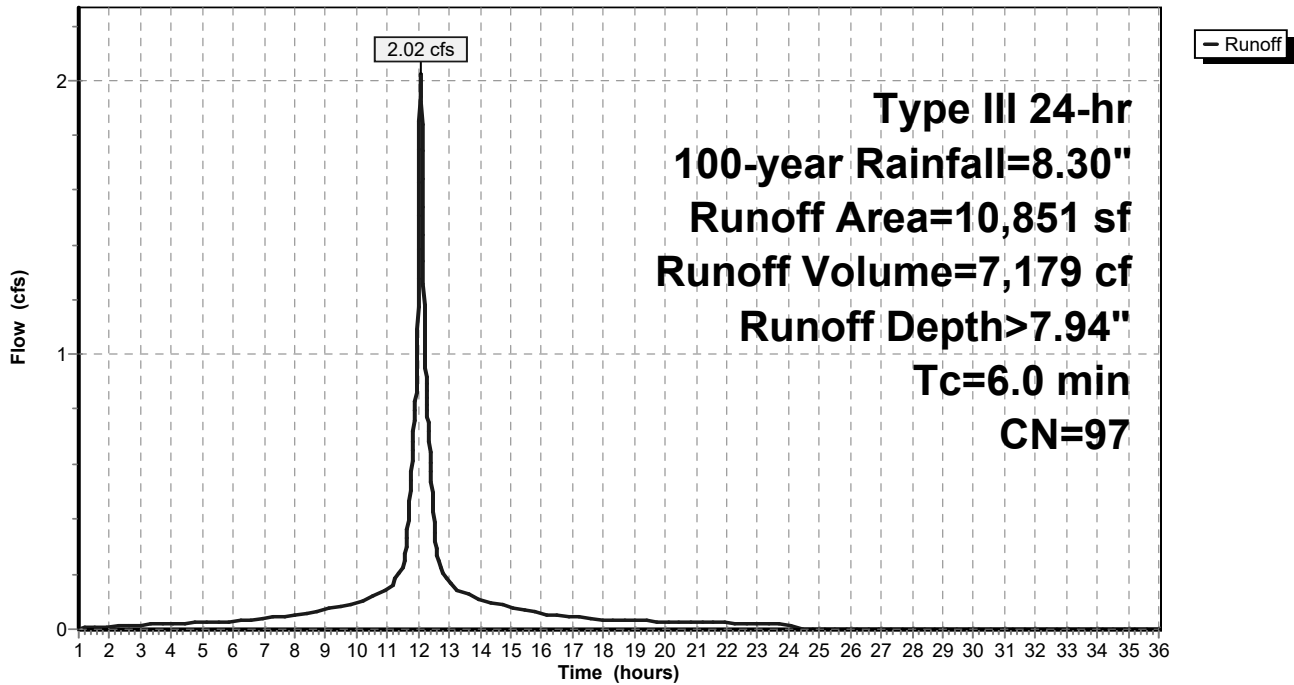

Spofford Post-Development

Prepared by Weston & Sampson

HydroCAD® 10.10-6a s/n 00455 © 2020 HydroCAD Software Solutions LLC

Type III 24-hr 100-year Rainfall=8.30"

Printed 11/5/2021

Page 142

Summary for Subcatchment 18S: Sub 18

Runoff = 0.08 cfs @ 12.30 hrs, Volume= 652 cf, Depth= 0.73"
 Routed to Link 4L : Vernal Pool Wetlands

Runoff by SCS TR-20 method, UH=SCS, Weighted-CN, Time Span= 1.00-36.00 hrs, dt= 0.01 hrs
 Type III 24-hr 100-year Rainfall=8.30"

	Area (sf)	CN	Description
*	5,866	30	Grass
	397	98	Paved parking, HSG A
	4,427	30	Woods, Good, HSG A
	10,690	33	Weighted Average
	10,293		96.29% Pervious Area
	397		3.71% Impervious Area

Tc (min)	Length (feet)	Slope (ft/ft)	Velocity (ft/sec)	Capacity (cfs)	Description
6.0					Direct Entry,

Subcatchment 18S: Sub 18

Hydrograph

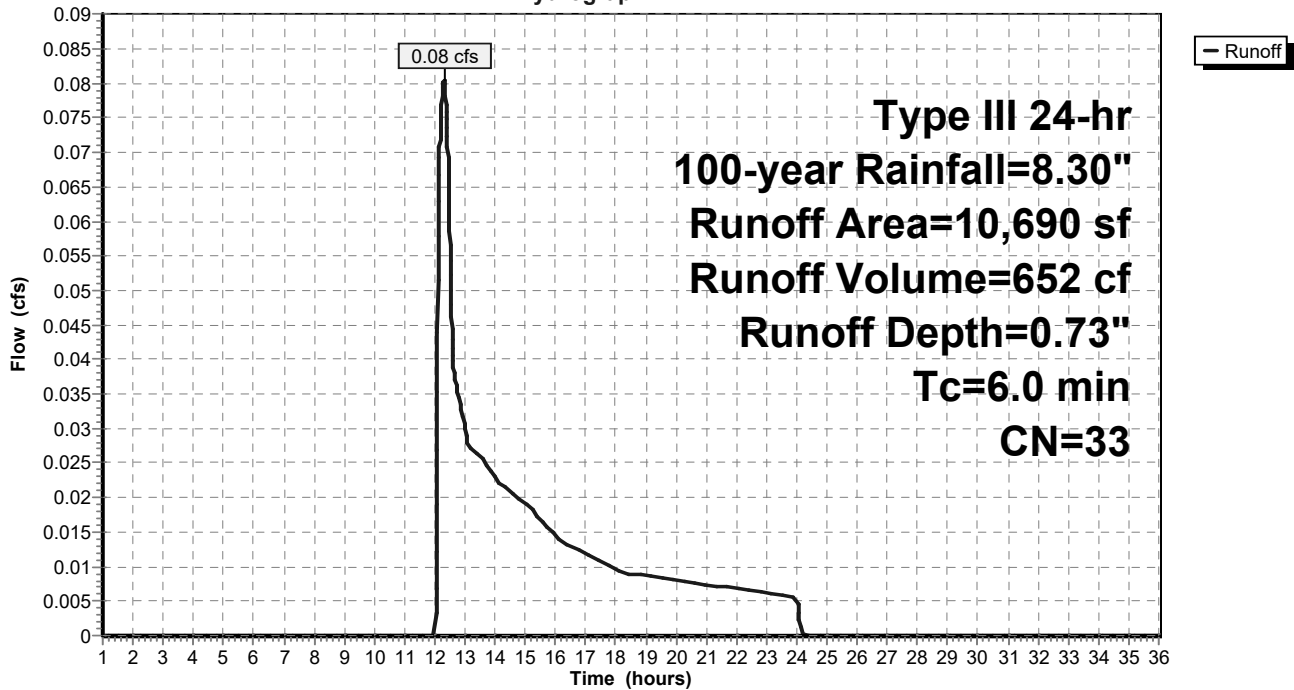

Spofford Post-Development

Prepared by Weston & Sampson

HydroCAD® 10.10-6a s/n 00455 © 2020 HydroCAD Software Solutions LLC

Type III 24-hr 100-year Rainfall=8.30"

Printed 11/5/2021

Page 143

Summary for Subcatchment 19S: Sub 19

Runoff = 0.01 cfs @ 12.39 hrs, Volume= 161 cf, Depth= 0.49"
 Routed to Link 2L : Isolated Wetlands

Runoff by SCS TR-20 method, UH=SCS, Weighted-CN, Time Span= 1.00-36.00 hrs, dt= 0.01 hrs
 Type III 24-hr 100-year Rainfall=8.30"

Area (sf)	CN	Description
* 3,953	30	Grass
3,953		100.00% Pervious Area

Tc (min)	Length (feet)	Slope (ft/ft)	Velocity (ft/sec)	Capacity (cfs)	Description
6.0					Direct Entry,

Subcatchment 19S: Sub 19

Hydrograph

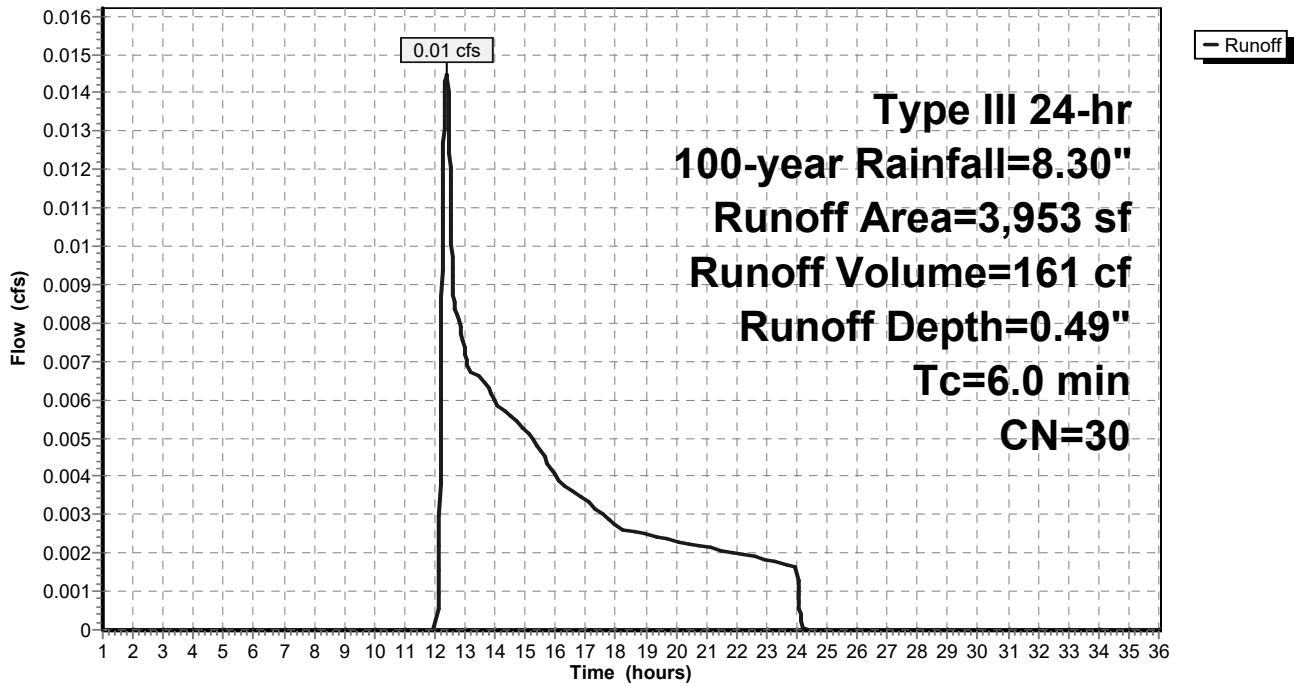

Spofford Post-Development

Prepared by Weston & Sampson

HydroCAD® 10.10-6a s/n 00455 © 2020 HydroCAD Software Solutions LLC

Type III 24-hr 100-year Rainfall=8.30"

Printed 11/5/2021

Page 144

Summary for Pond 3P: Sediment Forebay

Inflow Area = 46,388 sf, 96.62% Impervious, Inflow Depth = 7.82" for 100-year event
 Inflow = 8.62 cfs @ 12.08 hrs, Volume= 30,230 cf
 Outflow = 8.69 cfs @ 12.09 hrs, Volume= 29,856 cf, Atten= 0%, Lag= 0.3 min
 Primary = 8.33 cfs @ 12.09 hrs, Volume= 29,828 cf
 Routed to Pond 4P : Detention Chambers sC 740
 Secondary = 0.36 cfs @ 12.09 hrs, Volume= 28 cf
 Routed to Pond 4P : Detention Chambers sC 740

Routing by Dyn-Stor-Ind method, Time Span= 1.00-36.00 hrs, dt= 0.01 hrs
 Peak Elev= 134.01' @ 12.09 hrs Surf.Area= 1,304 sf Storage= 979 cf

Plug-Flow detention time= 17.8 min calculated for 29,847 cf (99% of inflow)
 Center-of-Mass det. time= 9.7 min (761.3 - 751.7)

Volume	Invert	Avail.Storage	Storage Description
#1	133.00'	979 cf	Custom Stage Data (Irregular) Listed below (Recalc)

Elevation (feet)	Surf.Area (sq-ft)	Perim. (feet)	Inc.Store (cubic-feet)	Cum.Store (cubic-feet)	Wet.Area (sq-ft)
133.00	687	186.0	0	0	687
134.00	1,304	215.0	979	979	1,634

Device	Routing	Invert	Outlet Devices
#1	Primary	128.65'	24.0" Round Culvert L= 29.0' CPP, projecting, no headwall, Ke= 0.900 Inlet / Outlet Invert= 128.65' / 128.50' S= 0.0052 '/' Cc= 0.900 n= 0.013 Corrugated PE, smooth interior, Flow Area= 3.14 sf
#2	Device 1	133.46'	24.0" Horiz. Orifice/Grate C= 0.600 Limited to weir flow at low heads
#3	Secondary	134.00'	215.0' long x 2.0' breadth Broad-Crested Rectangular Weir Head (feet) 0.20 0.40 0.60 0.80 1.00 1.20 1.40 1.60 1.80 2.00 2.50 3.00 3.50 Coef. (English) 2.54 2.61 2.61 2.60 2.66 2.70 2.77 2.89 2.88 2.85 3.07 3.20 3.32

Primary OutFlow Max=8.32 cfs @ 12.09 hrs HW=134.01' TW=130.26' (Dynamic Tailwater)

- ↑1=Culvert (Passes 8.32 cfs of 23.11 cfs potential flow)
- ↑2=Orifice/Grate (Weir Controls 8.32 cfs @ 2.42 fps)

Secondary OutFlow Max=0.34 cfs @ 12.09 hrs HW=134.01' TW=130.26' (Dynamic Tailwater)

- ↑3=Broad-Crested Rectangular Weir (Weir Controls 0.34 cfs @ 0.22 fps)

Pond 3P: Sediment Forebay

Hydrograph

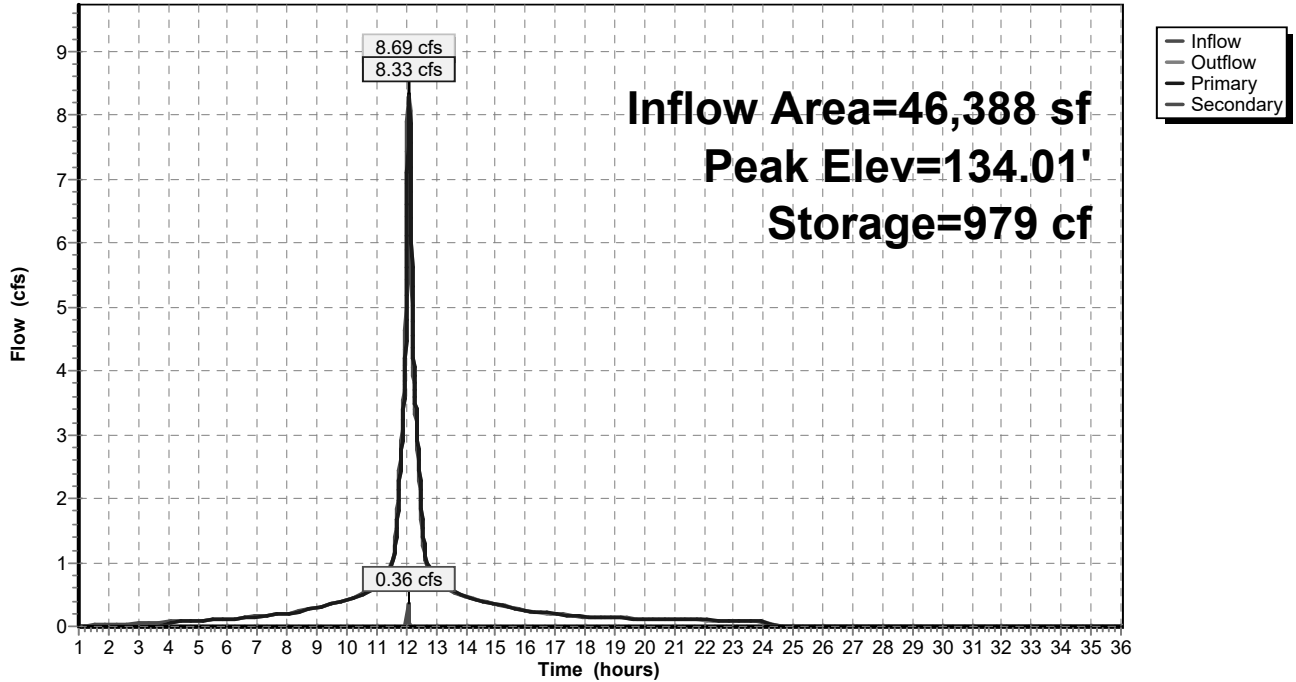

Spofford Post-Development

Prepared by Weston & Sampson

HydroCAD® 10.10-6a s/n 00455 © 2020 HydroCAD Software Solutions LLC

Type III 24-hr 100-year Rainfall=8.30"

Printed 11/5/2021

Page 146

Summary for Pond 4P: Detention Chambers sC 740

Inflow Area = 235,054 sf, 90.09% Impervious, Inflow Depth > 7.24" for 100-year event
 Inflow = 41.40 cfs @ 12.09 hrs, Volume= 141,809 cf
 Outflow = 23.19 cfs @ 12.21 hrs, Volume= 141,436 cf, Atten= 44%, Lag= 7.5 min
 Primary = 23.19 cfs @ 12.21 hrs, Volume= 141,436 cf
 Routed to Link 4L : Vernal Pool Wetlands

Routing by Dyn-Stor-Ind method, Time Span= 1.00-36.00 hrs, dt= 0.01 hrs
 Peak Elev= 132.43' @ 12.21 hrs Surf.Area= 14,134 sf Storage= 30,813 cf

Plug-Flow detention time= 63.6 min calculated for 141,436 cf (100% of inflow)
 Center-of-Mass det. time= 61.8 min (824.5 - 762.7)

Volume	Invert	Avail.Storage	Storage Description
#1A	127.76'	12,437 cf	120.25'W x 117.54'L x 3.50'H Field A 49,468 cf Overall - 18,376 cf Embedded = 31,092 cf x 40.0% Voids
#2A	128.26'	18,376 cf	ADS_StormTech SC-740 +Cap x 400 Inside #1 Effective Size= 44.6"W x 30.0"H => 6.45 sf x 7.12'L = 45.9 cf Overall Size= 51.0"W x 30.0"H x 7.56'L with 0.44' Overlap 400 Chambers in 25 Rows
		30,813 cf	Total Available Storage

Storage Group A created with Chamber Wizard

Device	Routing	Invert	Outlet Devices
#1	Primary	127.66'	24.0" Round Culvert L= 92.0' CPP, projecting, no headwall, Ke= 0.900 Inlet / Outlet Invert= 127.66' / 127.15' S= 0.0055 '/' Cc= 0.900 n= 0.013 Corrugated PE, smooth interior, Flow Area= 3.14 sf
#2	Device 1	127.76'	4.0" Vert. Orifice/Grate C= 0.600 Limited to weir flow at low heads
#3	Device 1	128.39'	4.0' long x 0.5' breadth Broad-Crested Rectangular Weir Head (feet) 0.20 0.40 0.60 0.80 1.00 Coef. (English) 2.80 2.92 3.08 3.30 3.32

Primary OutFlow Max=22.82 cfs @ 12.21 hrs HW=132.31' TW=0.00' (Dynamic Tailwater)

- ↑ **1=Culvert** (Inlet Controls 22.82 cfs @ 7.26 fps)
- ↑ **2=Orifice/Grate** (Passes < 0.88 cfs potential flow)
- ↑ **3=Broad-Crested Rectangular Weir** (Passes < 103.10 cfs potential flow)

Pond 4P: Detention Chambers sC 740

Hydrograph

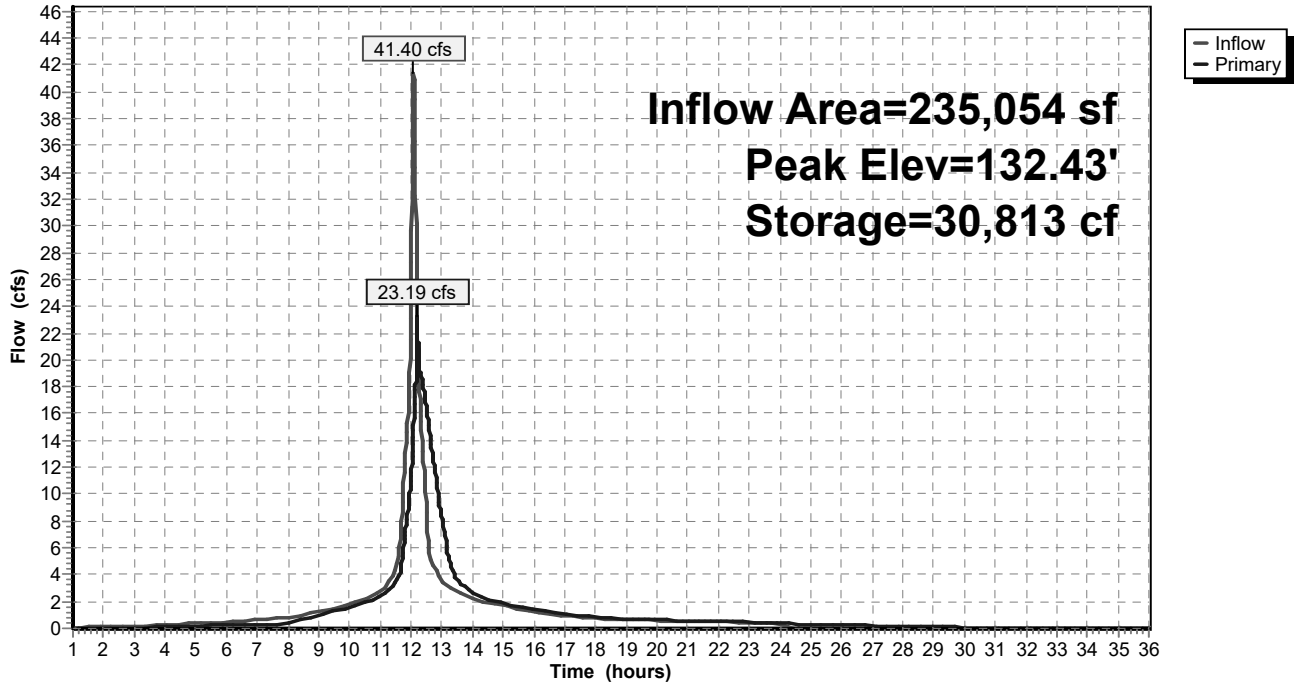

Summary for Link 1L: Leaching CB

Inflow Area = 9,774 sf, 0.00% Impervious, Inflow Depth = 0.49" for 100-year event
Inflow = 0.04 cfs @ 12.39 hrs, Volume= 399 cf
Primary = 0.04 cfs @ 12.39 hrs, Volume= 399 cf, Atten= 0%, Lag= 0.0 min

Primary outflow = Inflow, Time Span= 1.00-36.00 hrs, dt= 0.01 hrs

Link 1L: Leaching CB

Hydrograph

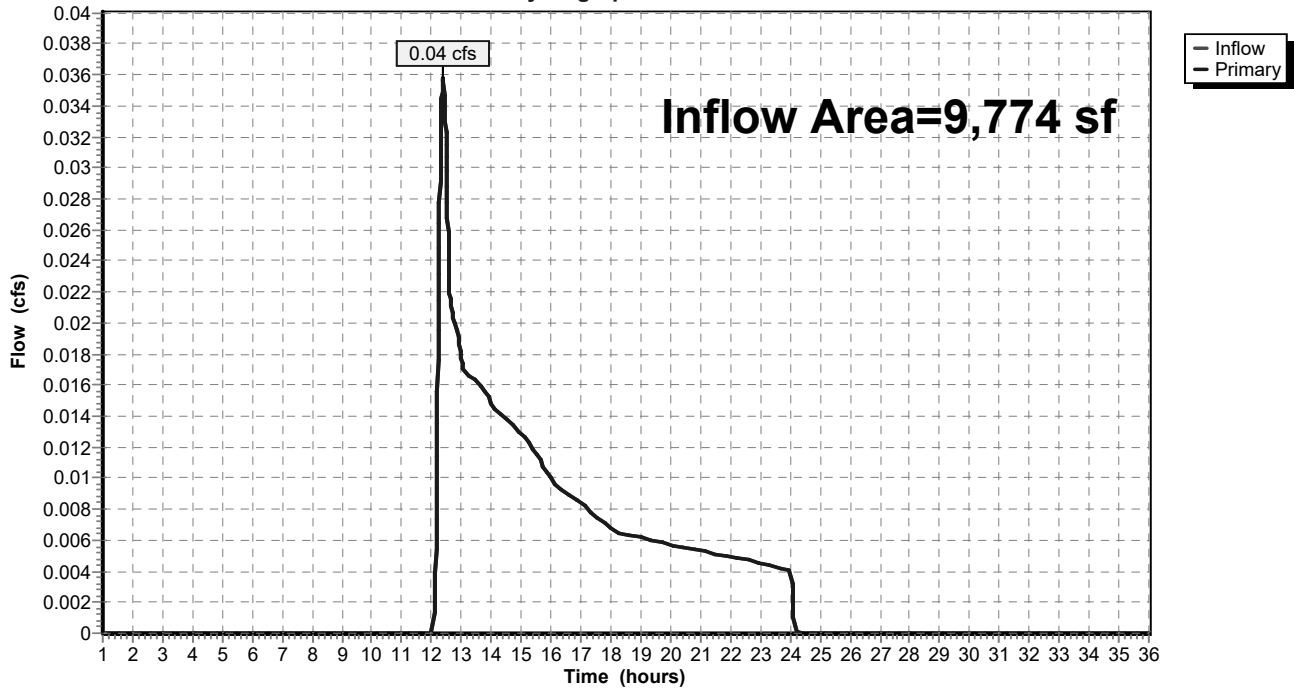

Summary for Link 2L: Isolated Wetlands

Inflow Area = 9,423 sf, 0.00% Impervious, Inflow Depth = 0.49" for 100-year event
Inflow = 0.03 cfs @ 12.39 hrs, Volume= 384 cf
Primary = 0.03 cfs @ 12.39 hrs, Volume= 384 cf, Atten= 0%, Lag= 0.0 min

Primary outflow = Inflow, Time Span= 1.00-36.00 hrs, dt= 0.01 hrs

Link 2L: Isolated Wetlands

Hydrograph

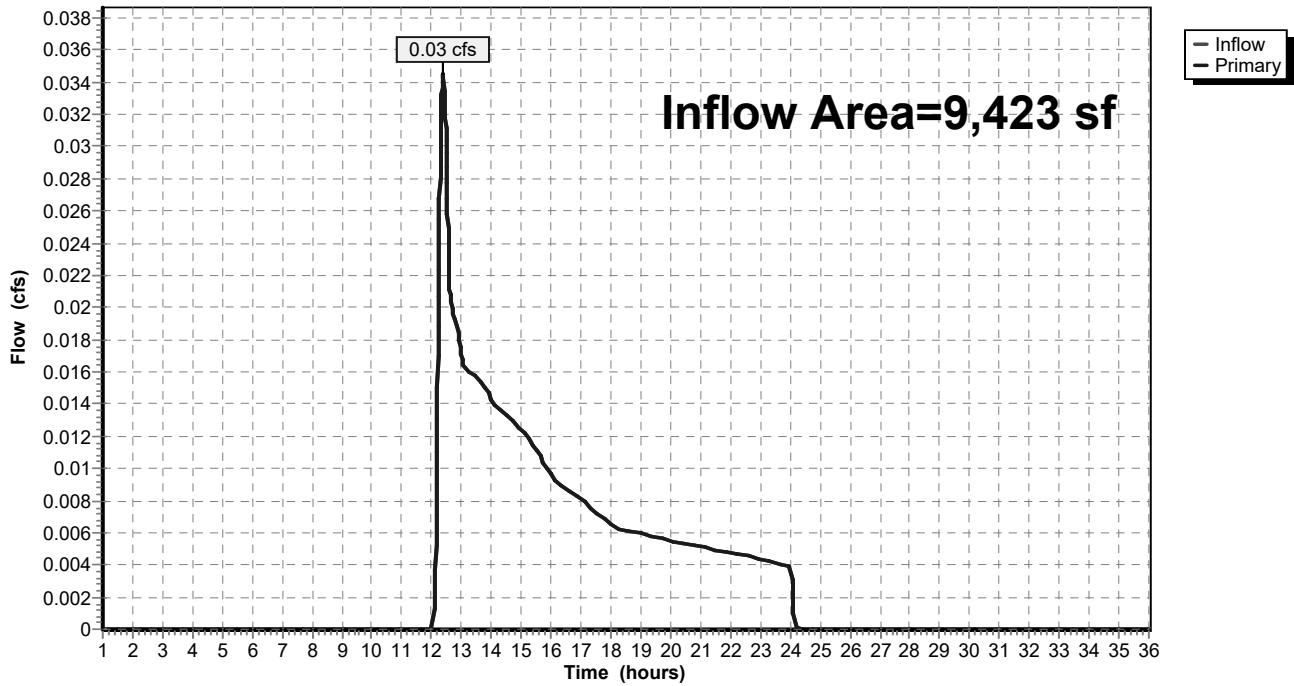

Spofford Post-Development

Prepared by Weston & Sampson

HydroCAD® 10.10-6a s/n 00455 © 2020 HydroCAD Software Solutions LLC

Type III 24-hr 100-year Rainfall=8.30"

Printed 11/5/2021

Page 150

Summary for Link 3L: Spofford Pond Wetlands

Inflow Area = 42,576 sf, 6.11% Impervious, Inflow Depth = 0.84" for 100-year event
Inflow = 0.45 cfs @ 12.12 hrs, Volume= 2,980 cf
Primary = 0.45 cfs @ 12.12 hrs, Volume= 2,980 cf, Atten= 0%, Lag= 0.0 min

Primary outflow = Inflow, Time Span= 1.00-36.00 hrs, dt= 0.01 hrs

Link 3L: Spofford Pond Wetlands

Hydrograph

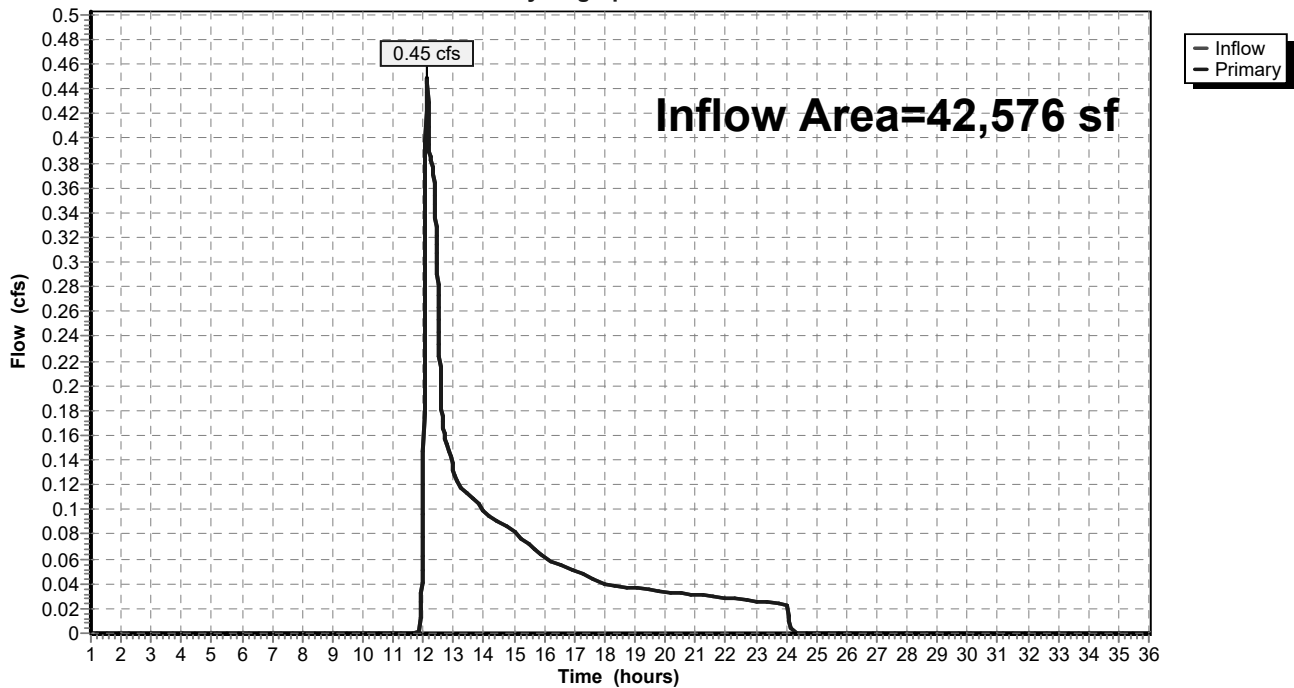

Summary for Link 4L: Vernal Pool Wetlands

Inflow Area = 245,744 sf, 86.33% Impervious, Inflow Depth > 6.94" for 100-year event
Inflow = 23.27 cfs @ 12.21 hrs, Volume= 142,089 cf
Primary = 23.27 cfs @ 12.21 hrs, Volume= 142,089 cf, Atten= 0%, Lag= 0.0 min
Routed to nonexistent node 25L

Primary outflow = Inflow, Time Span= 1.00-36.00 hrs, dt= 0.01 hrs

Link 4L: Vernal Pool Wetlands

Hydrograph

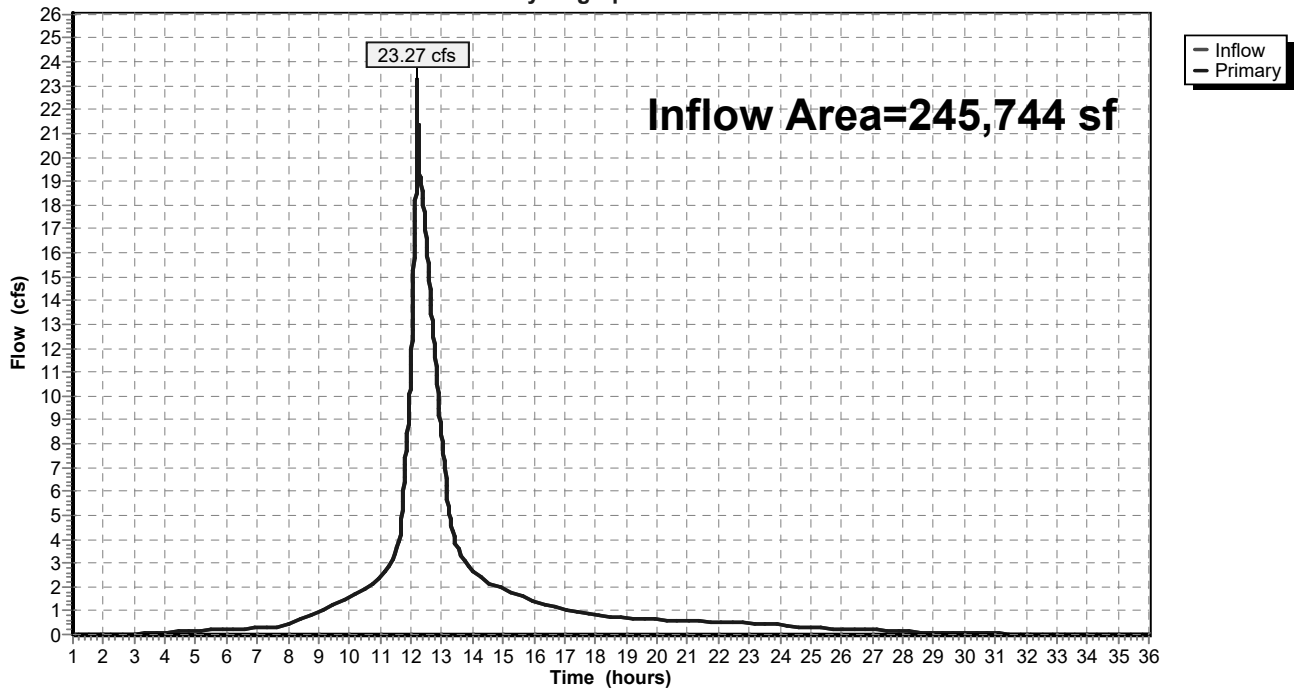

Attachment E - Calculations

**Boxford MA - Spofford Pond School
Preattreatment Volume Calculation**

November 1, 2021

Required Pretreatment Volume Storage

Proposed Paved Area sf x 0.1" x 1/12"= Required WQ Storage CF

Location	Proposed Impervious Area	Required WQ Storage	Provided WQ Storage	Description
Parking Lot C	44820	374	374	Sediment Forebay

Spofford Pond School
Boxford, MA
Calculated By: DKE 11/1/2021

Standard 1: No New Untreated Discharges

Subcatchment	2-yr 24-hr Discharge Velocity (fps)	Discharge Location	Analysis Point	Permissible Velocity (fps)
18S	0.1	Overland flow to slope at southeast	4L	3
4P	4.3	Pipe discharge to ditch at southeast	4L	5

Notes:

1. Velocities calculated using HydroCAD modeling software.
2. Permissible Velocities referenced from the Massachusetts Stormwater Handbook Volume 3 Table 2.3.1 Example of Permissible Velocity Table.

INSTRUCTIONS:

1. In BMP Column, click on Blue Cell to Activate Drop Down Menu
2. Select BMP from Drop Down Menu
3. After BMP is selected, TSS Removal and other Columns are automatically completed.

Version 1, Automated: Mar. 4, 2008

Location:

	B	C	D	E	F
	BMP ¹	TSS Removal Rate ¹	Starting TSS Load*	Amount Removed (C*D)	Remaining Load (D-E)
TSS Removal Calculation Worksheet	Deep Sump and Hooded Catch Basin	0.25	1.00	0.25	0.75
	Subsurface Infiltration Structure	0.80	0.75	0.60	0.15
		0.00	0.15	0.00	0.15
		0.00	0.15	0.00	0.15
		0.00	0.15	0.00	0.15

Total TSS Removal =

Separate Form Needs to be Completed for Each Outlet or BMP Train

Project:
 Prepared By:
 Date:

*Equals remaining load from previous BMP (E) which enters the BMP

Non-automated TSS Calculation Sheet must be used if Proprietary BMP Proposed
 1. From MassDEP Stormwater Handbook Vol. 1

INSTRUCTIONS:

1. In BMP Column, click on Blue Cell to Activate Drop Down Menu
2. Select BMP from Drop Down Menu
3. After BMP is selected, TSS Removal and other Columns are automatically completed.

Version 1, Automated: Mar. 4, 2008

Location:

	B	C	D	E	F
	BMP ¹	TSS Removal Rate ¹	Starting TSS Load*	Amount Removed (C*D)	Remaining Load (D-E)
TSS Removal Calculation Worksheet	Sediment Forebay	0.25	1.00	0.25	0.75
	Subsurface Infiltration Structure	0.80	0.75	0.60	0.15
		0.00	0.15	0.00	0.15
		0.00	0.15	0.00	0.15
		0.00	0.15	0.00	0.15

Total TSS Removal =

Separate Form Needs to be Completed for Each Outlet or BMP Train

Project:
 Prepared By:
 Date:

*Equals remaining load from previous BMP (E) which enters the BMP

Non-automated TSS Calculation Sheet must be used if Proprietary BMP Proposed
 1. From MassDEP Stormwater Handbook Vol. 1

Spofford Pond School WQF Statement

There are two stormwater management practices proposed at the Spofford Pond School site. A sediment forebay located within the parking lot southeast of the existing building and an underground stormtech chamber system located east of the existing building. The sediment forebay provides pretreatment and attenuates flows prior to discharge to the underground stormtech chamber system. The sediment forebay meets the required pretreatment volume. The underground stormtech system treats and attenuates collected flow prior to discharge offsite.

As opposed to providing the Water Quality Volume for the 1" storm below the lowest outlet of the entirety of the underground chamber system, the Water Quality Flow requirement for the 1" storm is met by the proposed isolator rows. The proposed isolator rows are sized to treat the "first flush" and is sized based on a flow rate basis. Providing adequate storage capacity within the isolator rows for the Water Quality Flow is beneficial because the isolator rows provide enhanced suspended solids and pollutant removal. Based on the provided isolator row sizing calculations within this report, the peak elevation of the 1" storm within the chamber system will not exceed the elevation of the diversion weir within the OCS-2 structure. This will ensure that the entirety of the 1" storm will enter the isolator row, and storms in excess of the 1" storm will by-pass the isolator rows and will enter the remaining chambers within the underground system. The following letter provided by the Maine Department of Environmental Protection as well as the Technical Memo provided by the chamber manufacturer provide additional information on the configuration of the underground stormtech chamber system as well as the calculation methods used in the analysis of the isolator rows.



PAUL R. LEPAGE
GOVERNOR

STATE OF MAINE
DEPARTMENT OF
ENVIRONMENTAL PROTECTION



PAUL MERCER
COMMISSIONER

July 29, 2016

StormTech, A Division of ADS, Inc.
70 Inwood Road, Suite 3
Rocky Hill, CT 06067
ATTN: David Mailhot P.E.

Dear Mr. Mailhot,

This letter replaces the letter dated March 22, 2016. It includes a slight modification in section 1 to clarify sizing requirements.

The Stormtech Isolator Row was approved by the Department of Environmental Protection (Department) in September 2009 for use as a pre-treatment row before a subsurface underdrained filter system as described in Chapter 7.3 of Volume III of the Maine Stormwater Management Best Management Practice Manual. The sizing, installation, and maintenance criteria provided in this letter replace the ones given in Chapter 7.3 of Volume III of the Maine Stormwater Management BMP Manual. The Department still authorizes the use of the StormTech Isolator Row as a pre-treatment row meeting the requirements of the General Standards (Section 4.C.) of the Stormwater Management Rules (Chapter 500) provided the system is sized, installed, and maintained in accordance with the following provisions:

1. The number of chambers within the Isolator Row pre-treatment structure must treat, without overflowing, the one-year 24-hour peak flow from the structure's drainage area. To determine the number of chambers, the one-year peak flow rate must be divided by the specific flow rate of the chamber. The acceptable flow rate for each of the Isolator Row chamber sizes are as follow:

Chamber size	Flow Rate
SC-310	0.1 cfs
SC-740 or DC-780	0.2 cfs
MC-3500	0.3 cfs

Additional pre-treatment rows may be added based on site conditions and chamber bed layout provided each row is provided with access manhole and control structures.

2. The Isolator Row must be part of a stormwater management system that conforms to all the requirements of Chapter 7.3 of the Stormwater Management Manual and be fitted with an overflow that bypasses the pretreatment Isolator Row only when the one-year 24-hour peak flow is exceeded, and discharges to a stable outlet or is directed to a detention system/structure that will provide necessary flood storage.
3. The Isolator Row shall be underlain with a bottom surface consisting of two layers of ADS 315 woven geotextile or equivalent; and be covered with one layer of ADS 601T non-woven geotextile or equivalent.
4. The Isolator Row does not provide for the removal of hydrocarbons and should be preceded by a device or practice that will serve this function if the area draining to the Isolator Row is

AUGUSTA
17 STATE HOUSE STATION
AUGUSTA, MAINE 04333-0017
(207) 287-7688 FAX: (207) 287-7826

BANGOR
106 HOGAN ROAD, SUITE 6
BANGOR, MAINE 04401
(207) 941-4570 FAX: (207) 941-4584

PORTLAND
312 CANCO ROAD
PORTLAND, MAINE 04103
(207) 822-6300 FAX: (207) 822-6303

PRESQUE ISLE
1235 CENTRAL DRIVE, SKYWAY PARK
PRESQUE ISLE, MAINE 04769
(207) 764-0477 FAX: (207) 760-3143

web site: www.maine.gov/dep

Letter to Mr. Mailhot
(March 22, 2016)
Page 2 of 2

a likely source of hydrocarbons (i.e. parking lots, roads, drive-through commercial enterprises).

5. The Isolator Row must include an access at both ends for the removal of accumulated sediment and debris.
6. The first year of system maintenance must be provided by the manufacturer to ensure that the system is operating according to the established specifications.
7. Prior to construction, a five-year binding inspection and maintenance contract must be provided for review and approval by the Department, and must be renewed before contract expiration. The contract will be with a professional with knowledge of erosion and stormwater control, including a detailed working knowledge of the proposed system.
8. The overall stormwater management design must meet all Department criteria and sizing specifications and will be reviewed and approved by the Department prior to use.
9. Each project must be reviewed and approved by the manufacturer for proposed use, layout and sizing of the pre-treatment row and for conformance with their design specifications.
10. The pre-treatment row must be installed under the manufacturer's representative supervision.
11. This approval is conditional to on-the-ground experience confirming that the StormTech Isolator Row system's pollutant removal efficiency is appropriate. The "permit shield" provision (Section 14) of the Chapter 500 rules will apply, and the Department will not require the replacement of the system if, with proper maintenance, pollutant removals do not satisfy the General Standard Best Management Practices.

We look forward to working with you as these stormwater management structures are installed on new projects. Questions concerning this decision should be directed to Marianne Hubert at (207) 215-6485 or Jeff Dennis at (207) 215-6376.

Sincerely,

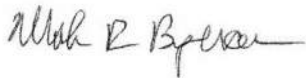

Mark Bergeron, P.E.
Director
Bureau of Land Resources

Cc: Don Witherill, Maine DEP
Gregg Novick, Stormwater Compliance LLC
John Whitehouse, Advanced Drainage Systems, Inc.

StormTech and Stormwater Quality

StormTech's patented Isolator™ Row is a row of chambers wrapped in a geotextile which filters the stormwater trapping pollutants in the row. The Isolator Row provides a way to inspect and maintain the system.

Isolator Row Detail

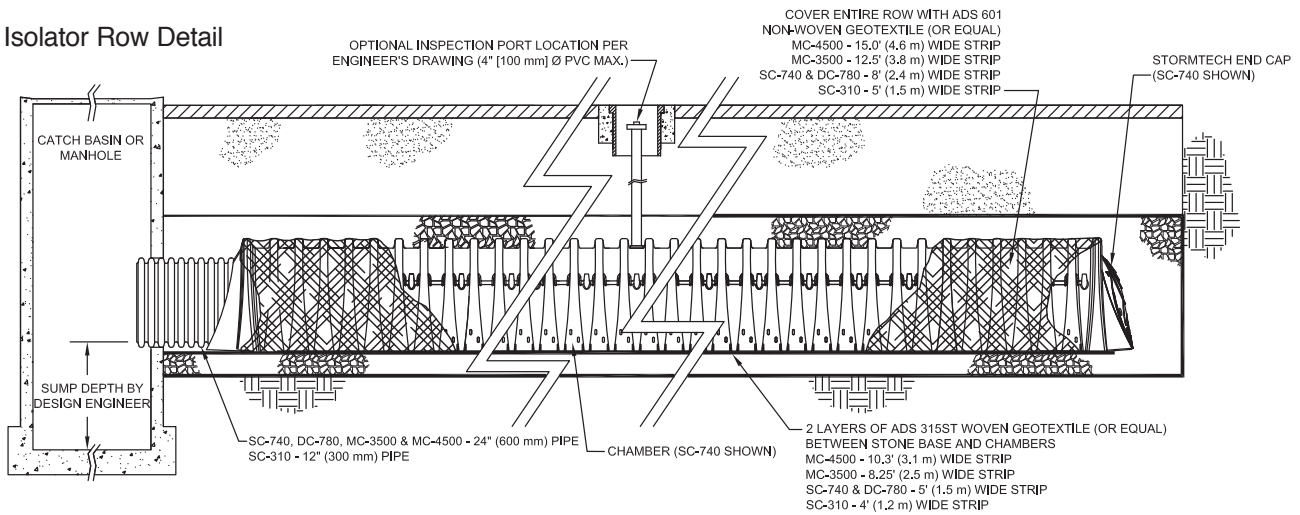

Note: For many applications, the non-woven geotextile over the DC-780, MC-3500 and MC-4500 Isolator Row chambers can be eliminated or substituted with the AASHTO Class 1 woven geotextile. Contact your StormTech representative for assistance.

Isolator Row Field Verification Testing at the University of New Hampshire Stormwater Center

- Field testing (TARP tier II protocol) of the Isolator Row has been ongoing since December 2006.
- Removal efficiencies for TSS have improved as the filter cake has built up on the bottom fabric of the Isolator Row.
- Current data shows a TSS removal efficiency which exceeds 80%.

Removal Efficiency Results:

- Total Suspended Solids = 80%
- Phosphorous = 49%
- Total Petroleum Hydrocarbons = 90%
- Zinc = 53%

This system achieves a removal efficiency of 80% for TSS which meets most municipal recommended levels for water quality treatment.



Inspection and Maintenance

The Isolator Row can be inspected through the upstream manhole or optional inspection port.

Maintenance is easily accomplished with the JetVac process.

The frequency of inspection and maintenance varies by location. Contact StormTech for assistance with inspection and maintenance scheduling.



Technical Memo

Pages: 3

To: Ed Pisowicz

From: Ken Sanok, P.E.

Cc: Engineering Department, Technical Services,
 StormTech Regional Product Managers

Date: 03/5/2010

Subject: Design Guidance for the Isolator Row Weir

Isolator Row

The Isolator Row is typically designed to treat the "first flush" and offers the versatility to be sized on a volume basis or flow rate basis. While the "first flush" will have the highest TSS, nutrient and hydrocarbon loading the unique design of the Isolator Row system continues to filter throughout the entire storm event. An upstream manhole/diversion structure not only provides access to the Isolator Row but typically includes a high flow weir such that the stormwater flow rates or volumes that exceed the capacity of the Isolator Row chambers overtop the weir and discharge through a manifold to the remainder of the chamber bed. There are several methods to divert the "first flush" into the Isolator Row (weirs, varying pipe inverts, etc.). This memo addresses the design of a weir for the Isolator Row diversion structure.

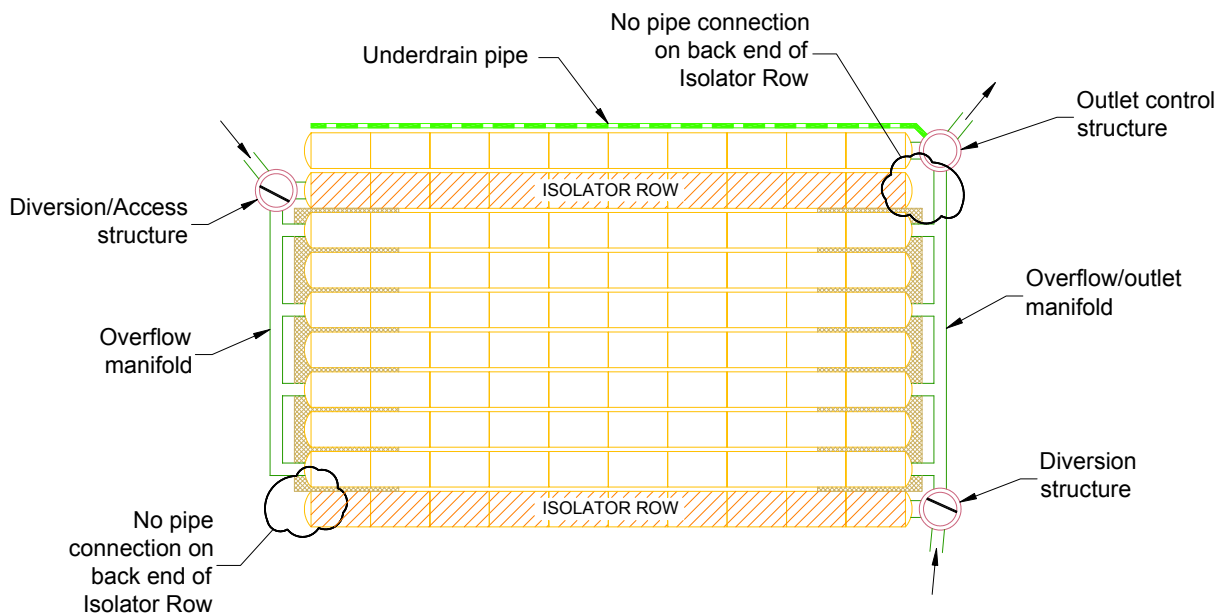

Figure 1 Typical StormTech Chamber Layout with Isolator Row

Structure Placement

The diversion/access structure must be placed directly in front of the Isolator Row and must be connected by a 24" pipe to the SC-740, DC-780 and MC-3500 chambers and a 12" pipe to the SC-310 chamber. The structure will typically have a weir installed and a minimum size of 48 inches is recommended to allow access to the Isolator Row. The design engineer may select a smaller size structure for shallow systems with low flow rates. The actual size of the structure will vary based on the weir design, pipe sizes, pipe angles and design flow rate.

Diversion Weir

The weir is situated to divert the runoff initially into the Isolator Row. The maximum weir crest elevation is determined by subtracting the head required to pass the peak flow from the maximum allowable water surface elevation. Typically the weir crest elevation ranges from the midpoint of the chamber up to the top of the chamber (see figure 2). The design of the weir is performed in several steps. The desired sized structure is drawn on the engineer's plans with the pipe connections. A weir is drawn in and the length is determined. The design engineer then determines the allowable water surface elevation over the weir crest in the structure (typically it is set at the same elevation as the top of the stone above the chambers). The weir crest elevation is then estimated. Start by assuming the elevation of the weir crest is at the same elevation as the top of the chambers. Thus the approach head (H) is the distance from the weir crest to the allowable water surface elevation.

The equation of a sharp crested weir can be written as follows ^[1]:

$$Q = C \sqrt{2g} LH^{3/2}$$

$$C = 0.40 + 0.05 \frac{H}{P}$$

Q = flow rate (cfs)

C = discharge coefficient

L = length of weir (ft)

H = approach head on the crest (ft)

P = height of crest above channel bottom (ft)

g = gravity (32.2 ft/s²)

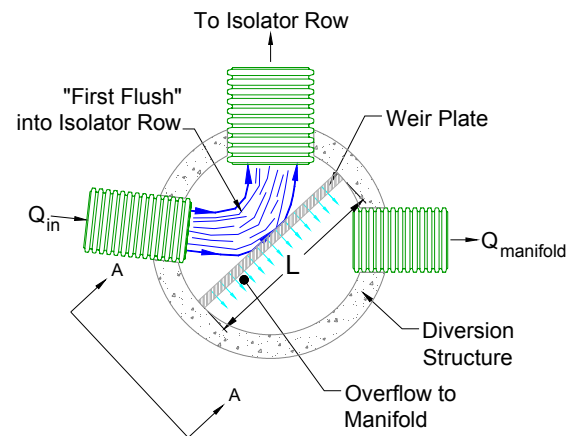

Figure 2A, Plan View of Diversion Structure

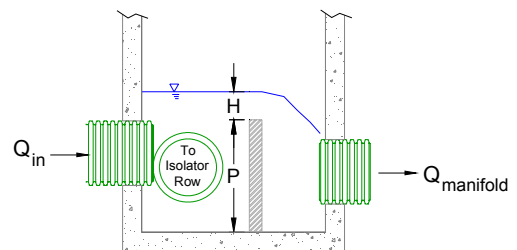

Figure 2B, Section A-A of Diversion Structure

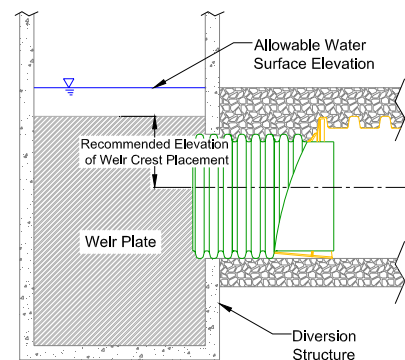

Figure 2C, Profile of Diversion Structure and Isolator Row

The flow over the weir can be calculated using these equations. This calculated flow is then compared to the design flow rate entering the structure. If this calculated flow is greater than the design flow rate then the weir is sufficient to pass the flows. If not, then the weir crest can be lowered and the calculations repeated. As mentioned previously StormTech recommends the weir crest be set between the top of the chamber and the midpoint of the chamber (see figure 2C). If the lowered crest cannot meet the design flow rate a larger structure can be analyzed which allows for a longer weir crest.

Other Considerations

StormTech does not have any specifications for the material or structural design of the weir. It is the responsibility of the design engineer to ensure a material/design selected is adequate for the project design parameters. StormTech has found that aluminum weirs work well as the Isolator Row diversion weir.

Due to the confined nature of the structures it is possible that the weir will be suppressed and/or contracted. The design engineer must be aware of this and incorporate it into the design if deemed necessary.

- [1] Cassidy, J.J, Chaudhry, M.H., and Roberson, J.A., Hydraulic Engineering, 1st ed., Houghton Mifflin, Boston, 1988

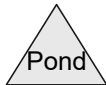
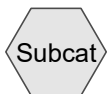
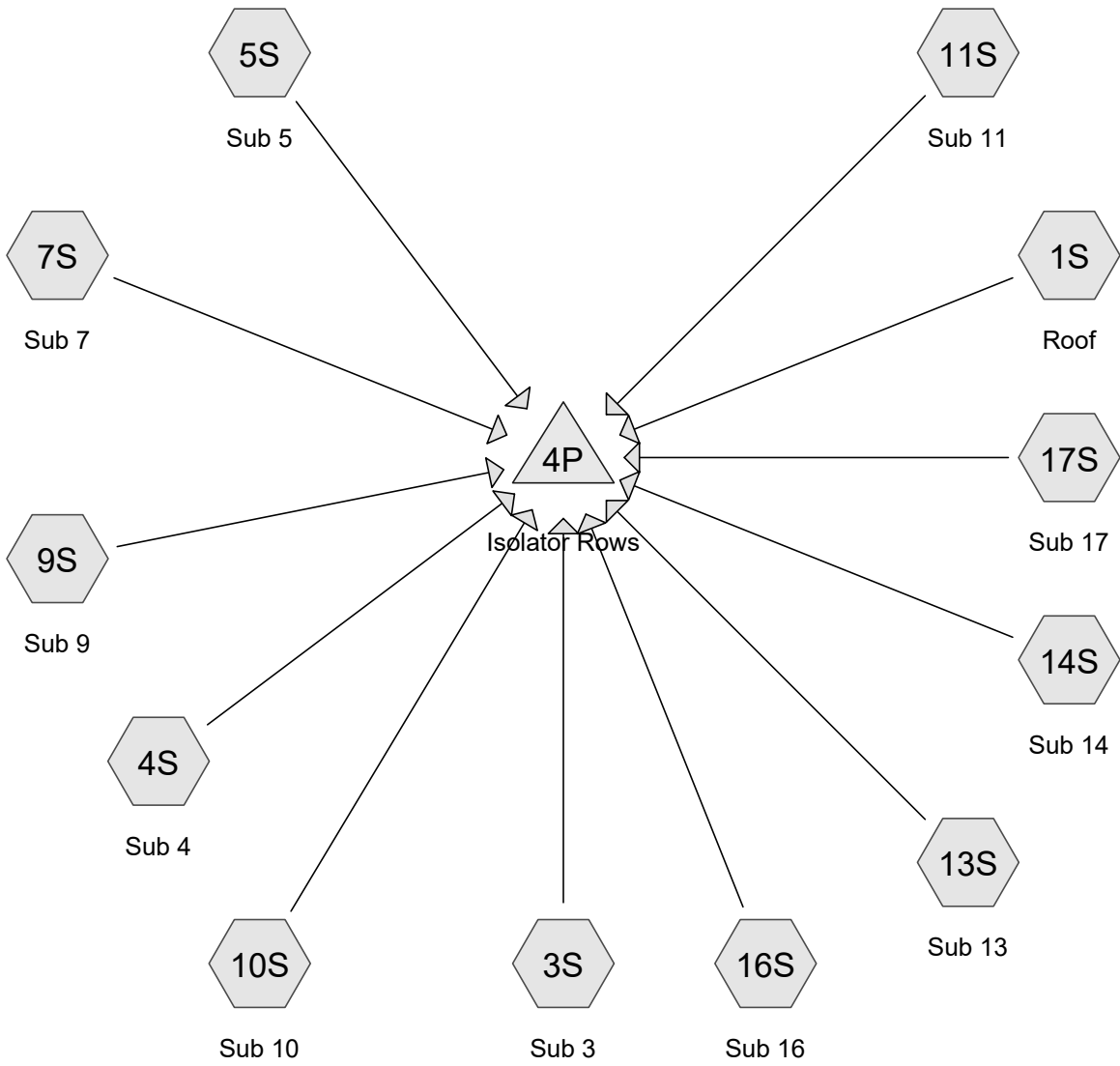

Routing Diagram for Spofford Isolator Sizing
 Prepared by Weston & Sampson, Printed 11/5/2021
 HydroCAD® 10.10-6a s/n 00455 © 2020 HydroCAD Software Solutions LLC

Spofford Isolator Sizing

Prepared by Weston & Sampson

HydroCAD® 10.10-6a s/n 00455 © 2020 HydroCAD Software Solutions LLC

Printed 11/5/2021

Page 2

Rainfall Events Listing (selected events)

Event#	Event Name	Storm Type	Curve	Mode	Duration (hours)	B/B	Depth (inches)	AMC
1	1"	Type III 24-hr		Default	24.00	1	1.00	2

Spofford Isolator Sizing

Prepared by Weston & Sampson

HydroCAD® 10.10-6a s/n 00455 © 2020 HydroCAD Software Solutions LLC

Printed 11/5/2021

Page 3

Area Listing (all nodes)

Area (sq-ft)	CN	Description (subcatchment-numbers)
18,358	30	Grass (3S, 4S, 5S, 9S, 10S, 11S, 13S, 14S, 16S, 17S)
85,580	98	Paved parking, HSG A (3S, 4S, 5S, 7S, 9S, 10S, 11S, 13S, 14S, 16S, 17S)
71,161	98	Roofs, HSG A (1S)
9,104	98	Turf (impervious) (3S)
3,378	30	Woods, Good, HSG A (3S, 4S, 10S)
187,581	90	TOTAL AREA

Spofford Isolator Sizing

Prepared by Weston & Sampson

HydroCAD® 10.10-6a s/n 00455 © 2020 HydroCAD Software Solutions LLC

Printed 11/5/2021

Page 4

Soil Listing (all nodes)

Area (sq-ft)	Soil Group	Subcatchment Numbers
160,119	HSG A	1S, 3S, 4S, 5S, 7S, 9S, 10S, 11S, 13S, 14S, 16S, 17S
0	HSG B	
0	HSG C	
0	HSG D	
27,462	Other	3S, 4S, 5S, 9S, 10S, 11S, 13S, 14S, 16S, 17S
187,581		TOTAL AREA

Spofford Isolator Sizing

Prepared by Weston & Sampson

HydroCAD® 10.10-6a s/n 00455 © 2020 HydroCAD Software Solutions LLC

Printed 11/5/2021

Page 5

Ground Covers (all nodes)

HSG-A (sq-ft)	HSG-B (sq-ft)	HSG-C (sq-ft)	HSG-D (sq-ft)	Other (sq-ft)	Total (sq-ft)	Ground Cover	Subcatchm Numbers
0	0	0	0	18,358	18,358	Grass	
85,580	0	0	0	0	85,580	Paved parking	
71,161	0	0	0	0	71,161	Roofs	
0	0	0	0	9,104	9,104	Turf (impervious)	
3,378	0	0	0	0	3,378	Woods, Good	
160,119	0	0	0	27,462	187,581	TOTAL AREA	

Spofford Isolator Sizing

Prepared by Weston & Sampson

HydroCAD® 10.10-6a s/n 00455 © 2020 HydroCAD Software Solutions LLC

Printed 11/5/2021

Page 6

Pipe Listing (all nodes)

Line#	Node Number	In-Invert (feet)	Out-Invert (feet)	Length (feet)	Slope (ft/ft)	n	Width (inches)	Diam/Height (inches)	Inside-Fill (inches)
1	4P	127.66	127.15	92.0	0.0055	0.013	0.0	24.0	0.0
2	4P	128.27	128.27	48.0	0.0000	0.013	0.0	18.0	0.0

Spofford Isolator Sizing

Prepared by Weston & Sampson

HydroCAD® 10.10-6a s/n 00455 © 2020 HydroCAD Software Solutions LLC

Type III 24-hr 1" Rainfall=1.00"

Printed 11/5/2021

Page 7

Time span=0.00-72.00 hrs, dt=0.01 hrs, 7201 points
Runoff by SCS TR-20 method, UH=SCS, Weighted-Q
Reach routing by Dyn-Stor-Ind method - Pond routing by Dyn-Stor-Ind method

Subcatchment1S: Roof	Runoff Area=71,161 sf 100.00% Impervious Runoff Depth=0.79" Tc=6.0 min CN=98 Runoff=1.45 cfs 4,690 cf
Subcatchment3S: Sub 3	Runoff Area=24,730 sf 73.09% Impervious Runoff Depth=0.58" Tc=6.0 min CN=WQ Runoff=0.37 cfs 1,191 cf
Subcatchment4S: Sub 4	Runoff Area=13,951 sf 62.30% Impervious Runoff Depth=0.49" Tc=6.0 min CN=WQ Runoff=0.18 cfs 573 cf
Subcatchment5S: Sub 5	Runoff Area=9,699 sf 79.03% Impervious Runoff Depth=0.63" Tc=6.0 min CN=WQ Runoff=0.16 cfs 505 cf
Subcatchment7S: Sub 7	Runoff Area=2,469 sf 100.00% Impervious Runoff Depth=0.79" Tc=6.0 min CN=98 Runoff=0.05 cfs 163 cf
Subcatchment9S: Sub 9	Runoff Area=10,942 sf 96.30% Impervious Runoff Depth=0.76" Tc=6.0 min CN=WQ Runoff=0.22 cfs 694 cf
Subcatchment10S: Sub 10	Runoff Area=18,532 sf 69.05% Impervious Runoff Depth=0.55" Tc=6.0 min CN=WQ Runoff=0.26 cfs 843 cf
Subcatchment11S: Sub 11	Runoff Area=6,808 sf 98.43% Impervious Runoff Depth=0.78" Tc=6.0 min CN=WQ Runoff=0.14 cfs 442 cf
Subcatchment13S: Sub 13	Runoff Area=3,318 sf 87.70% Impervious Runoff Depth=0.69" Tc=6.0 min CN=WQ Runoff=0.06 cfs 192 cf
Subcatchment14S: Sub 14	Runoff Area=3,898 sf 96.02% Impervious Runoff Depth=0.76" Tc=6.0 min CN=WQ Runoff=0.08 cfs 247 cf
Subcatchment16S: Sub 16	Runoff Area=11,222 sf 92.68% Impervious Runoff Depth=0.73" Tc=6.0 min CN=WQ Runoff=0.21 cfs 685 cf
Subcatchment17S: Sub 17	Runoff Area=10,851 sf 98.57% Impervious Runoff Depth=0.78" Tc=6.0 min CN=WQ Runoff=0.22 cfs 705 cf
Pond 4P: Isolator Rows	Peak Elev=130.24' Storage=3,424 cf Inflow=3.39 cfs 10,931 cf Outflow=0.64 cfs 10,932 cf

Total Runoff Area = 187,581 sf Runoff Volume = 10,931 cf Average Runoff Depth = 0.70"
11.59% Pervious = 21,736 sf 88.41% Impervious = 165,845 sf

Spofford Isolator Sizing

Prepared by Weston & Sampson

HydroCAD® 10.10-6a s/n 00455 © 2020 HydroCAD Software Solutions LLC

Type III 24-hr 1" Rainfall=1.00"

Printed 11/5/2021

Page 8

Summary for Subcatchment 1S: Roof

Runoff = 1.45 cfs @ 12.08 hrs, Volume= 4,690 cf, Depth= 0.79"

Routed to Pond 4P : Isolator Rows

Runoff by SCS TR-20 method, UH=SCS, Weighted-Q, Time Span= 0.00-72.00 hrs, dt= 0.01 hrs
Type III 24-hr 1" Rainfall=1.00"

Area (sf)	CN	Description
71,161	98	Roofs, HSG A
71,161		100.00% Impervious Area

Tc (min)	Length (feet)	Slope (ft/ft)	Velocity (ft/sec)	Capacity (cfs)	Description
6.0					Direct Entry,

Subcatchment 1S: Roof

Hydrograph

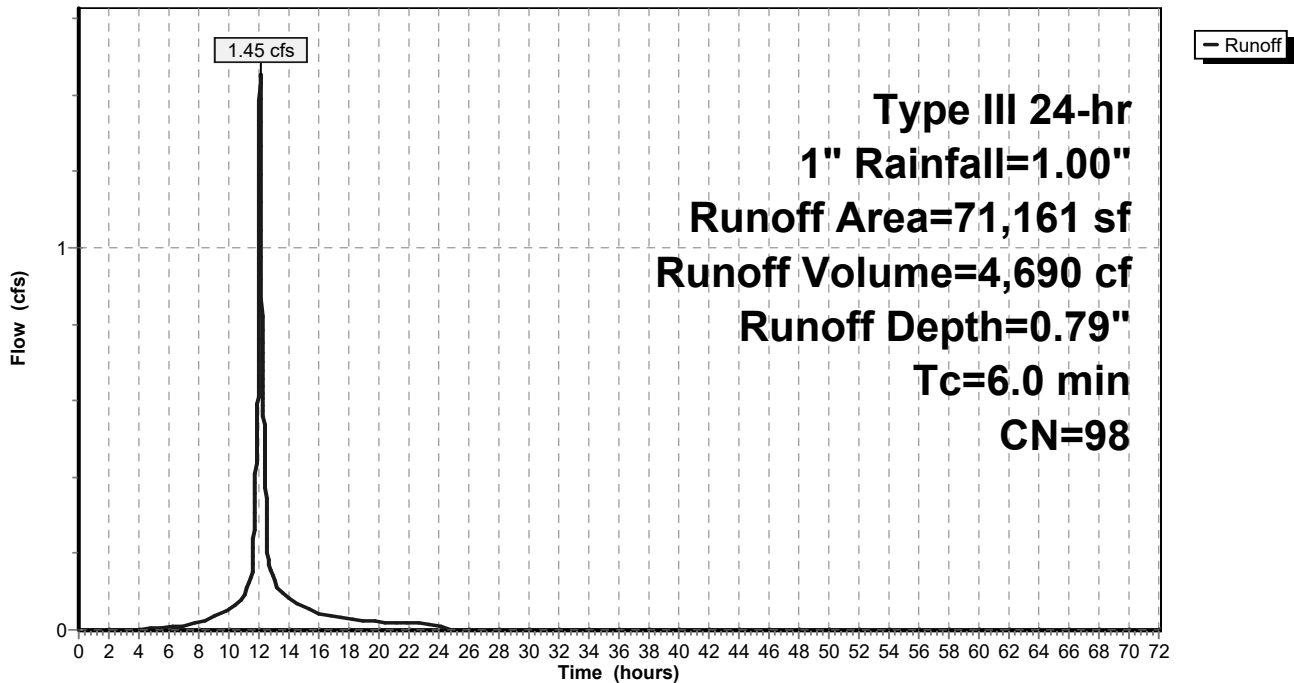

Spofford Isolator Sizing

Prepared by Weston & Sampson

HydroCAD® 10.10-6a s/n 00455 © 2020 HydroCAD Software Solutions LLC

Type III 24-hr 1" Rainfall=1.00"

Printed 11/5/2021

Page 9

Summary for Subcatchment 3S: Sub 3

Runoff = 0.37 cfs @ 12.08 hrs, Volume= 1,191 cf, Depth= 0.58"
 Routed to Pond 4P : Isolator Rows

Runoff by SCS TR-20 method, UH=SCS, Weighted-Q, Time Span= 0.00-72.00 hrs, dt= 0.01 hrs
 Type III 24-hr 1" Rainfall=1.00"

Area (sf)	CN	Description
8,972	98	Paved parking, HSG A
* 9,104	98	Turf (impervious)
* 5,760	30	Grass
894	30	Woods, Good, HSG A
24,730		Weighted Average
6,654		26.91% Pervious Area
18,076		73.09% Impervious Area

Tc (min)	Length (feet)	Slope (ft/ft)	Velocity (ft/sec)	Capacity (cfs)	Description
6.0					Direct Entry,

Subcatchment 3S: Sub 3

Hydrograph

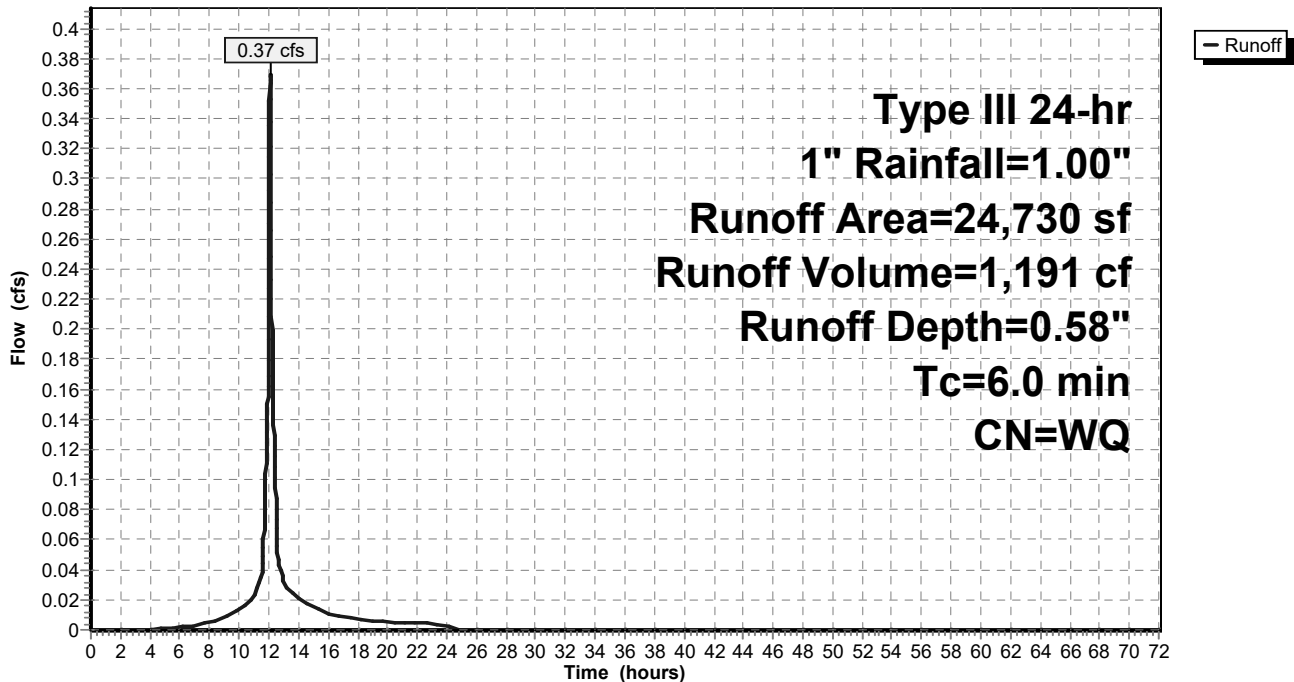

Spofford Isolator Sizing

Prepared by Weston & Sampson

HydroCAD® 10.10-6a s/n 00455 © 2020 HydroCAD Software Solutions LLC

Type III 24-hr 1" Rainfall=1.00"

Printed 11/5/2021

Page 10

Summary for Subcatchment 4S: Sub 4

Runoff = 0.18 cfs @ 12.08 hrs, Volume= 573 cf, Depth= 0.49"
 Routed to Pond 4P : Isolator Rows

Runoff by SCS TR-20 method, UH=SCS, Weighted-Q, Time Span= 0.00-72.00 hrs, dt= 0.01 hrs
 Type III 24-hr 1" Rainfall=1.00"

Area (sf)	CN	Description
8,691	98	Paved parking, HSG A
2,060	30	Woods, Good, HSG A
* 3,200	30	Grass
13,951		Weighted Average
5,260		37.70% Pervious Area
8,691		62.30% Impervious Area

Tc (min)	Length (feet)	Slope (ft/ft)	Velocity (ft/sec)	Capacity (cfs)	Description
6.0					Direct Entry,

Subcatchment 4S: Sub 4

Hydrograph

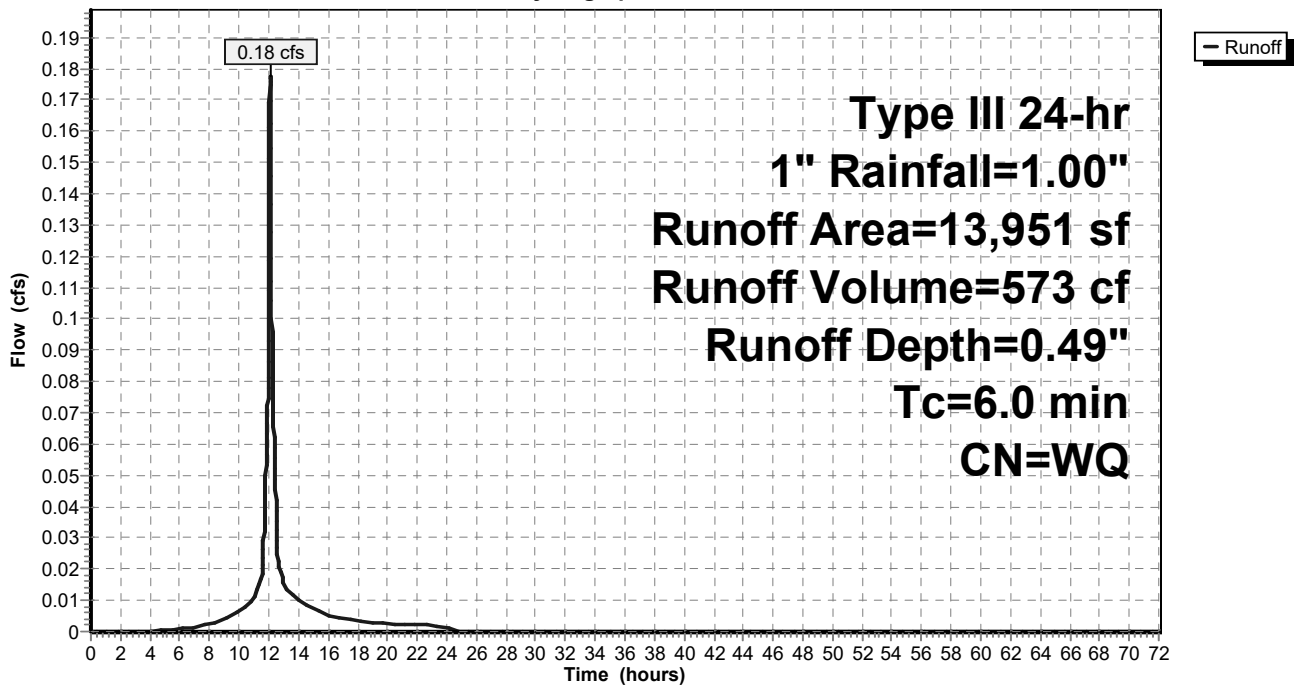

Spofford Isolator Sizing

Prepared by Weston & Sampson

HydroCAD® 10.10-6a s/n 00455 © 2020 HydroCAD Software Solutions LLC

Type III 24-hr 1" Rainfall=1.00"

Printed 11/5/2021

Page 11

Summary for Subcatchment 5S: Sub 5

Runoff = 0.16 cfs @ 12.08 hrs, Volume= 505 cf, Depth= 0.63"
 Routed to Pond 4P : Isolator Rows

Runoff by SCS TR-20 method, UH=SCS, Weighted-Q, Time Span= 0.00-72.00 hrs, dt= 0.01 hrs
 Type III 24-hr 1" Rainfall=1.00"

Area (sf)	CN	Description
7,665	98	Paved parking, HSG A
* 2,034	30	Grass
9,699		Weighted Average
2,034		20.97% Pervious Area
7,665		79.03% Impervious Area

Tc (min)	Length (feet)	Slope (ft/ft)	Velocity (ft/sec)	Capacity (cfs)	Description
6.0					Direct Entry,

Subcatchment 5S: Sub 5

Hydrograph

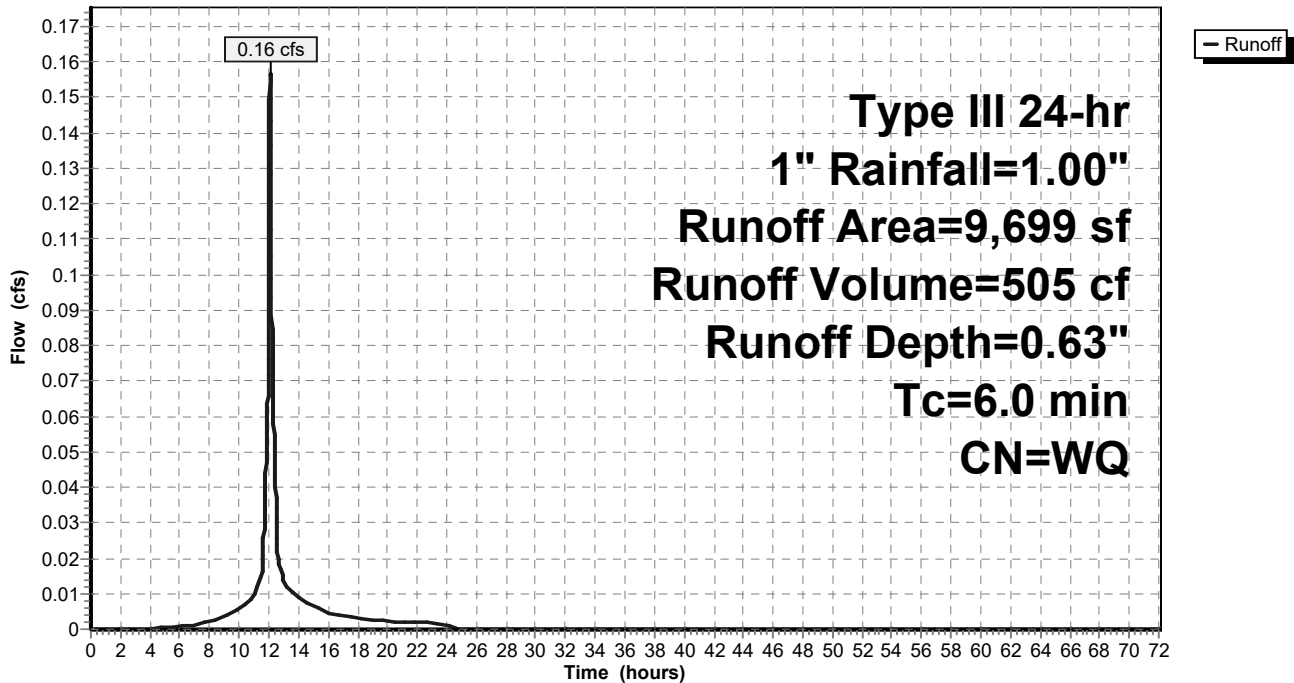

Spofford Isolator Sizing

Prepared by Weston & Sampson

HydroCAD® 10.10-6a s/n 00455 © 2020 HydroCAD Software Solutions LLC

Type III 24-hr 1" Rainfall=1.00"

Printed 11/5/2021

Page 12

Summary for Subcatchment 7S: Sub 7

Runoff = 0.05 cfs @ 12.08 hrs, Volume= 163 cf, Depth= 0.79"
Routed to Pond 4P : Isolator Rows

Runoff by SCS TR-20 method, UH=SCS, Weighted-Q, Time Span= 0.00-72.00 hrs, dt= 0.01 hrs
Type III 24-hr 1" Rainfall=1.00"

Area (sf)	CN	Description
2,469	98	Paved parking, HSG A
2,469		100.00% Impervious Area

Tc (min)	Length (feet)	Slope (ft/ft)	Velocity (ft/sec)	Capacity (cfs)	Description
6.0					Direct Entry,

Subcatchment 7S: Sub 7

Hydrograph

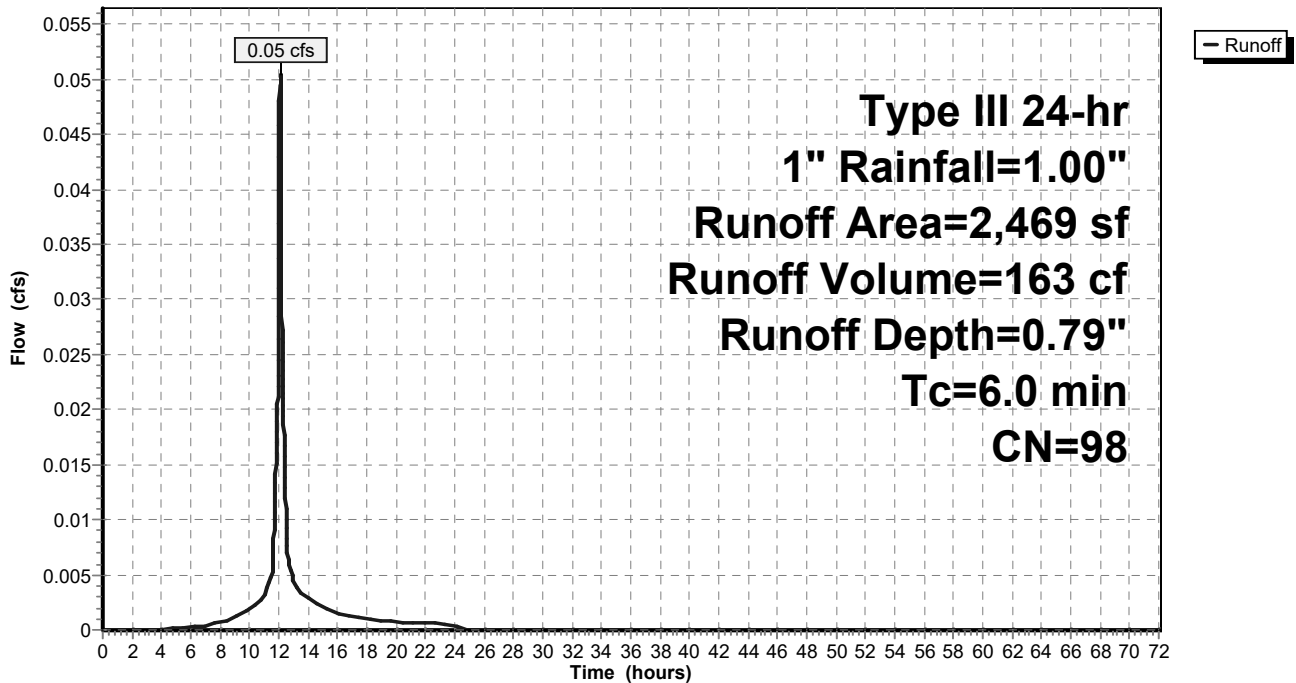

Spofford Isolator Sizing

Prepared by Weston & Sampson

HydroCAD® 10.10-6a s/n 00455 © 2020 HydroCAD Software Solutions LLC

Type III 24-hr 1" Rainfall=1.00"

Printed 11/5/2021

Page 13

Summary for Subcatchment 9S: Sub 9

Runoff = 0.22 cfs @ 12.08 hrs, Volume= 694 cf, Depth= 0.76"
 Routed to Pond 4P : Isolator Rows

Runoff by SCS TR-20 method, UH=SCS, Weighted-Q, Time Span= 0.00-72.00 hrs, dt= 0.01 hrs
 Type III 24-hr 1" Rainfall=1.00"

Area (sf)	CN	Description
10,537	98	Paved parking, HSG A
* 405	30	Grass
10,942		Weighted Average
405		3.70% Pervious Area
10,537		96.30% Impervious Area

Tc (min)	Length (feet)	Slope (ft/ft)	Velocity (ft/sec)	Capacity (cfs)	Description
6.0					Direct Entry,

Subcatchment 9S: Sub 9

Hydrograph

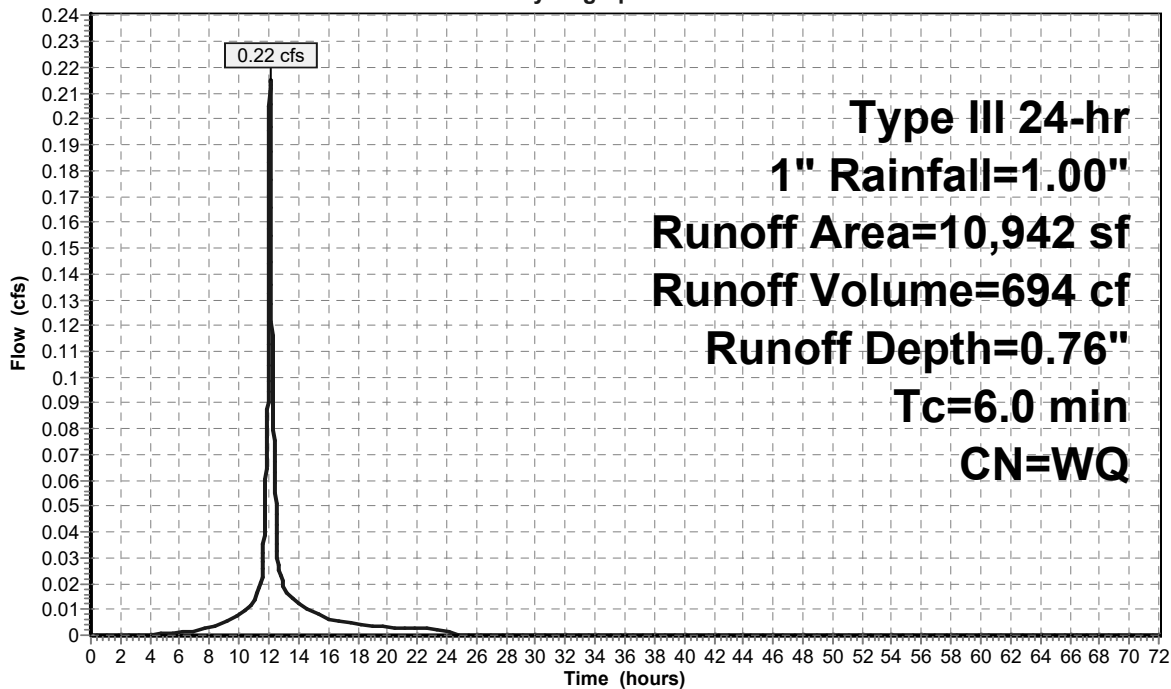

Spofford Isolator Sizing

Prepared by Weston & Sampson

HydroCAD® 10.10-6a s/n 00455 © 2020 HydroCAD Software Solutions LLC

Type III 24-hr 1" Rainfall=1.00"

Printed 11/5/2021

Page 14

Summary for Subcatchment 10S: Sub 10

Runoff = 0.26 cfs @ 12.08 hrs, Volume= 843 cf, Depth= 0.55"
 Routed to Pond 4P : Isolator Rows

Runoff by SCS TR-20 method, UH=SCS, Weighted-Q, Time Span= 0.00-72.00 hrs, dt= 0.01 hrs
 Type III 24-hr 1" Rainfall=1.00"

Area (sf)	CN	Description
12,796	98	Paved parking, HSG A
424	30	Woods, Good, HSG A
* 5,312	30	Grass
18,532		Weighted Average
5,736		30.95% Pervious Area
12,796		69.05% Impervious Area

Tc (min)	Length (feet)	Slope (ft/ft)	Velocity (ft/sec)	Capacity (cfs)	Description
6.0					Direct Entry,

Subcatchment 10S: Sub 10

Hydrograph

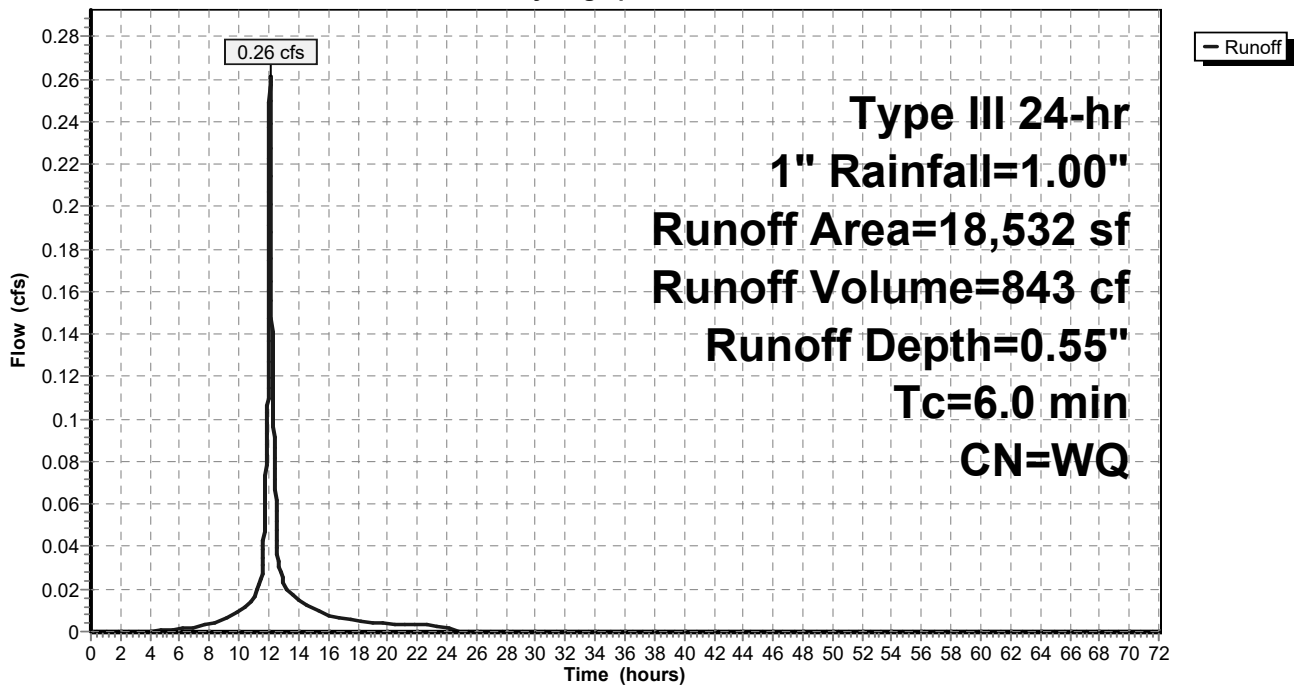

Spofford Isolator Sizing

Prepared by Weston & Sampson

HydroCAD® 10.10-6a s/n 00455 © 2020 HydroCAD Software Solutions LLC

Type III 24-hr 1" Rainfall=1.00"

Printed 11/5/2021

Page 15

Summary for Subcatchment 11S: Sub 11

Runoff = 0.14 cfs @ 12.08 hrs, Volume= 442 cf, Depth= 0.78"
 Routed to Pond 4P : Isolator Rows

Runoff by SCS TR-20 method, UH=SCS, Weighted-Q, Time Span= 0.00-72.00 hrs, dt= 0.01 hrs
 Type III 24-hr 1" Rainfall=1.00"

Area (sf)	CN	Description
6,701	98	Paved parking, HSG A
* 107	30	Grass
6,808		Weighted Average
107		1.57% Pervious Area
6,701		98.43% Impervious Area

Tc (min)	Length (feet)	Slope (ft/ft)	Velocity (ft/sec)	Capacity (cfs)	Description
6.0					Direct Entry,

Subcatchment 11S: Sub 11

Hydrograph

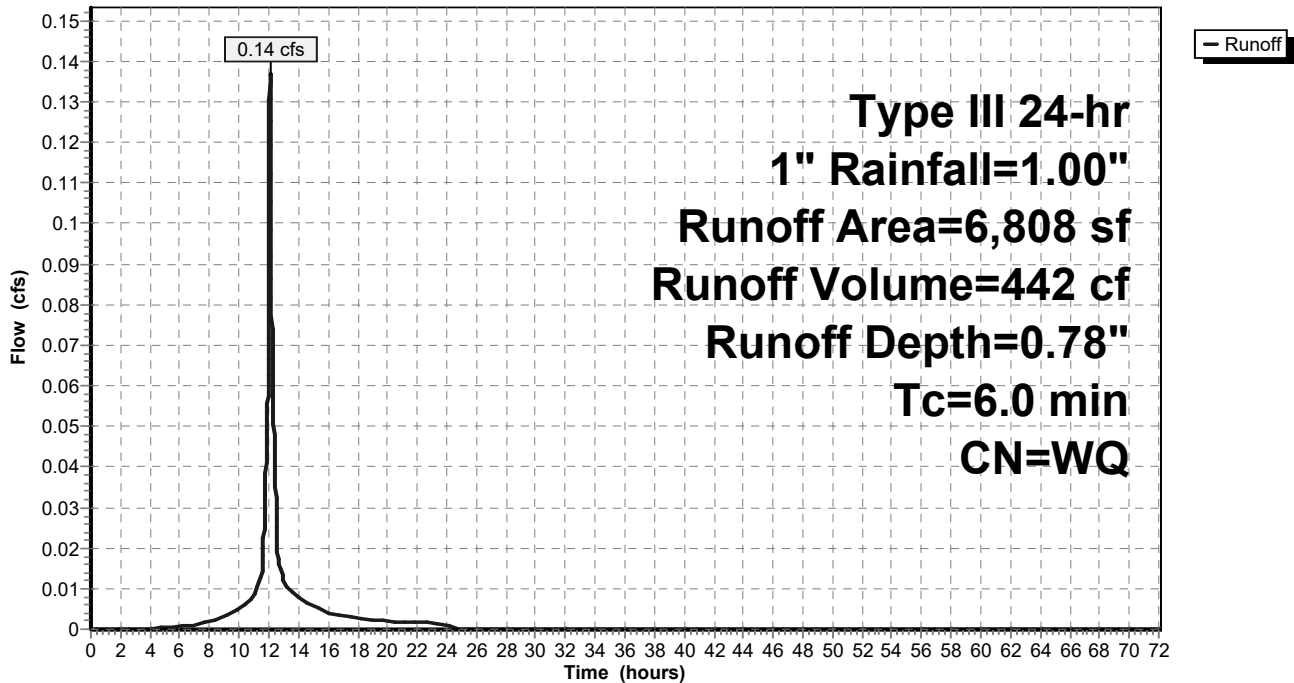

Spofford Isolator Sizing

Prepared by Weston & Sampson

HydroCAD® 10.10-6a s/n 00455 © 2020 HydroCAD Software Solutions LLC

Type III 24-hr 1" Rainfall=1.00"

Printed 11/5/2021

Page 16

Summary for Subcatchment 13S: Sub 13

Runoff = 0.06 cfs @ 12.08 hrs, Volume= 192 cf, Depth= 0.69"
 Routed to Pond 4P : Isolator Rows

Runoff by SCS TR-20 method, UH=SCS, Weighted-Q, Time Span= 0.00-72.00 hrs, dt= 0.01 hrs
 Type III 24-hr 1" Rainfall=1.00"

Area (sf)	CN	Description
2,910	98	Paved parking, HSG A
* 408	30	Grass
3,318		Weighted Average
408		12.30% Pervious Area
2,910		87.70% Impervious Area

Tc (min)	Length (feet)	Slope (ft/ft)	Velocity (ft/sec)	Capacity (cfs)	Description
6.0					Direct Entry,

Subcatchment 13S: Sub 13

Hydrograph

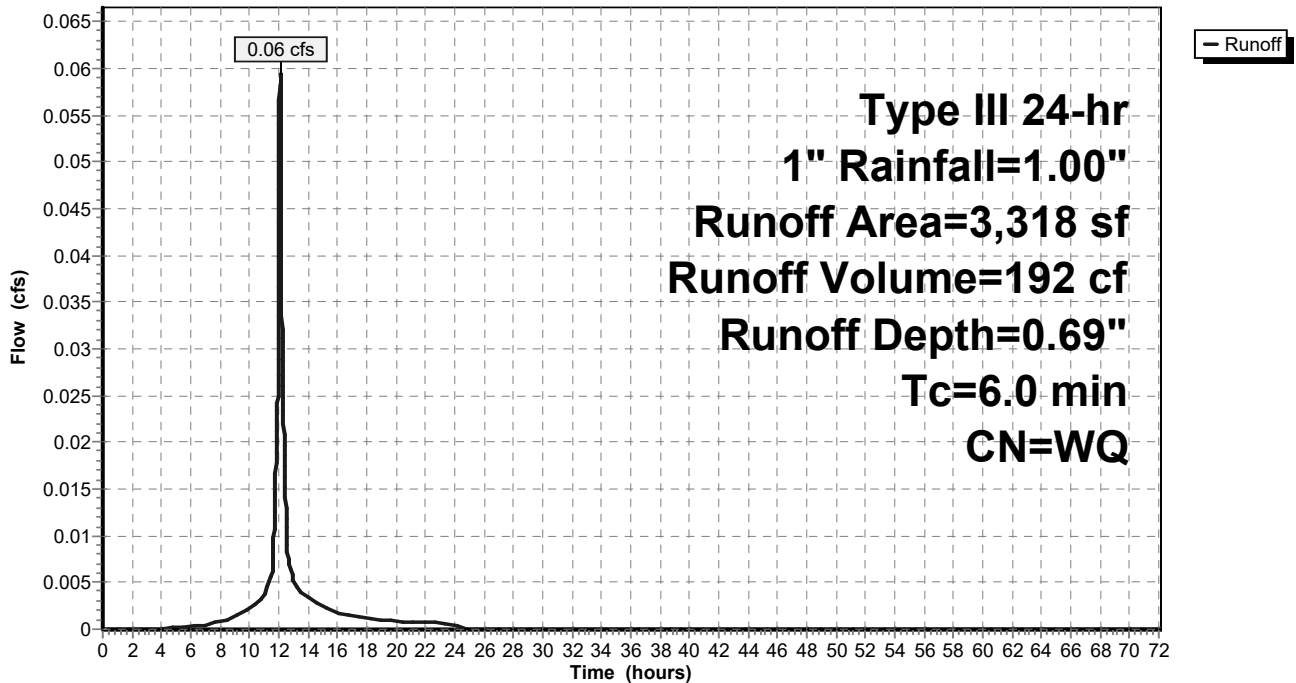

Spofford Isolator Sizing

Prepared by Weston & Sampson

HydroCAD® 10.10-6a s/n 00455 © 2020 HydroCAD Software Solutions LLC

Type III 24-hr 1" Rainfall=1.00"

Printed 11/5/2021

Page 17

Summary for Subcatchment 14S: Sub 14

Runoff = 0.08 cfs @ 12.08 hrs, Volume= 247 cf, Depth= 0.76"
 Routed to Pond 4P : Isolator Rows

Runoff by SCS TR-20 method, UH=SCS, Weighted-Q, Time Span= 0.00-72.00 hrs, dt= 0.01 hrs
 Type III 24-hr 1" Rainfall=1.00"

Area (sf)	CN	Description
3,743	98	Paved parking, HSG A
* 155	30	Grass
3,898		Weighted Average
155		3.98% Pervious Area
3,743		96.02% Impervious Area

Tc (min)	Length (feet)	Slope (ft/ft)	Velocity (ft/sec)	Capacity (cfs)	Description
6.0					Direct Entry,

Subcatchment 14S: Sub 14

Hydrograph

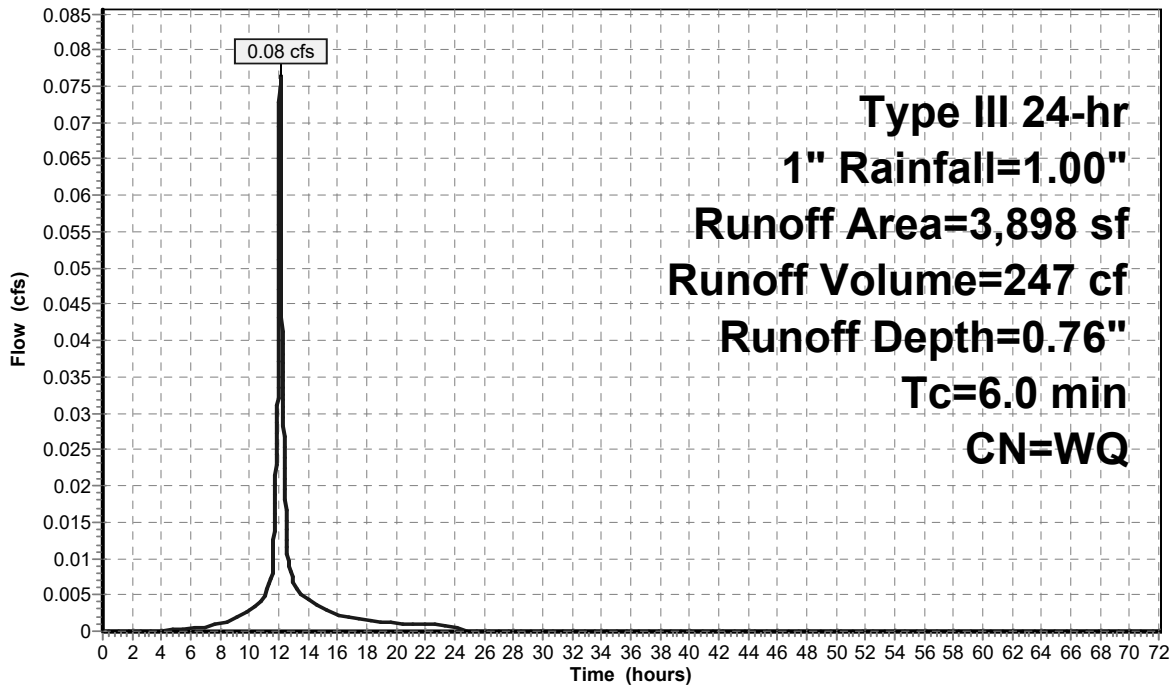

Spofford Isolator Sizing

Prepared by Weston & Sampson

HydroCAD® 10.10-6a s/n 00455 © 2020 HydroCAD Software Solutions LLC

Type III 24-hr 1" Rainfall=1.00"

Printed 11/5/2021

Page 18

Summary for Subcatchment 16S: Sub 16

Runoff = 0.21 cfs @ 12.08 hrs, Volume= 685 cf, Depth= 0.73"
 Routed to Pond 4P : Isolator Rows

Runoff by SCS TR-20 method, UH=SCS, Weighted-Q, Time Span= 0.00-72.00 hrs, dt= 0.01 hrs
 Type III 24-hr 1" Rainfall=1.00"

Area (sf)	CN	Description
10,400	98	Paved parking, HSG A
* 822	30	Grass
11,222		Weighted Average
822		7.32% Pervious Area
10,400		92.68% Impervious Area

Tc (min)	Length (feet)	Slope (ft/ft)	Velocity (ft/sec)	Capacity (cfs)	Description
6.0					Direct Entry,

Subcatchment 16S: Sub 16

Hydrograph

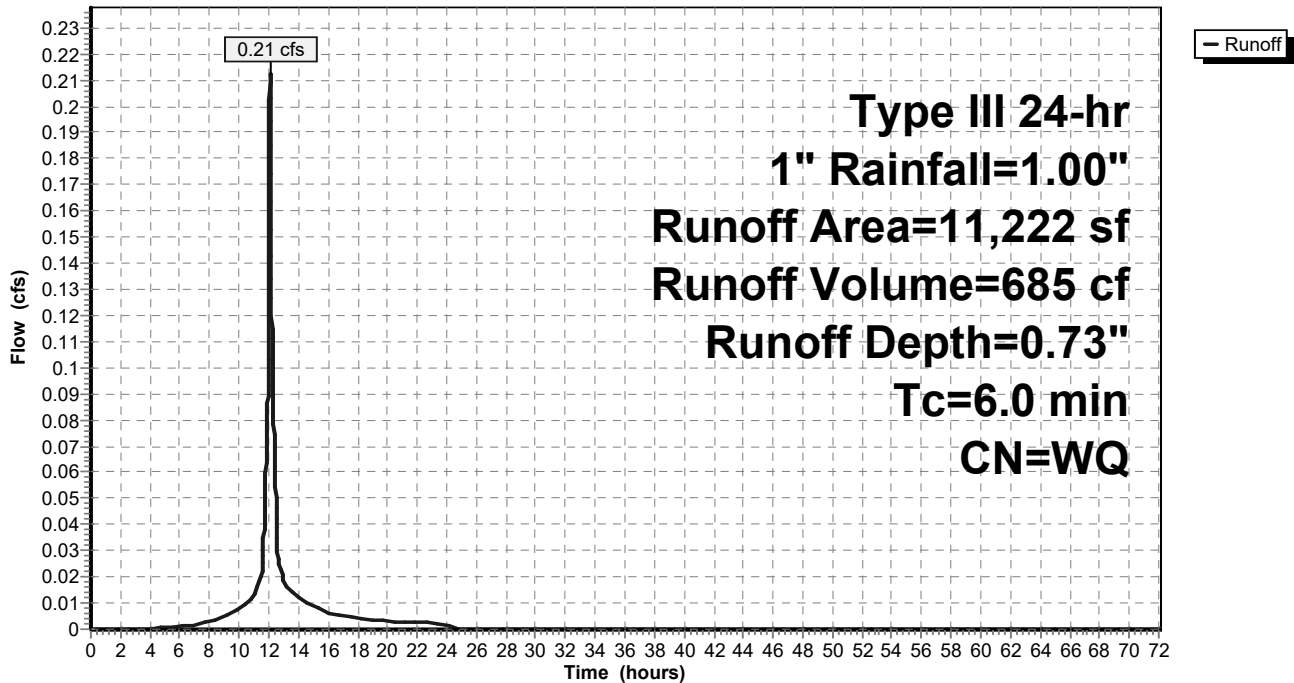

Spofford Isolator Sizing

Prepared by Weston & Sampson

HydroCAD® 10.10-6a s/n 00455 © 2020 HydroCAD Software Solutions LLC

Type III 24-hr 1" Rainfall=1.00"

Printed 11/5/2021

Page 19

Summary for Subcatchment 17S: Sub 17

Runoff = 0.22 cfs @ 12.08 hrs, Volume= 705 cf, Depth= 0.78"
 Routed to Pond 4P : Isolator Rows

Runoff by SCS TR-20 method, UH=SCS, Weighted-Q, Time Span= 0.00-72.00 hrs, dt= 0.01 hrs
 Type III 24-hr 1" Rainfall=1.00"

Area (sf)	CN	Description
155	30	Grass
10,696	98	Paved parking, HSG A
10,851		Weighted Average
155		1.43% Pervious Area
10,696		98.57% Impervious Area

Tc (min)	Length (feet)	Slope (ft/ft)	Velocity (ft/sec)	Capacity (cfs)	Description
6.0					Direct Entry,

Subcatchment 17S: Sub 17

Hydrograph

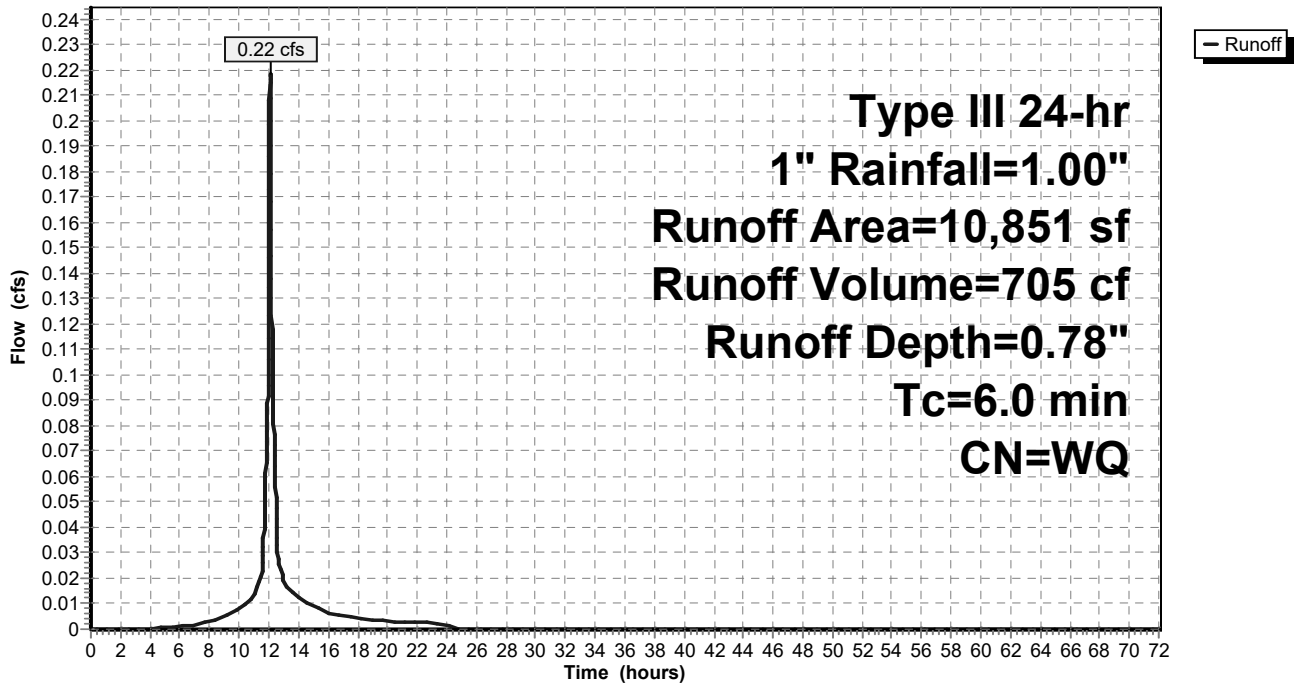

Spofford Isolator Sizing

Prepared by Weston & Sampson

HydroCAD® 10.10-6a s/n 00455 © 2020 HydroCAD Software Solutions LLC

Type III 24-hr 1" Rainfall=1.00"

Printed 11/5/2021

Page 20

Summary for Pond 4P: Isolator Rows

Inflow Area = 187,581 sf, 88.41% Impervious, Inflow Depth = 0.70" for 1" event
 Inflow = 3.39 cfs @ 12.08 hrs, Volume= 10,931 cf
 Outflow = 0.64 cfs @ 12.53 hrs, Volume= 10,932 cf, Atten= 81%, Lag= 26.6 min
 Primary = 0.64 cfs @ 12.53 hrs, Volume= 10,932 cf
 Routed to nonexistent node 4L

Routing by Dyn-Stor-Ind method, Time Span= 0.00-72.00 hrs, dt= 0.01 hrs
 Peak Elev= 130.24' @ 12.53 hrs Surf.Area= 1,003 sf Storage= 3,424 cf

Plug-Flow detention time= (not calculated: outflow precedes inflow)
 Center-of-Mass det. time= 42.7 min (830.6 - 787.9)

Volume	Invert	Avail.Storage	Storage Description
#1	128.26'	3,675 cf	ADS_StormTech SC-740 +Cap x 80 Effective Size= 44.6"W x 30.0"H => 6.45 sf x 7.12'L = 45.9 cf Overall Size= 51.0"W x 30.0"H x 7.56'L with 0.44' Overlap 80 Chambers in 5 Rows

Device	Routing	Invert	Outlet Devices
#1	Primary	127.66'	24.0" Round Culvert L= 92.0' CPP, projecting, no headwall, Ke= 0.900 Inlet / Outlet Invert= 127.66' / 127.15' S= 0.0055 '/' Cc= 0.900 n= 0.013 Corrugated PE, smooth interior, Flow Area= 3.14 sf
#2	Device 4	128.26'	16.00 cfs Exfiltration at all elevations Phase-In= 0.01'
#3	Device 4	128.27'	18.0" Round Culvert L= 48.0' CPP, square edge headwall, Ke= 0.500 Inlet / Outlet Invert= 128.27' / 128.27' S= 0.0000 '/' Cc= 0.900 n= 0.013 Corrugated PE, smooth interior, Flow Area= 1.77 sf
#4	Device 1	127.76'	4.0" Vert. Orifice/Grate C= 0.600 Limited to weir flow at low heads

Primary OutFlow Max=0.64 cfs @ 12.53 hrs HW=130.24' (Free Discharge)

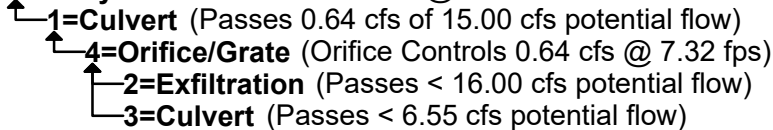

Spofford Isolator Sizing

Prepared by Weston & Sampson

HydroCAD® 10.10-6a s/n 00455 © 2020 HydroCAD Software Solutions LLC

Type III 24-hr 1" Rainfall=1.00"

Printed 11/5/2021

Page 21

Pond 4P: Isolator Rows

Hydrograph

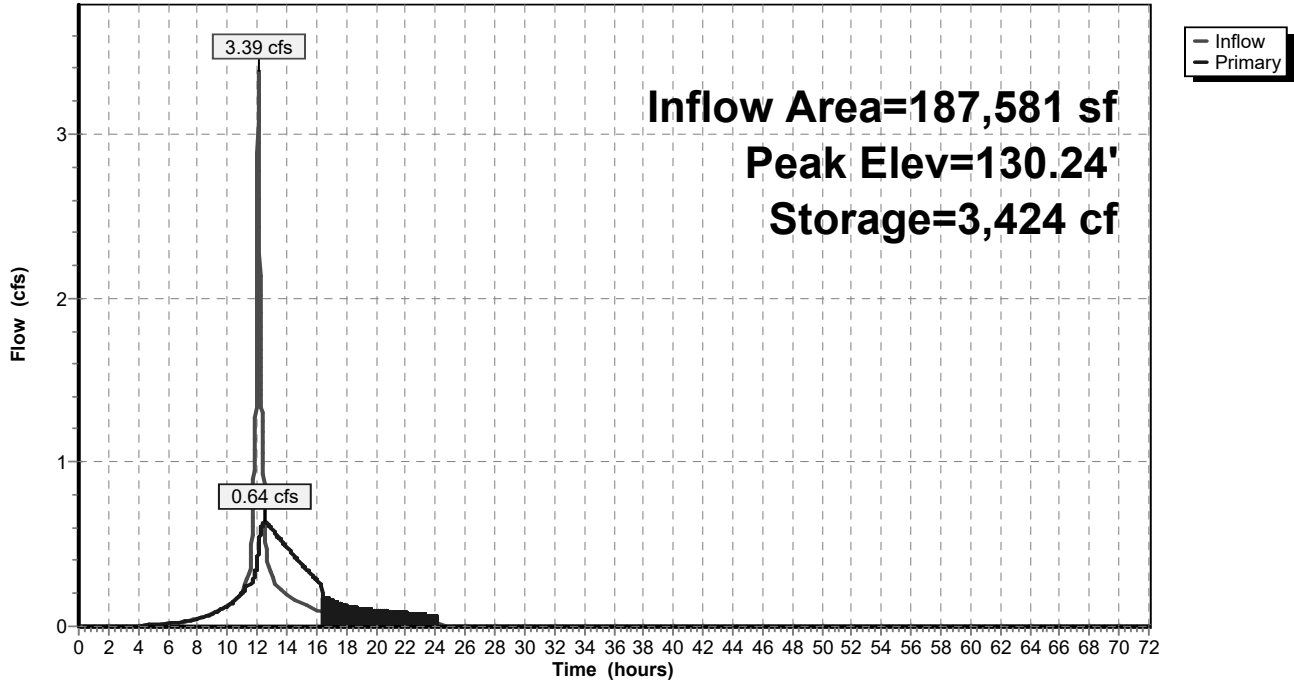

Spofford Isolator Sizing

Prepared by Weston & Sampson

HydroCAD® 10.10-6a s/n 00455 © 2020 HydroCAD Software Solutions LLC

Type III 24-hr 1" Rainfall=1.00"

Printed 11/5/2021

Page 22

Stage-Discharge for Pond 4P: Isolator Rows

Elevation (feet)	Primary (cfs)	Elevation (feet)	Primary (cfs)	Elevation (feet)	Primary (cfs)
128.26	0.00	129.30	0.49	130.34	0.65
128.28	0.25	129.32	0.50	130.36	0.66
128.30	0.26	129.34	0.50	130.38	0.66
128.32	0.26	129.36	0.50	130.40	0.66
128.34	0.27	129.38	0.51	130.42	0.66
128.36	0.28	129.40	0.51	130.44	0.67
128.38	0.28	129.42	0.51	130.46	0.67
128.40	0.29	129.44	0.52	130.48	0.67
128.42	0.30	129.46	0.52	130.50	0.67
128.44	0.30	129.48	0.52	130.52	0.68
128.46	0.31	129.50	0.53	130.54	0.68
128.48	0.31	129.52	0.53	130.56	0.68
128.50	0.32	129.54	0.53	130.58	0.68
128.52	0.32	129.56	0.54	130.60	0.69
128.54	0.33	129.58	0.54	130.62	0.69
128.56	0.33	129.60	0.54	130.64	0.69
128.58	0.34	129.62	0.55	130.66	0.69
128.60	0.34	129.64	0.55	130.68	0.70
128.62	0.35	129.66	0.55	130.70	0.70
128.64	0.35	129.68	0.56	130.72	0.70
128.66	0.36	129.70	0.56	130.74	0.70
128.68	0.36	129.72	0.56	130.76	0.71
128.70	0.37	129.74	0.57		
128.72	0.37	129.76	0.57		
128.74	0.38	129.78	0.57		
128.76	0.38	129.80	0.58		
128.78	0.39	129.82	0.58		
128.80	0.39	129.84	0.58		
128.82	0.40	129.86	0.58		
128.84	0.40	129.88	0.59		
128.86	0.41	129.90	0.59		
128.88	0.41	129.92	0.59		
128.90	0.41	129.94	0.60		
128.92	0.42	129.96	0.60		
128.94	0.42	129.98	0.60		
128.96	0.43	130.00	0.61		
128.98	0.43	130.02	0.61		
129.00	0.44	130.04	0.61		
129.02	0.44	130.06	0.61		
129.04	0.44	130.08	0.62		
129.06	0.45	130.10	0.62		
129.08	0.45	130.12	0.62		
129.10	0.46	130.14	0.63		
129.12	0.46	130.16	0.63		
129.14	0.46	130.18	0.63		
129.16	0.47	130.20	0.63		
129.18	0.47	130.22	0.64		
129.20	0.47	130.24	0.64		
129.22	0.48	130.26	0.64		
129.24	0.48	130.28	0.64		
129.26	0.49	130.30	0.65		
129.28	0.49	130.32	0.65		

Spofford Isolator Sizing

Prepared by Weston & Sampson

HydroCAD® 10.10-6a s/n 00455 © 2020 HydroCAD Software Solutions LLC

Type III 24-hr 1" Rainfall=1.00"

Printed 11/5/2021

Page 23

Stage-Area-Storage for Pond 4P: Isolator Rows

Elevation (feet)	Storage (cubic-feet)	Elevation (feet)	Storage (cubic-feet)	Elevation (feet)	Storage (cubic-feet)
128.26	0	129.30	2,063	130.34	3,518
128.28	42	129.32	2,099	130.36	3,535
128.30	85	129.34	2,134	130.38	3,551
128.32	127	129.36	2,169	130.40	3,566
128.34	169	129.38	2,204	130.42	3,580
128.36	212	129.40	2,239	130.44	3,593
128.38	254	129.42	2,273	130.46	3,605
128.40	296	129.44	2,307	130.48	3,616
128.42	338	129.46	2,341	130.50	3,626
128.44	380	129.48	2,374	130.52	3,635
128.46	422	129.50	2,408	130.54	3,642
128.48	464	129.52	2,441	130.56	3,649
128.50	506	129.54	2,474	130.58	3,654
128.52	547	129.56	2,506	130.60	3,659
128.54	589	129.58	2,539	130.62	3,663
128.56	630	129.60	2,571	130.64	3,666
128.58	671	129.62	2,603	130.66	3,669
128.60	713	129.64	2,635	130.68	3,671
128.62	754	129.66	2,666	130.70	3,673
128.64	795	129.68	2,697	130.72	3,674
128.66	835	129.70	2,728	130.74	3,675
128.68	876	129.72	2,758	130.76	3,675
128.70	917	129.74	2,788		
128.72	957	129.76	2,818		
128.74	997	129.78	2,848		
128.76	1,038	129.80	2,877		
128.78	1,078	129.82	2,906		
128.80	1,118	129.84	2,935		
128.82	1,157	129.86	2,964		
128.84	1,197	129.88	2,992		
128.86	1,236	129.90	3,019		
128.88	1,276	129.92	3,047		
128.90	1,315	129.94	3,073		
128.92	1,354	129.96	3,100		
128.94	1,393	129.98	3,126		
128.96	1,431	130.00	3,151		
128.98	1,470	130.02	3,177		
129.00	1,508	130.04	3,201		
129.02	1,547	130.06	3,226		
129.04	1,585	130.08	3,250		
129.06	1,623	130.10	3,273		
129.08	1,660	130.12	3,296		
129.10	1,698	130.14	3,319		
129.12	1,735	130.16	3,341		
129.14	1,772	130.18	3,363		
129.16	1,809	130.20	3,385		
129.18	1,846	130.22	3,405		
129.20	1,883	130.24	3,426		
129.22	1,919	130.26	3,445		
129.24	1,956	130.28	3,465		
129.26	1,992	130.30	3,483		
129.28	2,028	130.32	3,501		

Spofford Pond School
Diversion Weir Calculation

Minimum Baffle Elevation (See Isolator Row Sizing Calculations)

During 1" storm, peak elevation = 130.24

This signifies that the baffle would need to be at least 130.24 to direct 1" of flow to the isolator rows.

Maximum Baffle Elevation

The following equation for a sharp crested weir has been provided by the chamber manufacturer:

$$Q = C \sqrt{2g} LH^{3/2}$$

$$C = 0.40 + 0.05 \frac{H}{P}$$

Q = flow rate (cfs)

C = discharge coefficient

L = length of weir (ft)

H = approach head on the crest (ft)

P = height of crest above channel bottom (ft)

g = gravity (32.2 ft/s²)

Q = 41.40 cfs (flow to Stormtech System during 100-yr storm)

P = 2.98 ft

g = 32.2 ft/s²

L = 4 ft

H = ?

$$41.40 = [0.40 + 0.05 (H / 2.98)] [\sqrt{2 * 32.2}] [4] [H^{3/2}]$$

$$41.40 = 32.09 (0.016 H + 0.4) H^{3/2}$$

$$41.40 = (0.53 H + 12.83) H^{3/2}$$

$$41.40 = 0.53 H^{5/2} + 12.83 H^{3/2}$$

$$\sqrt{H} = 1.43$$

$$H = 2.04 \text{ ft}$$

2.04 ft + 131.0 ft (proposed weir elevation within OCS-2) = 133.04 (Elevation required within OCS-2 to pass the peak flow)

Elevation of ceiling of OCS-2 = 134.10

The elevation within OCS-2 required to pass the peak flow is less than the elevation of the ceiling of OCS-2. This signifies that the top of the weir is at an acceptable elevation. Based on the calculated "H" above, the maximum elevation for the weir within OCS-2 would be 132.06.

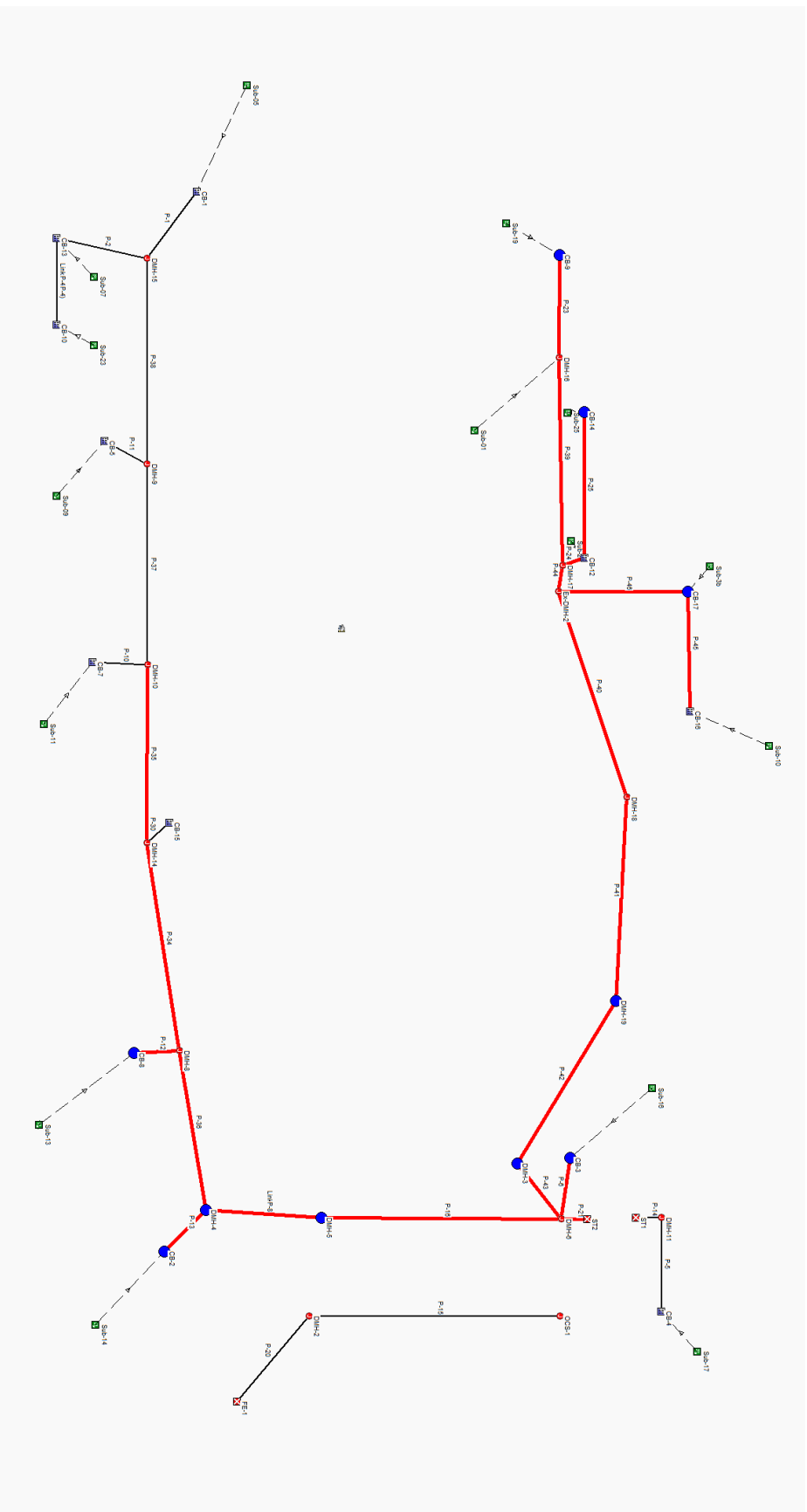

Project Description

File Name Spofford Pond.SPF

Project Options

Flow Units CFS
 Elevation Type Elevation
 Hydrology Method SCS TR-20
 Time of Concentration (TOC) Method Kirpich
 Link Routing Method Hydrodynamic
 Enable Overflow Ponding at Nodes YES
 Skip Steady State Analysis Time Periods NO

Analysis Options

Start Analysis On Nov 05, 2021 00:00:00
 End Analysis On Nov 06, 2021 00:00:00
 Start Reporting On Nov 05, 2021 00:00:00
 Antecedent Dry Days 0 days
 Runoff (Dry Weather) Time Step 0 01:00:00 days hh:mm:ss
 Runoff (Wet Weather) Time Step 0 00:05:00 days hh:mm:ss
 Reporting Time Step 0 00:05:00 days hh:mm:ss
 Routing Time Step 30 seconds

Number of Elements

	Qty
Rain Gages	1
Subbasins.....	15
Nodes.....	35
<i>Junctions</i>	17
<i>Outfalls</i>	3
<i>Flow Diversions</i>	0
<i>Inlets</i>	15
<i>Storage Nodes</i>	0
Links.....	34
<i>Channels</i>	0
<i>Pipes</i>	34
<i>Pumps</i>	0
<i>Orifices</i>	0
<i>Weirs</i>	0
<i>Outlets</i>	0
Pollutants	0
Land Uses	0

Rainfall Details

SN	Rain Gage ID	Data Source	Data Source ID	Rainfall Type	Rain Units	State	County	Return Period (years)	Rainfall Depth (inches)	Rainfall Distribution
1	Rain Gage-01	Time Series	10-YR	Cumulative	inches	None	None	10	5.12	SCS Type III 24-hr

Subbasin Summary

SN	Subbasin ID	Area (ac)	Weighted Curve Number	Average Slope (%)	Flow Length (ft)	Total Rainfall (in)	Total Runoff (in)	Total Runoff Volume (ac-in)	Peak Runoff (cfs)	Time of Concentration (days hh:mm:ss)
1	Sub-01	1.63	98.00	0.5000	500.00	5.12	4.88	7.96	6.91	0 00:07:10
2	Sub-05	0.52	82.55	1.6000	214.00	5.12	3.24	1.68	1.71	0 00:06:00
3	Sub-07	0.02	98.00	2.2000	59.00	5.12	4.72	0.10	0.08	0 00:06:00
4	Sub-09	0.21	95.61	0.5000	500.00	5.12	4.61	0.99	0.91	0 00:06:00
5	Sub-10	0.17	93.26	1.4400	138.00	5.12	4.34	0.76	0.71	0 00:06:00
6	Sub-11	0.10	96.56	0.5000	500.00	5.12	4.71	0.46	0.41	0 00:06:00
7	Sub-13	0.08	90.00	0.5000	500.00	5.12	3.98	0.30	0.29	0 00:07:10
8	Sub-14	0.09	95.00	0.5000	500.00	5.12	4.53	0.41	0.37	0 00:07:10
9	Sub-16	0.16	87.87	1.2400	253.00	5.12	3.77	0.59	0.60	0 00:06:00
10	Sub-17	0.25	97.00	0.5000	500.00	5.12	4.77	1.19	1.05	0 00:07:10
11	Sub-19	0.09	61.80	0.0484	65.00	5.12	1.50	0.14	0.13	0 00:06:00
12	Sub-23	0.06	96.30	2.8000	63.00	5.12	4.67	0.28	0.24	0 00:06:00
13	Sub-25	0.07	80.12	3.6000	90.00	5.12	3.00	0.20	0.20	0 00:06:00
14	Sub-26	0.03	98.00	0.0090	59.00	5.12	4.85	0.15	0.14	0 00:06:30
15	Sub-3b	0.51	86.17	1.5000	160.00	5.12	3.60	1.84	1.84	0 00:06:00

Node Summary

SN	Element ID	Element Type	Invert Elevation	Ground/Rim (Max) Elevation	Initial Water Elevation	Surcharge Elevation	Ponded Area	Peak Inflow	Max HGL Elevation Attained	Max Surcharge Depth Attained	Min Freeboard Attained	Time of Peak Flooding Occurrence	Total Flooded Volume	Total Time Flooded
			(ft)	(ft)	(ft)	(ft)	(ft ²)	(cfs)	(ft)	(ft)	(ft)	(days hh:mm)	(ac-in)	(min)
1	DMH-10	Junction	130.91	137.43	133.50	137.42	10.00	19.09	133.51	0.00	3.92	0 00:00	0.00	0.00
2	DMH-11	Junction	129.35	133.36	129.35	133.36	10.00	1.02	129.55	0.00	3.81	0 00:00	0.00	0.00
3	DMH-14	Junction	130.38	137.77	130.54	137.77	10.00	43.57	134.16	0.00	3.61	0 00:00	0.00	0.00
4	DMH-15	Junction	132.42	136.95	133.35	136.95	10.00	1.98	133.35	0.00	3.60	0 00:00	0.00	0.00
5	DMH-16	Junction	132.80	138.34	134.00	138.34	10.00	6.82	138.38	0.04	0.00	0 12:10	0.00	3.00
6	DMH-17	Junction	132.20	138.06	132.70	138.06	0.00	5.45	137.02	0.00	1.04	0 00:00	0.00	0.00
7	DMH-18	Junction	131.16	137.63	0.00	137.63	0.00	7.12	134.88	0.00	2.75	0 00:00	0.00	0.00
8	DMH-19	Junction	130.30	136.60	0.00	136.60	0.00	18.21	136.60	0.00	0.00	0 02:43	0.01	0.00
9	DMH-2	Junction	128.00	134.12	128.00	134.12	10.00	0.00	128.00	0.00	6.12	0 00:00	0.00	0.00
10	DMH-3	Junction	128.46	135.54	0.00	135.54	0.00	85.68	135.54	0.00	0.00	0 23:05	0.64	1.00
11	DMH-4	Junction	128.93	136.00	131.90	136.00	10.00	220.50	145.99	9.99	0.00	0 00:24	11.71	15.00
12	DMH-5	Junction	128.70	135.20	128.70	135.20	10.00	180.47	140.89	5.69	0.00	0 03:19	3.23	8.00
13	DMH-6	Junction	131.00	134.90	131.00	134.90	10.00	72.16	134.90	0.00	0.00	0 00:00	0.00	0.00
14	DMH-8	Junction	129.45	137.46	132.68	137.46	10.00	90.20	137.46	0.00	0.00	0 00:00	0.00	0.00
15	DMH-9	Junction	131.64	136.95	132.62	137.17	10.00	8.19	132.96	0.00	3.99	0 00:00	0.00	0.00
16	Ex-DMH-2	Junction	132.04	138.10	132.50	138.10	10.00	7.14	136.23	0.00	1.87	0 00:00	0.00	0.00
17	OCS-1	Junction	130.45	134.27	130.45	134.27	10.00	0.00	130.45	0.00	3.82	0 00:00	0.00	0.00
18	FE-1	Outfall	127.00					0.00	127.00					
19	ST1	Outfall	128.26					1.02	128.26					
20	ST2	Outfall	128.26					1392.37	128.26					

Link Summary

SN Element ID	Element Type	From (Inlet) Node	To (Outlet) Node	Length (ft)	Inlet Invert Elevation (ft)	Outlet Invert Elevation (ft)	Average Slope (%)	Diameter or Height (in)	Manning's Roughness	Peak Flow (cfs)	Design Flow Capacity (cfs)	Peak Flow/Design Flow Ratio	Peak Flow Velocity (ft/sec)	Peak Flow Depth (ft)	Peak Flow Depth/Total Depth Ratio	Total Time Reported (min)	Surcharged Condition
1 Link-47	Pipe	DMH-4	DMH-5	60.55	128.93	128.63	0.5000	24.000	0.0130	104.15	13.94	7.47	42.96	2.00	1.00	1267.00	SURCHARGED
2 Link-48(P-4)	Pipe	CB-10	CB-13	39.48	132.92	132.72	0.5100	12.000	0.0130	1.01	2.54	0.40	2.18	0.90	0.90	0.00	Calculated
3 P-1	Pipe	CB-1	DMH-15	36.03	133.47	133.35	0.3300	12.000	0.0130	1.67	2.30	0.72	3.16	0.63	0.64	0.00	Calculated
4 P-10	Pipe	CB-7	DMH-10	12.78	133.56	133.50	0.4700	12.000	0.0130	0.40	2.44	0.16	2.11	0.29	0.29	0.00	Calculated
5 P-11	Pipe	CB-5	DMH-9	26.24	132.75	132.62	0.5000	12.000	0.0130	0.89	3.26	0.27	3.17	0.38	0.39	0.00	Calculated
6 P-12	Pipe	CB-8	DMH-8	13.07	133.96	133.89	0.5400	12.000	0.0130	60.38	2.61	23.16	50.00	0.90	1.00	3.00	SURCHARGED
7 P-13	Pipe	CB-2	DMH-4	9.55	133.00	132.90	1.0500	12.000	0.0130	47.14	3.65	12.93	50.00	0.96	1.00	29.00	SURCHARGED
8 P-14	Pipe	ST1	DMH-11	6.19	128.27	128.27	0.0000	24.000	0.0130	1.02	94.59	0.01	7.69	0.17	0.09	0.00	Calculated
9 P-15	Pipe	OCS-1	DMH-2	93.60	127.66	127.15	0.5400	24.000	0.0130	0.00	36.60	0.00	0.00	0.00	0.00	0.00	Calculated
10 P-16	Pipe	DMH-5	DMH-6	126.08	128.53	128.35	0.1400	24.000	0.0130	61.91	30.55	2.03	27.22	1.73	1.00	2.00	SURCHARGED
11 P-2	Pipe	CB-13	DMH-15	19.65	133.45	133.35	0.5100	12.000	0.0130	0.32	2.54	0.13	6.72	0.25	0.25	0.00	Calculated
12 P-20	Pipe	DMH-2	FE-1	34.45	127.10	127.00	0.2900	24.000	0.0130	0.00	38.54	0.00	0.00	0.00	0.00	0.00	Calculated
13 P-21	Pipe	DMH-6	ST2	3.92	128.27	128.27	0.0000	24.000	0.0130	1392.37	188.79	7.38	50.00	0.95	1.00	0.00	> CAPACITY
14 P-23	Pipe	CB-9	DMH-16	34.86	133.07	132.90	0.4900	12.000	0.0130	2.48	2.49	1.00	3.15	1.00	1.00	33.00	SURCHARGED
15 P-24	Pipe	CB-12	DMH-17	6.76	132.34	132.30	0.5900	12.000	0.0150	0.77	2.38	0.32	1.68	1.00	1.00	33.00	SURCHARGED
16 P-25	Pipe	CB-14	CB-12	67.17	132.78	132.44	0.5100	12.000	0.0130	0.91	2.53	0.36	1.16	1.00	1.00	25.00	SURCHARGED
17 P-30	Pipe	CB-15	DMH-14	8.44	134.40	134.35	0.5900	12.000	0.0130	0.00	2.74	0.00	0.00	0.00	0.00	0.00	Calculated
18 P-34	Pipe	DMH-14	DMH-8	165.96	130.38	129.55	0.5000	24.000	0.0130	43.57	16.00	2.72	18.63	2.00	1.00	9.00	SURCHARGED
19 P-35	Pipe	DMH-10	DMH-14	86.67	130.91	130.48	0.5000	24.000	0.0130	19.09	15.93	1.20	6.75	1.83	1.00	1.00	SURCHARGED
20 P-36	Pipe	DMH-8	DMH-4	83.65	129.45	129.03	0.5000	24.000	0.0130	72.44	16.03	4.52	23.23	2.00	1.00	172.00	SURCHARGED
21 P-37	Pipe	DMH-9	DMH-10	126.05	131.64	131.01	0.5000	24.000	0.0130	8.15	15.99	0.51	3.64	1.24	0.77	0.00	Calculated
22 P-38	Pipe	DMH-15	DMH-9	134.96	132.42	131.74	0.5000	24.000	0.0130	2.92	16.06	0.18	3.30	0.49	0.46	0.00	Calculated
23 P-39	Pipe	DMH-16	DMH-17	100.55	132.80	132.30	0.5000	12.000	0.0130	5.09	2.51	2.03	6.48	1.00	1.00	34.00	SURCHARGED
24 P-4	Pipe	CB-10	CB-13	39.48	133.73	133.55	0.4600	12.000	0.0130	0.52	2.41	0.22	6.20	0.09	0.16	0.00	Calculated
25 P-40	Pipe	Ex-DMH-2	DMH-18	155.37	132.04	131.26	0.5000	18.000	0.0150	7.12	6.45	1.10	4.03	1.50	1.00	24.00	SURCHARGED
26 P-41	Pipe	DMH-18	DMH-19	153.22	131.16	130.40	0.5000	18.000	0.0150	7.12	6.41	1.11	5.01	1.50	1.00	32.00	SURCHARGED
27 P-42	Pipe	DMH-19	DMH-3	90.24	130.30	128.56	1.9300	18.000	0.0150	18.21	12.64	1.44	10.31	1.50	1.00	57.00	SURCHARGED
28 P-43	Pipe	DMH-3	DMH-6	19.19	128.46	128.36	0.5200	18.000	0.0150	85.68	33.12	2.59	48.48	1.46	1.00	5.00	SURCHARGED
29 P-44	Pipe	DMH-17	Ex-DMH-2	10.22	132.20	132.14	0.5900	12.000	0.0130	5.35	2.73	1.96	6.81	1.00	1.00	30.00	SURCHARGED
30 P-45	Pipe	CB-16	CB-17	59.01	133.00	132.70	0.5100	18.000	0.0130	2.07	7.49	0.28	1.63	1.50	1.00	16.00	SURCHARGED
31 P-46	Pipe	CB-17	Ex-DMH-2	92.40	132.60	132.14	0.5000	18.000	0.0130	2.62	7.41	0.35	1.54	1.50	1.00	19.00	SURCHARGED
32 P-5	Pipe	CB-4	DMH-11	101.87	129.71	129.20	0.5000	12.000	0.0130	1.02	2.12	0.48	3.97	0.35	0.36	0.00	Calculated
33 P-6	Pipe	CB-3	DMH-6	20.36	132.00	131.89	0.5400	12.000	0.0130	18.70	2.62	7.14	47.37	0.87	1.00	5.00	SURCHARGED
34 P-8	Pipe	DMH-4	DMH-5	60.55	128.70	128.53	0.2800	24.000	0.0130	104.15	13.94	7.47	42.96	2.00	1.00	1267.00	SURCHARGED

Inlet Summary

SN Element ID	Inlet Manufacturer	Manufacturer Part Number	Inlet Location	Number of Inlets	Catchbasin Invert Elevation (ft)	Max (Rim) Elevation (ft)	Initial Water Elevation (ft)	Ponded Area (ft²)	Peak Flow (cfs)	Peak Flow Intercepted (cfs)	Peak Flow Bypassing Inlet (cfs)	Peak Flow during Peak (cfs)	Inlet Efficiency (%)	Allowable Spread (ft)	Max Gutter Spread during Peak (ft)	Max Gutter Water Elev. during Peak (ft)
1 CB-1	FHWA HEC-22 GENERIC	N/A	On Sag	1	133.50	135.47	133.50	200.00	1.68	N/A	N/A	N/A	N/A	7.00	9.07	135.90
2 CB-10	FHWA HEC-22 GENERIC	N/A	On Sag	1	132.92	136.73	0.00	10.00	0.24	N/A	N/A	N/A	N/A	7.00	1.49	136.82
3 CB-12	FHWA HEC-22 GENERIC	N/A	On Sag	1	132.34	137.96	132.58	200.00	0.14	N/A	N/A	N/A	N/A	7.00	0.83	138.01
4 CB-13	FHWA HEC-22 GENERIC	N/A	On Sag	1	132.62	136.30	133.52	200.00	0.08	N/A	N/A	N/A	N/A	7.00	0.51	136.33
5 CB-14	FHWA HEC-22 GENERIC	N/A	On Sag	1	132.78	137.97	0.00	10.00	0.19	N/A	N/A	N/A	N/A	7.00	1.19	138.04
6 CB-15	FHWA HEC-22 GENERIC	N/A	On Sag	1	0.00	137.40	0.00	10.00	0.00	N/A	N/A	N/A	N/A	7.00	0.00	137.40
7 CB-16	FHWA HEC-22 GENERIC	N/A	On Sag	1	133.00	136.72	132.45	200.00	0.70	N/A	N/A	N/A	N/A	7.00	4.33	136.97
8 CB-17	FHWA HEC-22 GENERIC	N/A	On Sag	1	132.60	136.03	131.82	200.00	1.82	N/A	N/A	N/A	N/A	7.00	9.66	136.47
9 CB-2	FHWA HEC-22 GENERIC	N/A	On Sag	1	132.00	136.00	132.00	200.00	0.36	N/A	N/A	N/A	N/A	7.00	2.25	136.13
10 CB-3	FHWA HEC-22 GENERIC	N/A	On Sag	1	131.11	135.36	131.11	200.00	0.59	N/A	N/A	N/A	N/A	7.00	3.63	135.57
11 CB-4	FHWA HEC-22 GENERIC	N/A	On Sag	1	129.71	132.97	129.71	200.00	1.04	N/A	N/A	N/A	N/A	7.00	6.32	133.34
12 CB-5	FHWA HEC-22 GENERIC	N/A	On Sag	1	132.84	136.84	132.84	200.00	0.91	N/A	N/A	N/A	N/A	7.00	5.61	137.17
13 CB-7	FHWA HEC-22 GENERIC	N/A	On Sag	1	133.56	137.23	133.56	200.00	0.40	N/A	N/A	N/A	N/A	7.00	2.50	137.38
14 CB-8	FHWA HEC-22 GENERIC	N/A	On Sag	1	132.75	136.96	132.75	200.00	0.29	N/A	N/A	N/A	N/A	7.00	1.78	137.06
15 CB-9	FHWA HEC-22 GENERIC	N/A	On Sag	1	133.07	138.05	132.80	200.00	0.13	N/A	N/A	N/A	N/A	7.00	0.77	138.09

Subbasin Hydrology

Subbasin : Sub-01

Input Data

Area (ac) 1.63
 Weighted Curve Number 98.00
 Average Slope (%) 0.5000
 Flow Length (ft) 500.00
 Rain Gage ID Rain Gage-01

Composite Curve Number

Soil/Surface Description	Area (acres)	Soil Group	Curve Number
-	5.00	-	98.00
Composite Area & Weighted CN	5.00		98.00

Time of Concentration

TOC Method : Kirpich

Sheet Flow Equation :

$$T_c = (0.0078 * ((L_f^{0.77}) * (S_f^{-0.385})))$$

Where :

T_c = Time of Concentration (min)
 L_f = Flow Length (ft)
 S_f = Slope (ft/ft)

Flow Length (ft) 500.00
 Slope (%) 0.5
 Computed TOC (min) 7.18

Subbasin Runoff Results

Total Rainfall (in) 5.12
 Total Runoff (in) 4.88
 Peak Runoff (cfs) 6.91
 Weighted Curve Number 98.00
 Time of Concentration (days hh:mm:ss) 0 00:07:11

Subbasin : Sub-01

Rainfall Intensity Graph

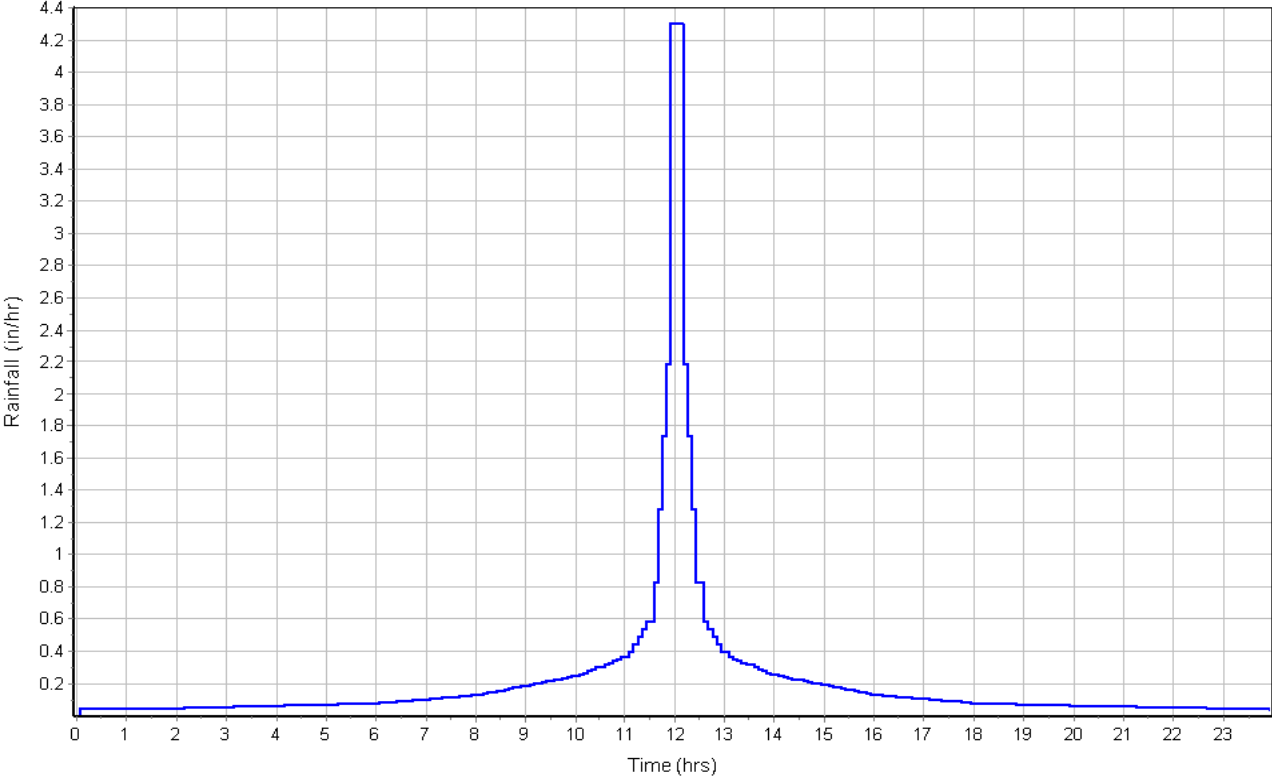

Runoff Hydrograph

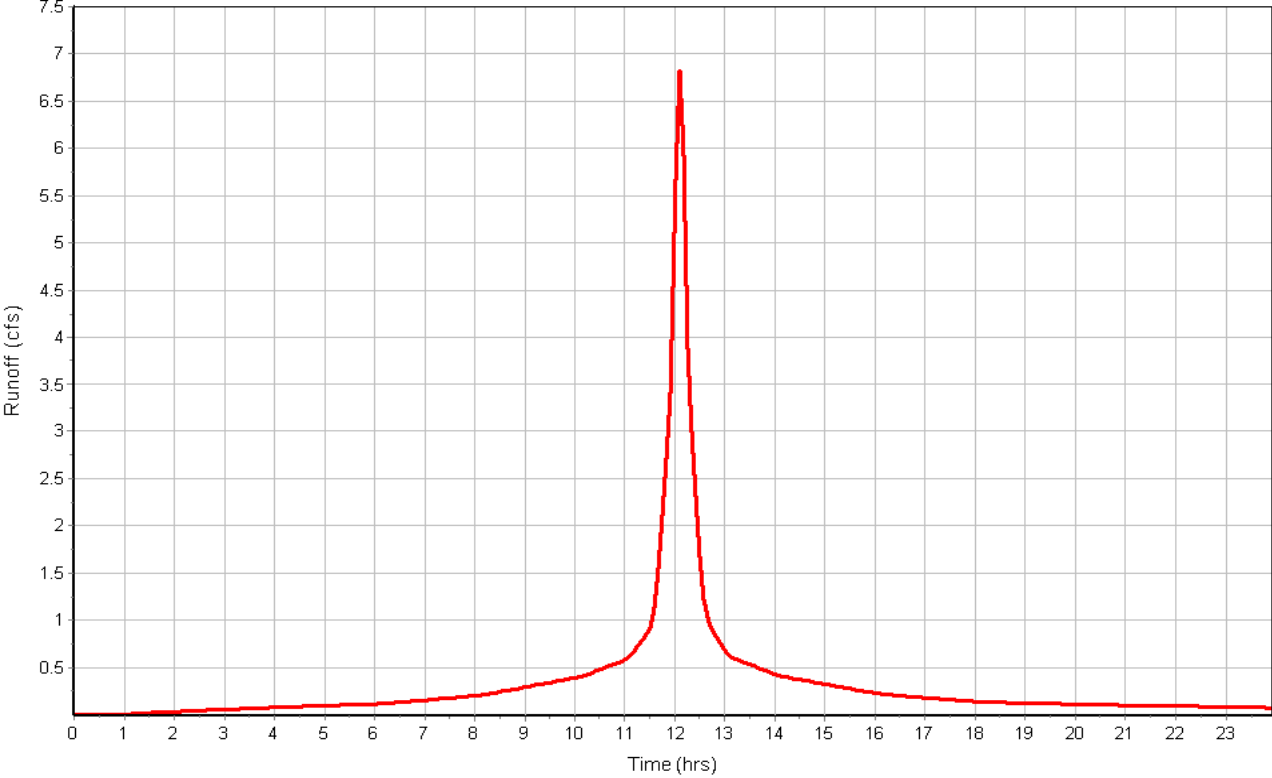

Subbasin : Sub-05

Input Data

Area (ac) 0.52
Weighted Curve Number 82.55
Average Slope (%) 1.6000
Flow Length (ft) 214.00
Rain Gage ID Rain Gage-01

Composite Curve Number

Soil/Surface Description	Area (acres)	Soil Group	Curve Number
Paved parking & roofs	0.38	A	98.00
> 75% grass cover, Good	0.14	A	39.00
Composite Area & Weighted CN	0.52		82.55

Time of Concentration

User-Defined TOC override (minutes): 6.00

Subbasin Runoff Results

Total Rainfall (in) 5.12
Total Runoff (in) 3.24
Peak Runoff (cfs) 1.71
Weighted Curve Number 82.55
Time of Concentration (days hh:mm:ss) 0 00:06:00

Subbasin : Sub-05

Rainfall Intensity Graph

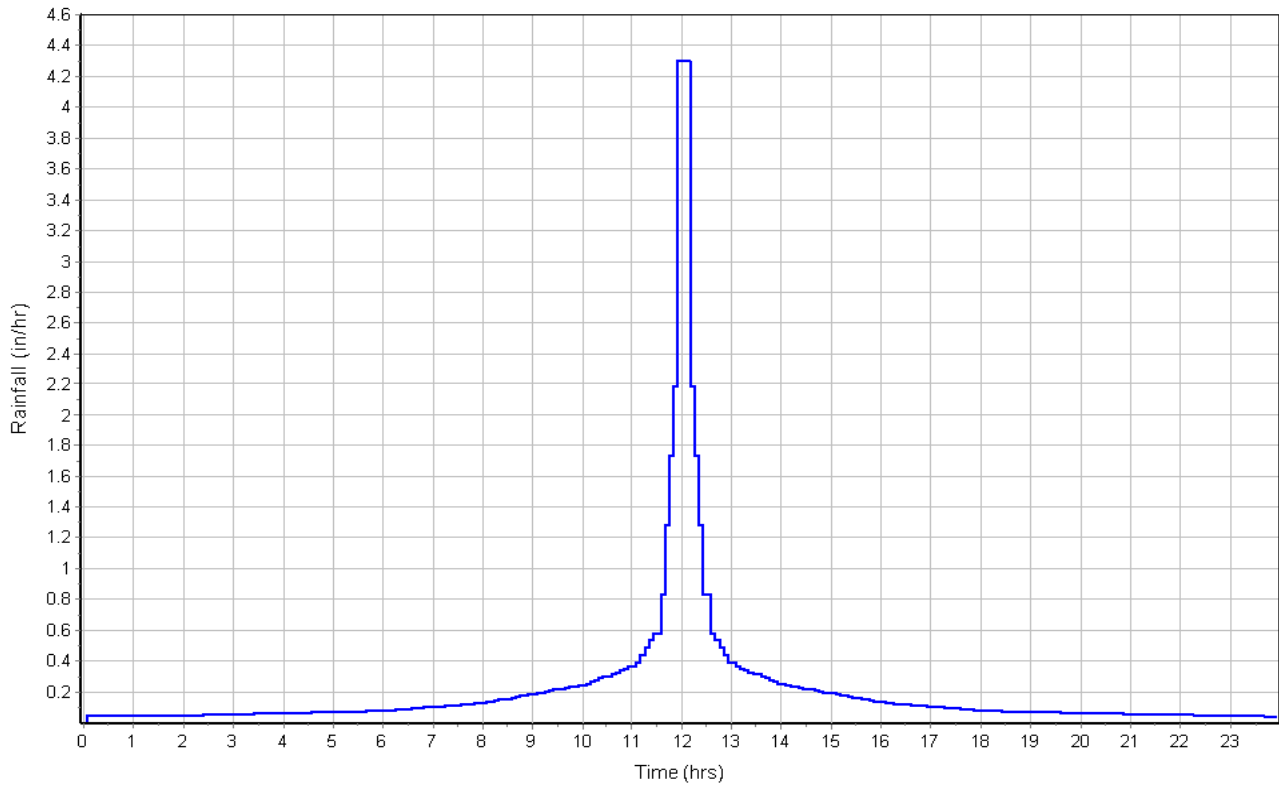

Runoff Hydrograph

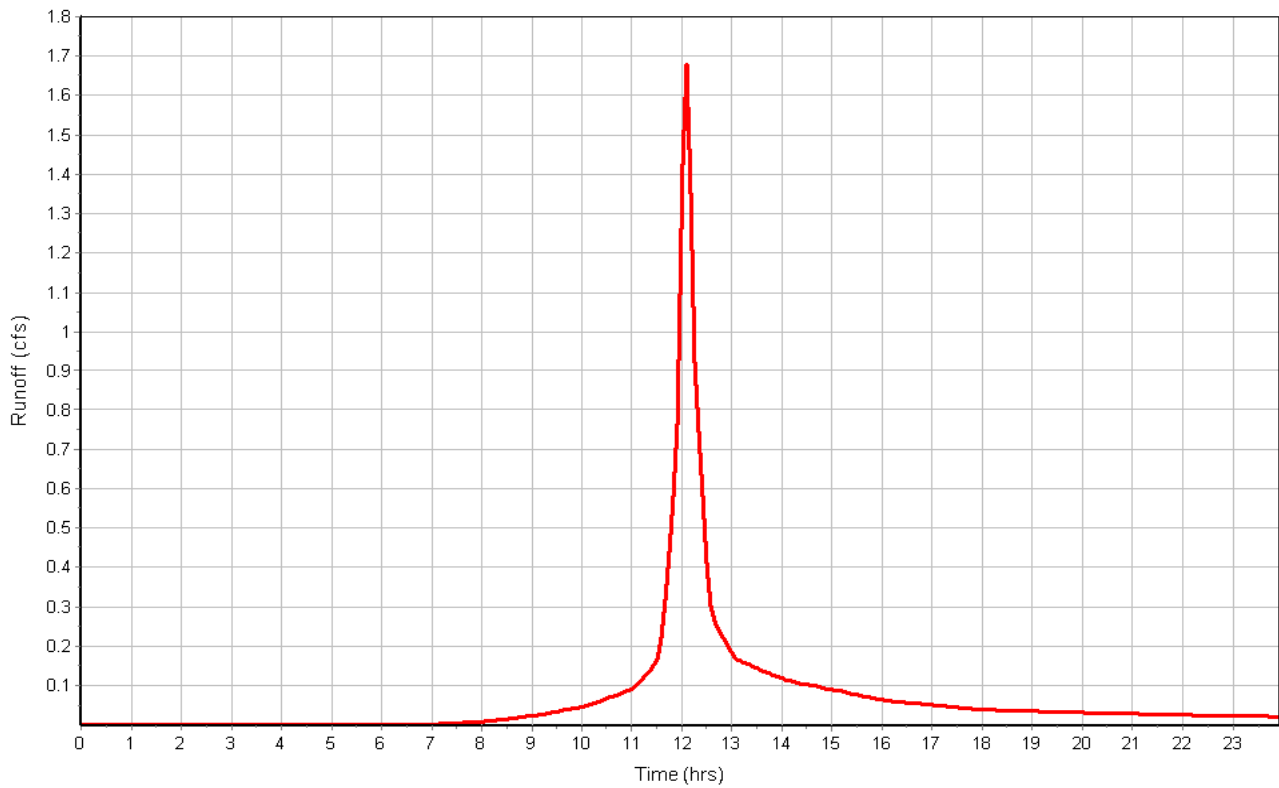

Subbasin : Sub-07

Input Data

Area (ac) 0.02
Weighted Curve Number 98.00
Average Slope (%) 2.2000
Flow Length (ft) 59.00
Rain Gage ID Rain Gage-01

Composite Curve Number

Soil/Surface Description	Area (acres)	Soil Group	Curve Number
Paved parking & roofs	0.02	A	98.00
Composite Area & Weighted CN	0.02		98.00

Time of Concentration

User-Defined TOC override (minutes): 6

Subbasin Runoff Results

Total Rainfall (in) 5.12
Total Runoff (in) 4.72
Peak Runoff (cfs) 0.08
Weighted Curve Number 98.00
Time of Concentration (days hh:mm:ss) 0 00:06:00

Subbasin : Sub-07

Rainfall Intensity Graph

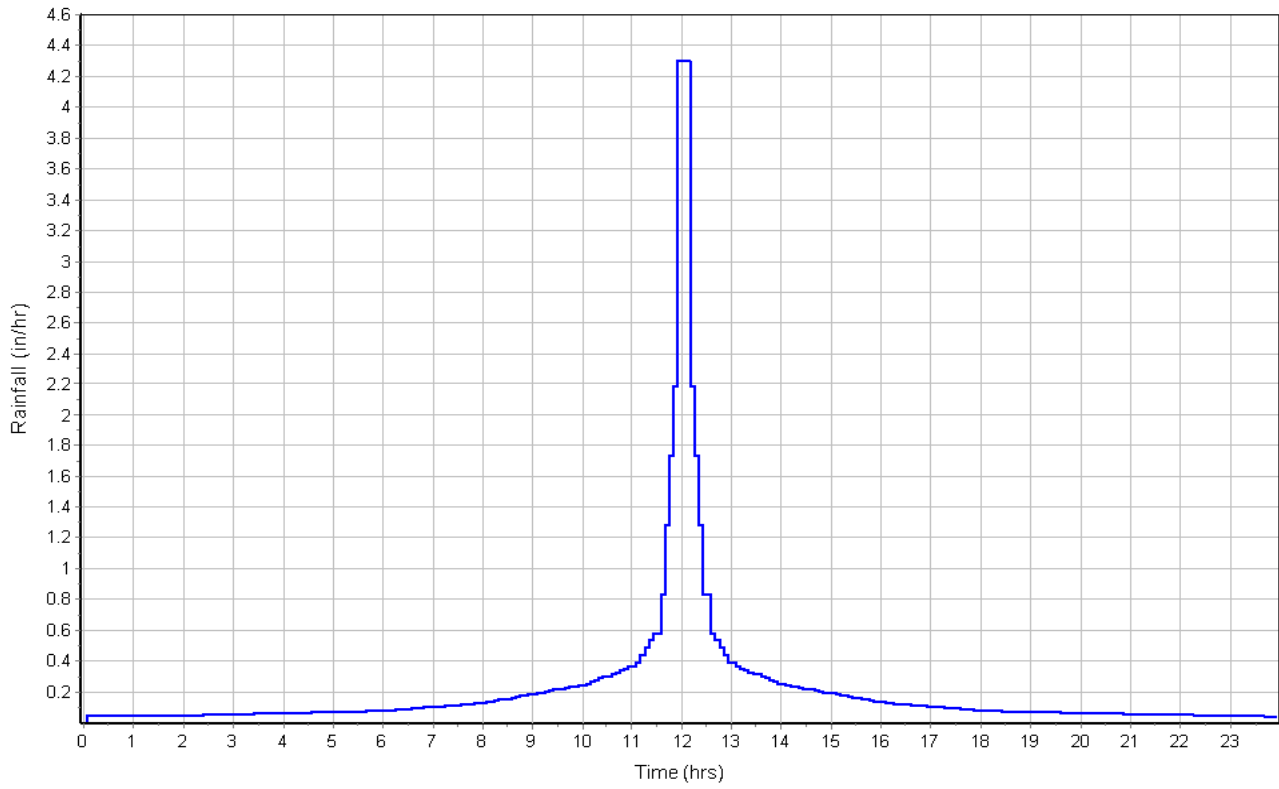

Runoff Hydrograph

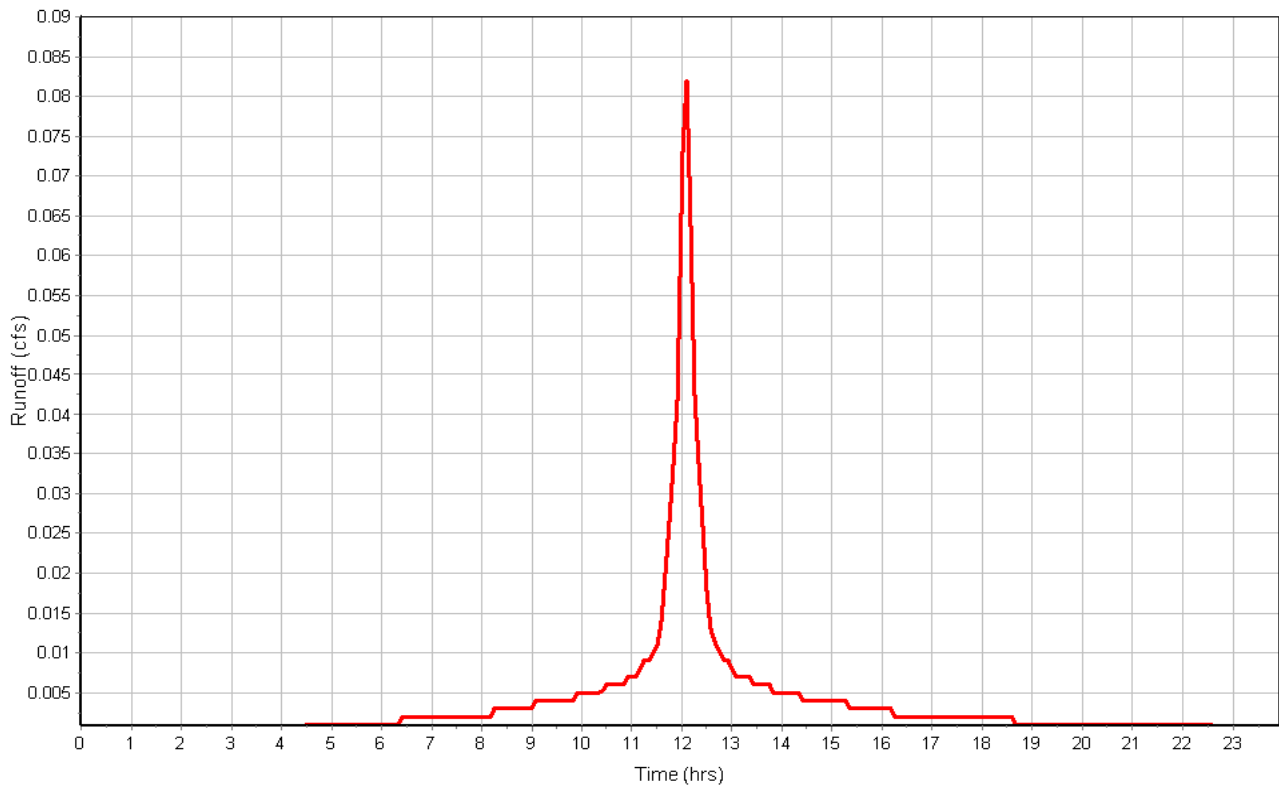

Subbasin : Sub-09

Input Data

Area (ac) 0.21
Weighted Curve Number 95.61
Average Slope (%) 0.5000
Flow Length (ft) 500.00
Rain Gage ID Rain Gage-01

Composite Curve Number

Soil/Surface Description	Area (acres)	Soil Group	Curve Number
> 75% grass cover, Good	0.01	A	39.00
Paved parking & roofs	0.21	A	98.00
Composite Area & Weighted CN	0.22		95.61

Time of Concentration

User-Defined TOC override (minutes): 6

Subbasin Runoff Results

Total Rainfall (in) 5.12
Total Runoff (in) 4.61
Peak Runoff (cfs) 0.91
Weighted Curve Number 95.61
Time of Concentration (days hh:mm:ss) 0 00:06:00

Subbasin : Sub-09

Rainfall Intensity Graph

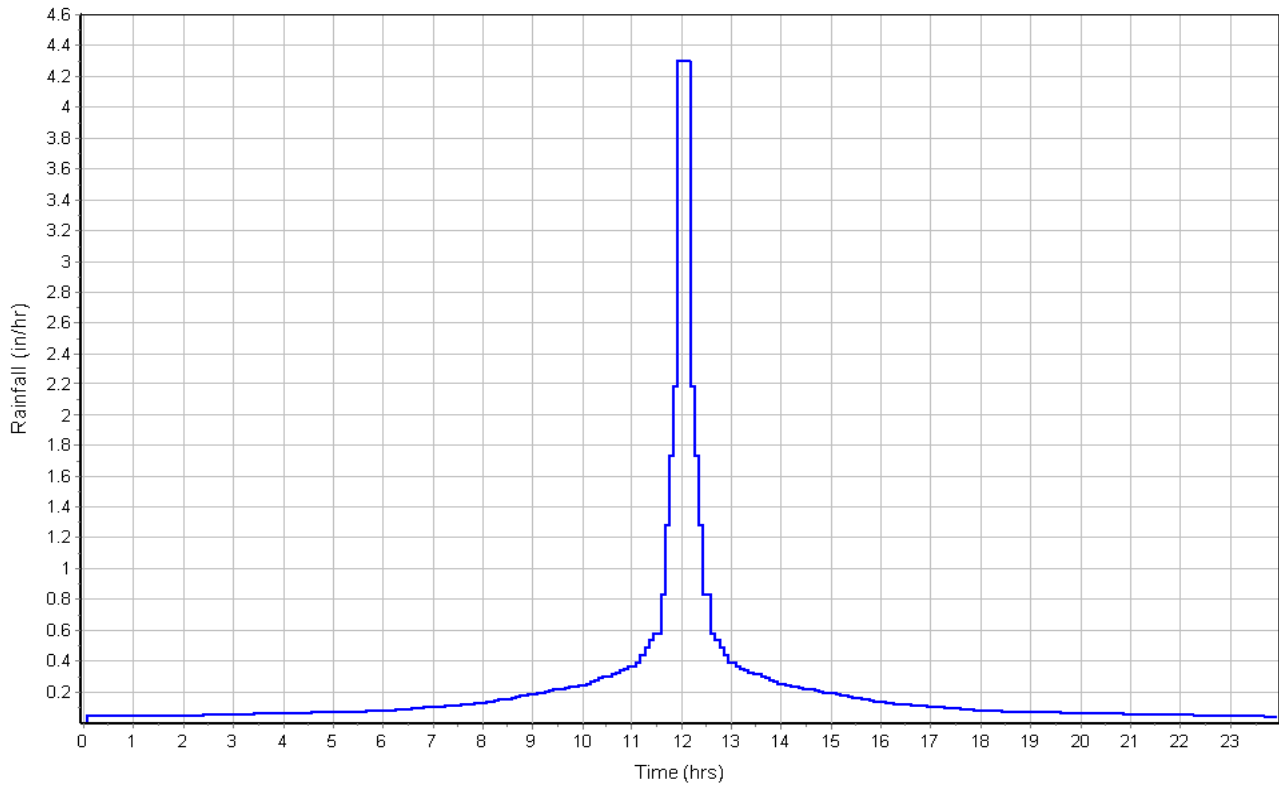

Runoff Hydrograph

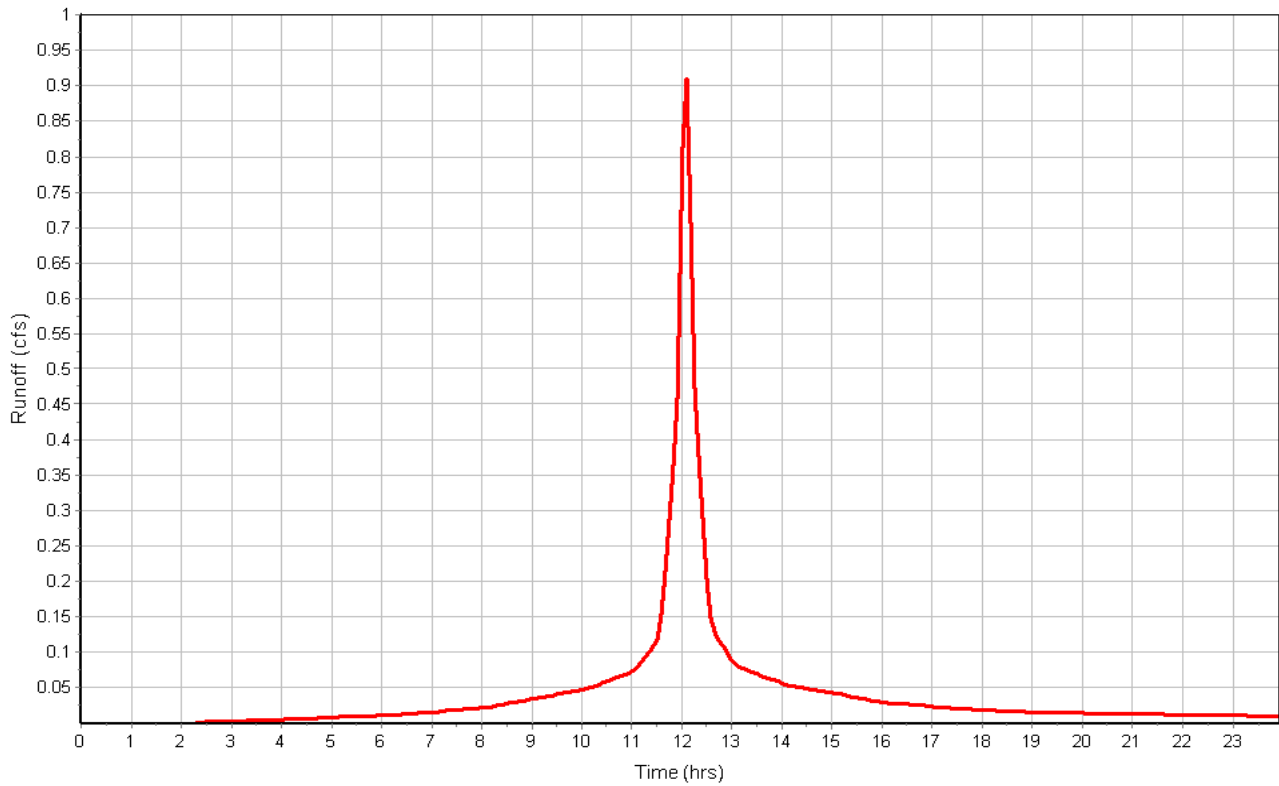

Subbasin : Sub-10

Input Data

Area (ac) 0.17
Weighted Curve Number 93.26
Average Slope (%) 1.4400
Flow Length (ft) 138.00
Rain Gage ID Rain Gage-01

Composite Curve Number

Soil/Surface Description	Area (acres)	Soil Group	Curve Number
> 75% grass cover, Good	0.01	A	39.00
Paved parking & roofs	0.16	A	98.00
Composite Area & Weighted CN	0.17		93.26

Time of Concentration

Flow Length (ft) 138.00
Slope (%) 1.44
Computed TOC (min) 1.77

Subbasin Runoff Results

Total Rainfall (in) 5.12
Total Runoff (in) 4.34
Peak Runoff (cfs) 0.71
Weighted Curve Number 93.26
Time of Concentration (days hh:mm:ss) 0 00:01:46

Subbasin : Sub-10

Rainfall Intensity Graph

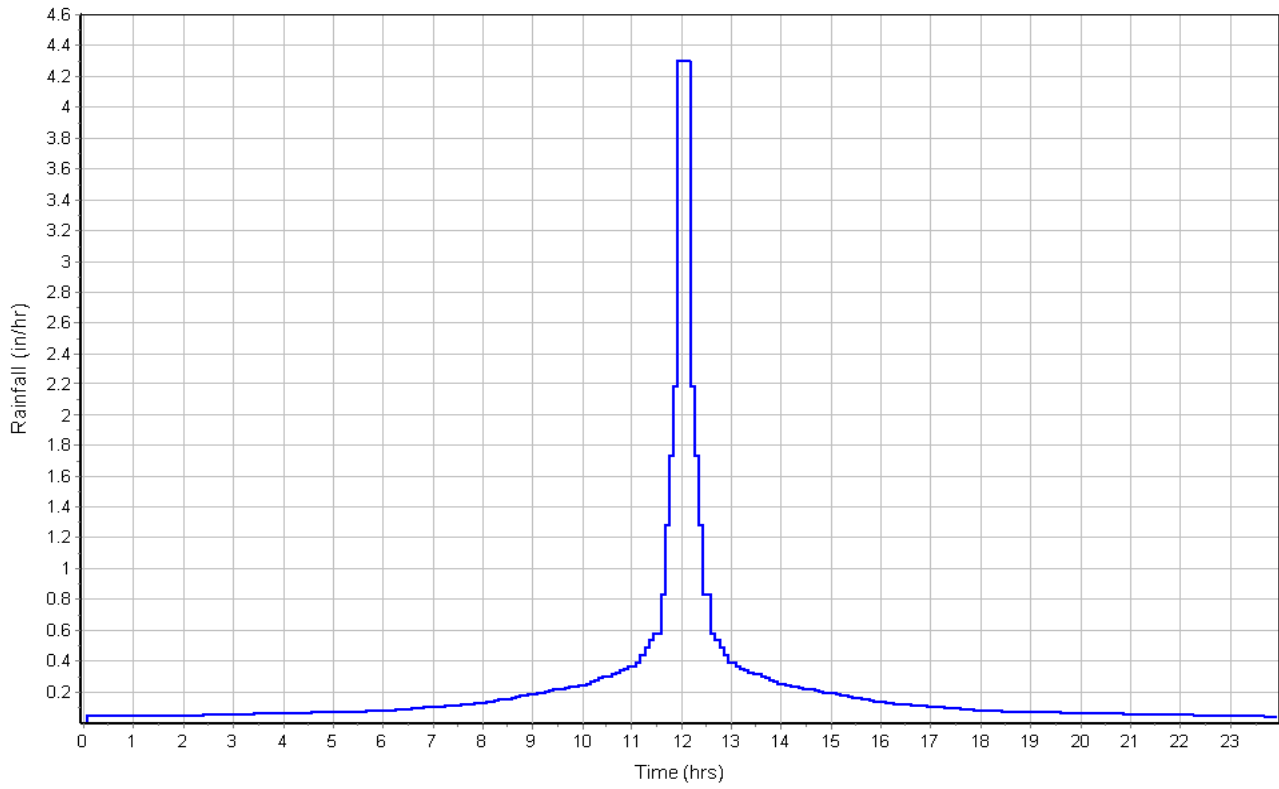

Runoff Hydrograph

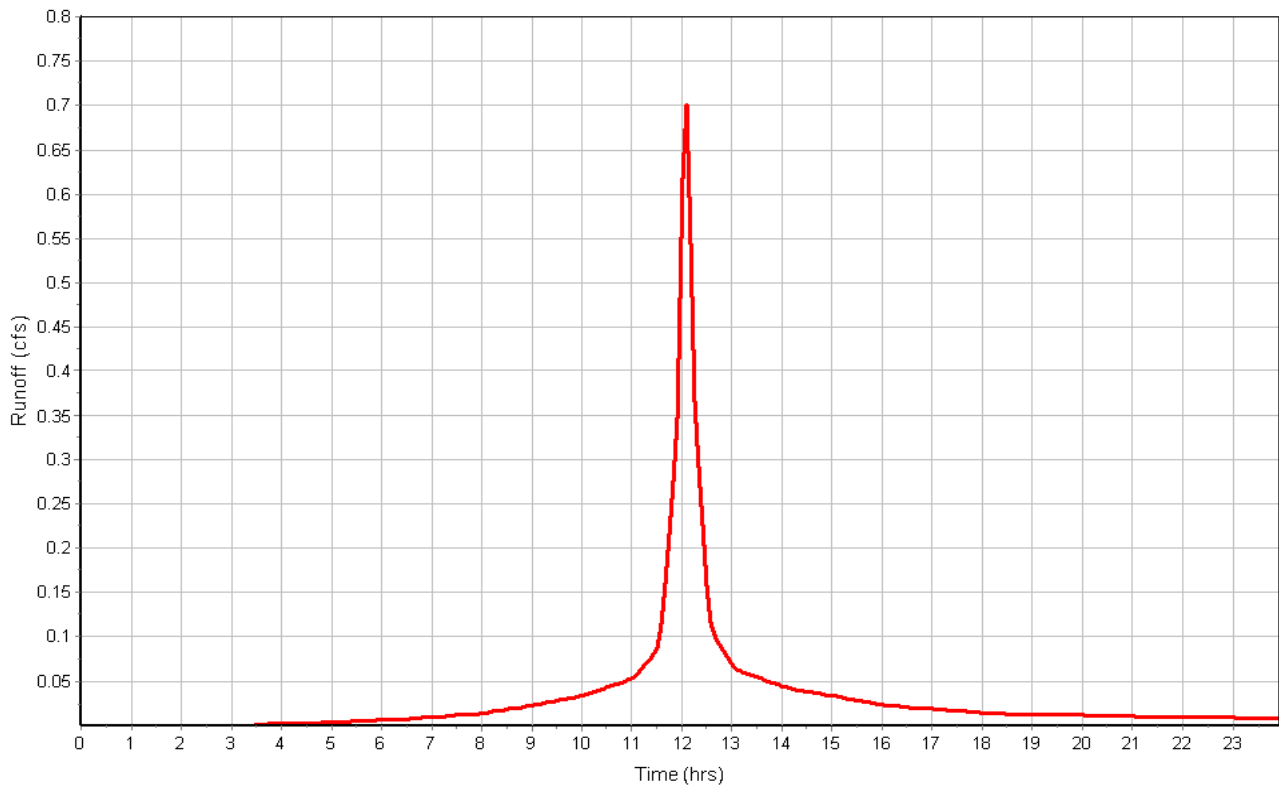

Subbasin : Sub-11

Input Data

Area (ac) 0.10
Weighted Curve Number 96.56
Average Slope (%) 0.5000
Flow Length (ft) 500.00
Rain Gage ID Rain Gage-01

Composite Curve Number

Soil/Surface Description	Area (acres)	Soil Group	Curve Number
Paved parking & roofs	0.10	A	98.00
> 75% grass cover, Good	0.00	A	39.00
Composite Area & Weighted CN	0.10		96.56

Time of Concentration

User-Defined TOC override (minutes): 6.00

Subbasin Runoff Results

Total Rainfall (in) 5.12
Total Runoff (in) 4.71
Peak Runoff (cfs) 0.41
Weighted Curve Number 96.56
Time of Concentration (days hh:mm:ss) 0 00:06:00

Subbasin : Sub-11

Rainfall Intensity Graph

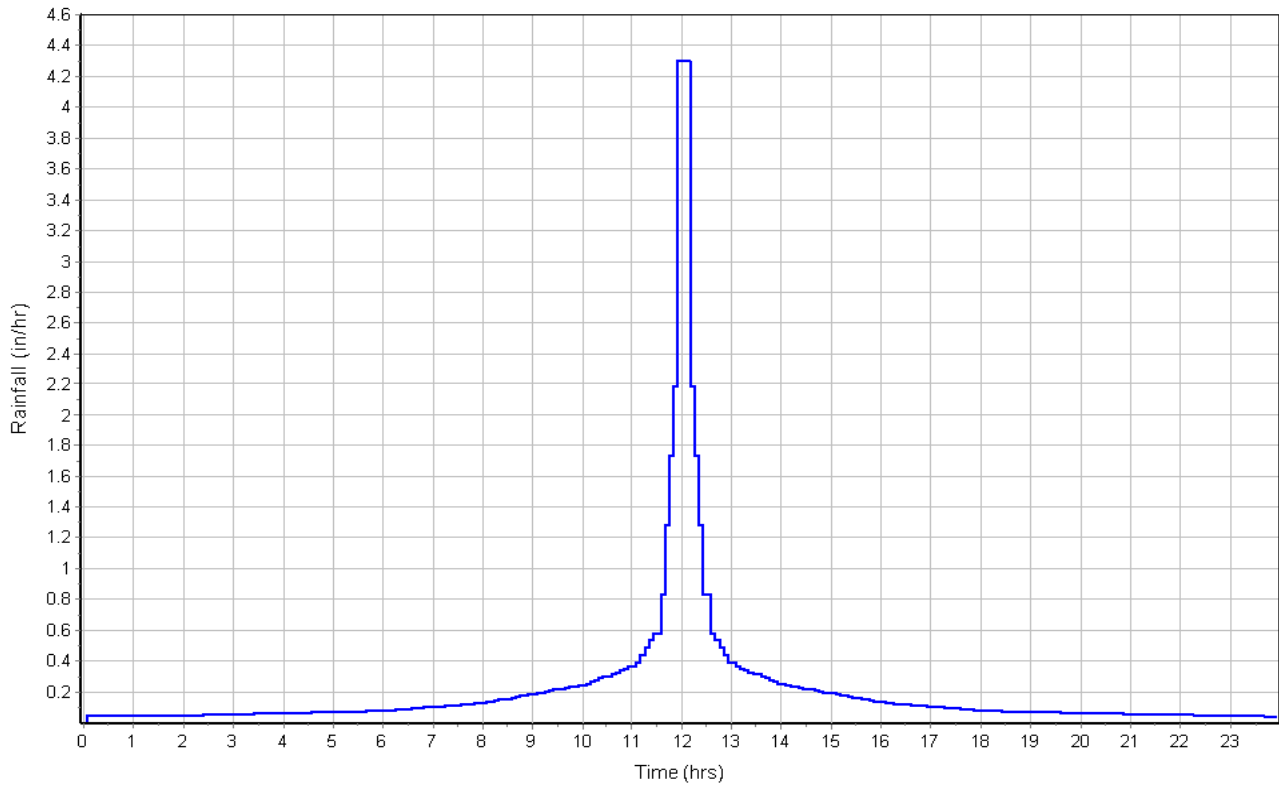

Runoff Hydrograph

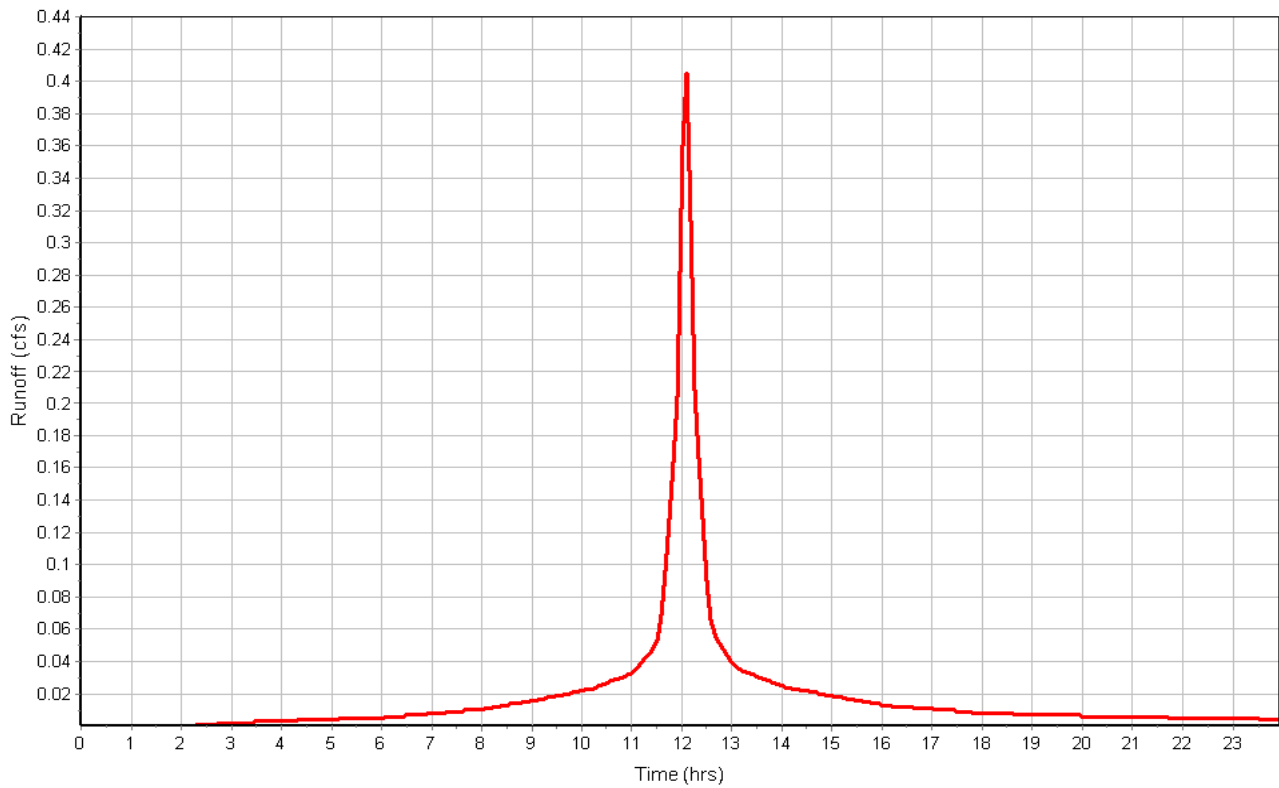

Subbasin : Sub-13

Input Data

Area (ac) 0.08
Weighted Curve Number 90.00
Average Slope (%) 0.5000
Flow Length (ft) 500.00
Rain Gage ID Rain Gage-01

Composite Curve Number

Soil/Surface Description	Area (acres)	Soil Group	Curve Number
-	5.00	-	90.00
Composite Area & Weighted CN	5.00		90.00

Time of Concentration

Flow Length (ft) 500.00
Slope (%) 0.5
Computed TOC (min) 7.18

Subbasin Runoff Results

Total Rainfall (in) 5.12
Total Runoff (in) 3.98
Peak Runoff (cfs) 0.29
Weighted Curve Number 90.00
Time of Concentration (days hh:mm:ss) 0 00:07:11

Subbasin : Sub-13

Rainfall Intensity Graph

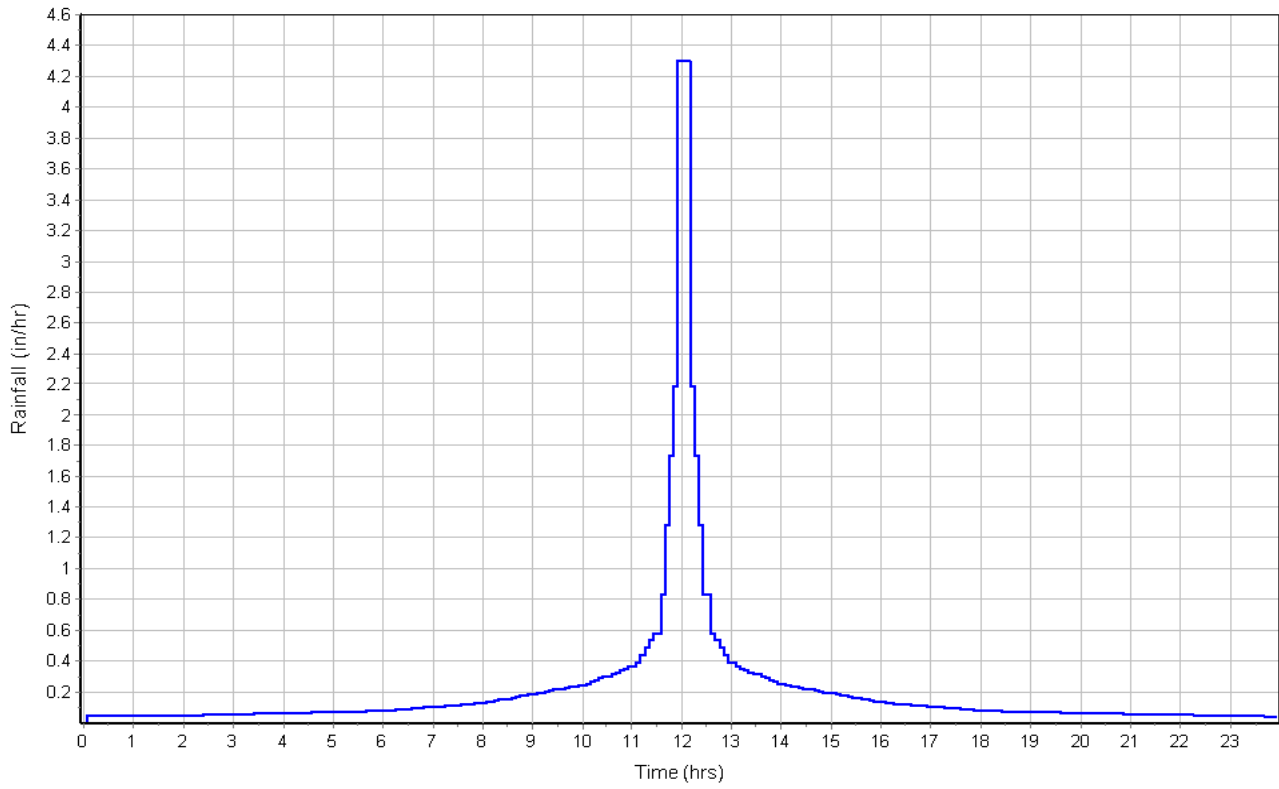

Runoff Hydrograph

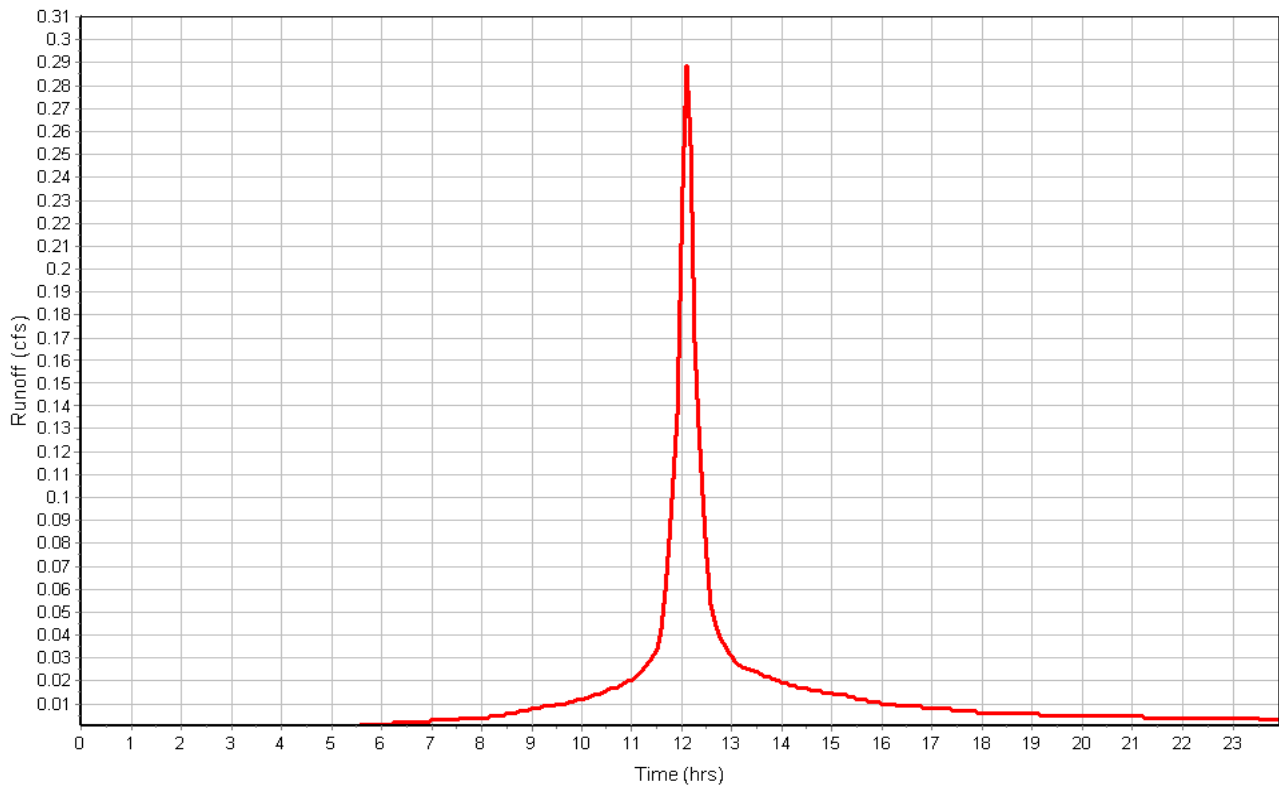

Subbasin : Sub-14

Input Data

Area (ac) 0.09
Weighted Curve Number 95.00
Average Slope (%) 0.5000
Flow Length (ft) 500.00
Rain Gage ID Rain Gage-01

Composite Curve Number

Soil/Surface Description	Area (acres)	Soil Group	Curve Number
-	5.00	-	95.00
Composite Area & Weighted CN	5.00		95.00

Time of Concentration

Flow Length (ft) 500.00
Slope (%) 0.5
Computed TOC (min) 7.18

Subbasin Runoff Results

Total Rainfall (in) 5.12
Total Runoff (in) 4.53
Peak Runoff (cfs) 0.37
Weighted Curve Number 95.00
Time of Concentration (days hh:mm:ss) 0 00:07:11

Subbasin : Sub-14

Rainfall Intensity Graph

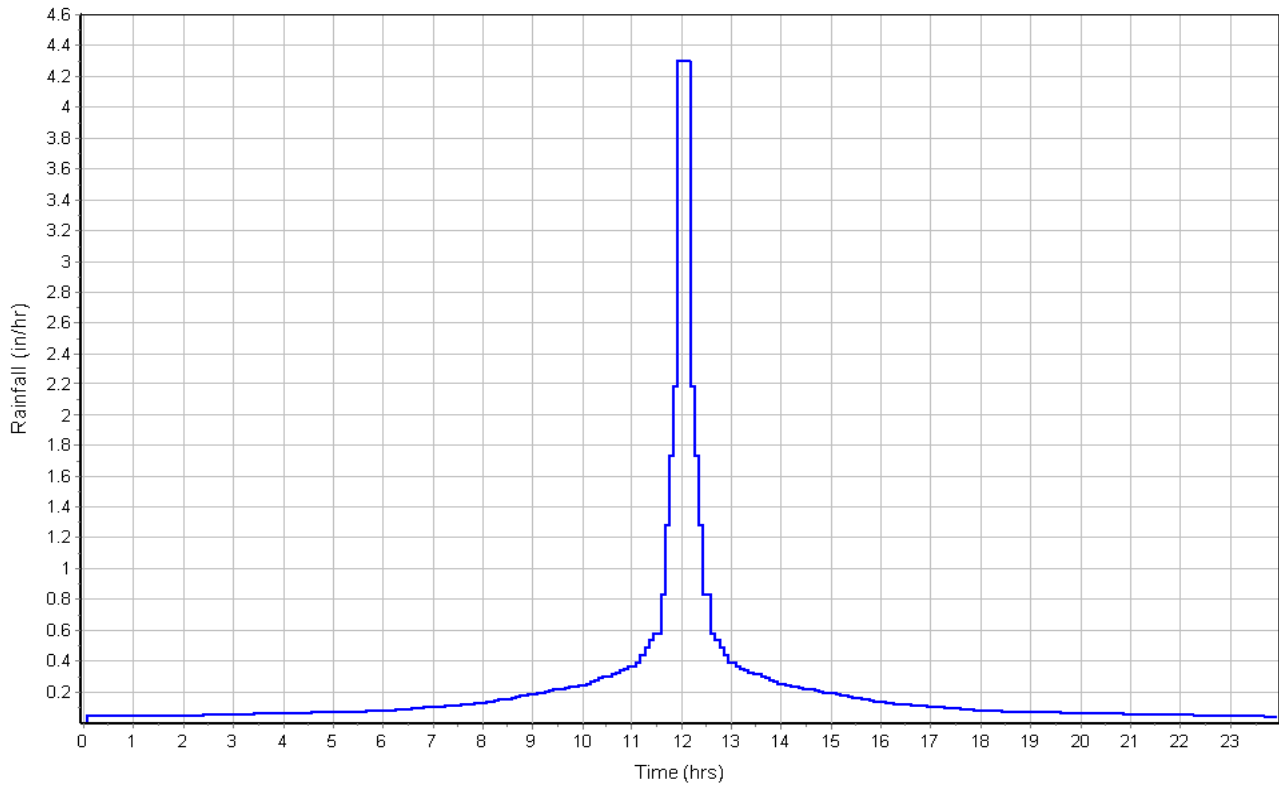

Runoff Hydrograph

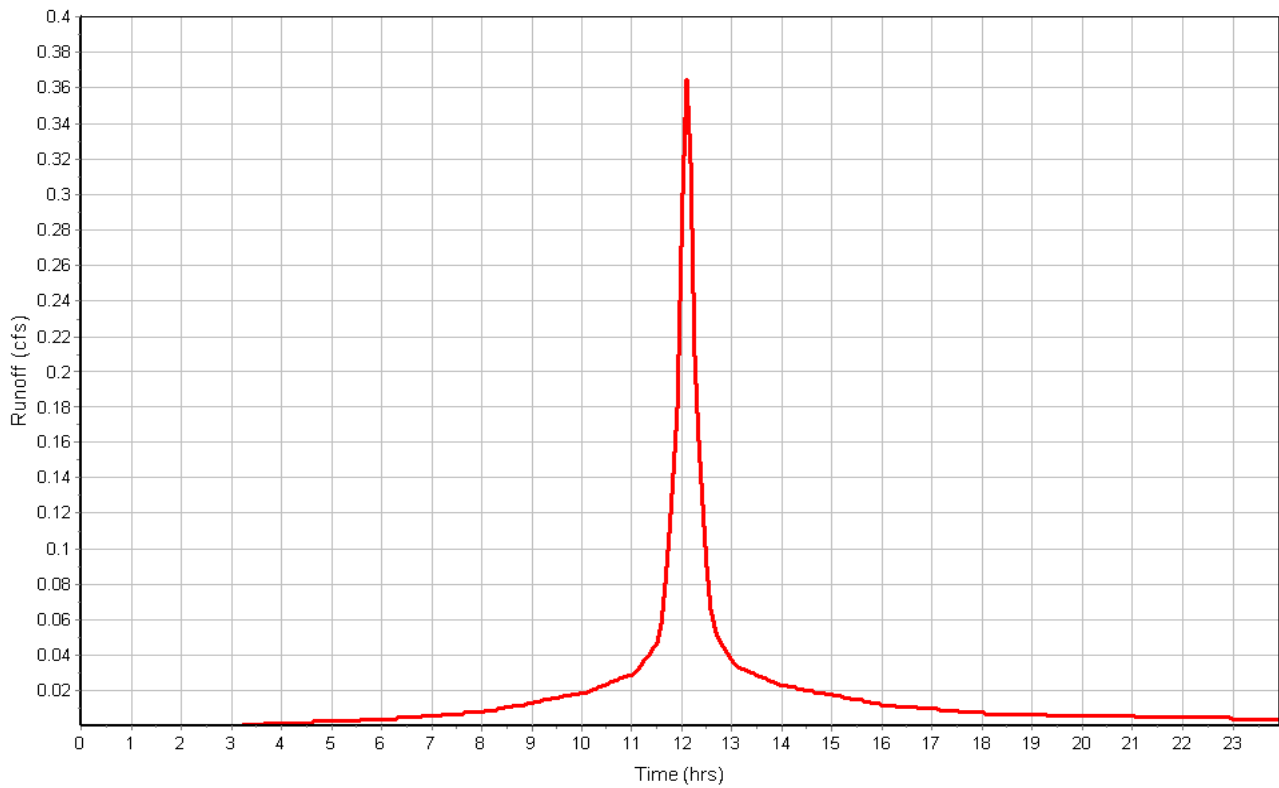

Subbasin : Sub-16

Input Data

Area (ac) 0.16
Weighted Curve Number 87.87
Average Slope (%) 1.2400
Flow Length (ft) 253.00
Rain Gage ID Rain Gage-01

Composite Curve Number

Soil/Surface Description	Area (acres)	Soil Group	Curve Number
> 75% grass cover, Good	0.03	A	39.00
Paved parking & roofs	0.13	A	98.00
Composite Area & Weighted CN	0.16		87.87

Time of Concentration

User-Defined TOC override (minutes): 6

Subbasin Runoff Results

Total Rainfall (in) 5.12
Total Runoff (in) 3.77
Peak Runoff (cfs) 0.60
Weighted Curve Number 87.87
Time of Concentration (days hh:mm:ss) 0 00:06:00

Subbasin : Sub-16

Rainfall Intensity Graph

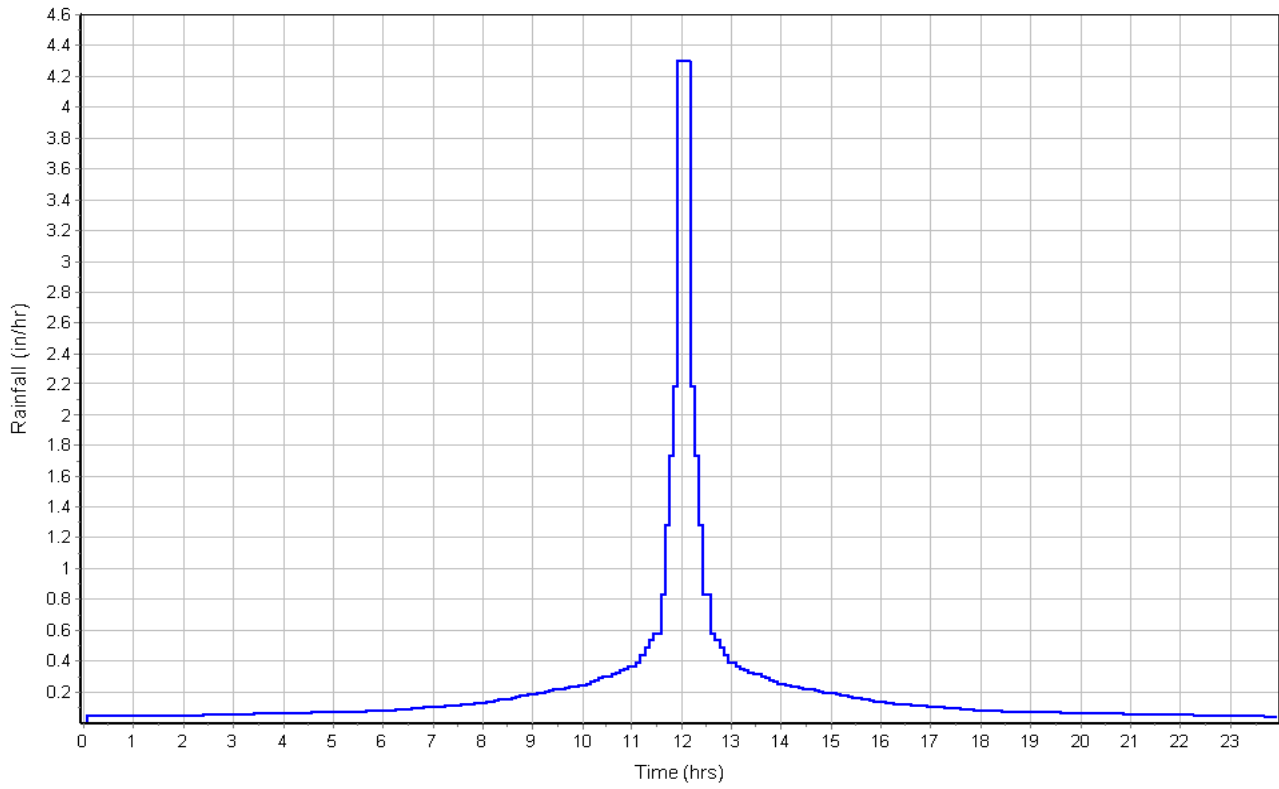

Runoff Hydrograph

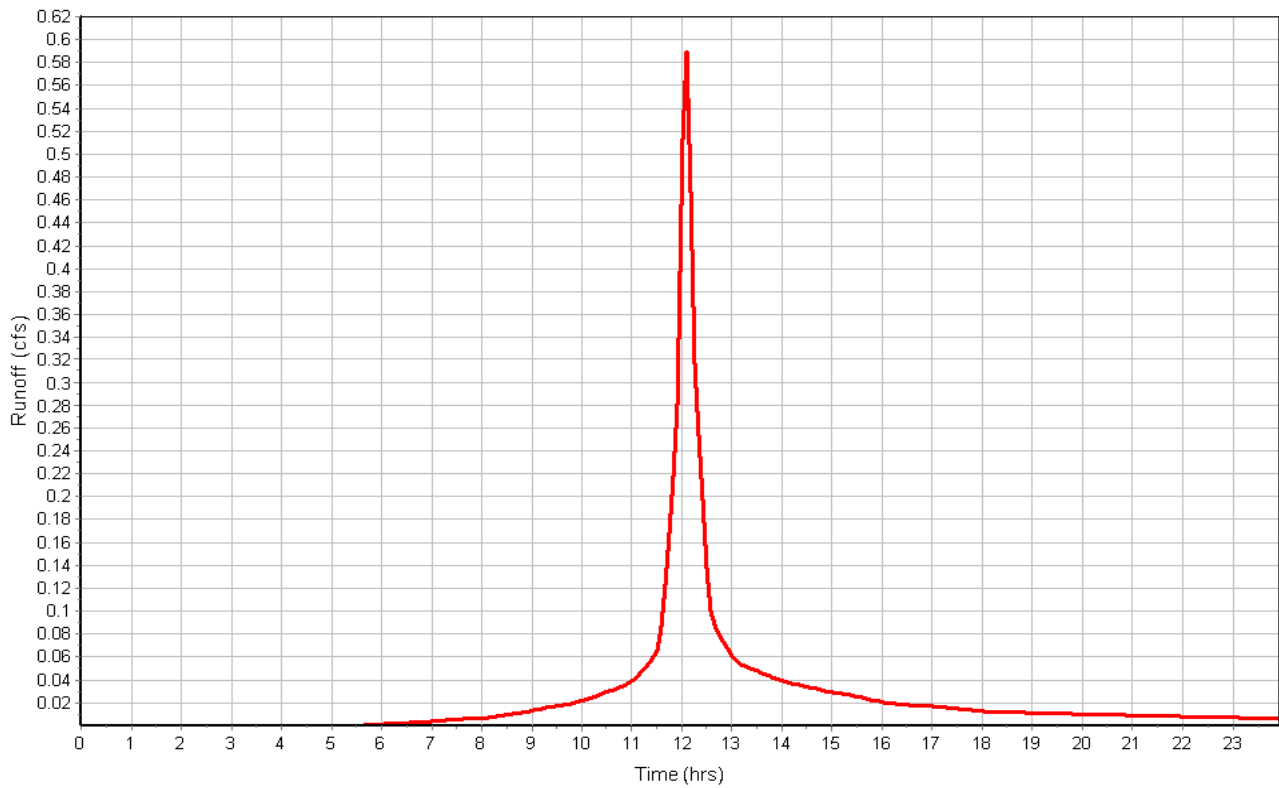

Subbasin : Sub-17

Input Data

Area (ac) 0.25
Weighted Curve Number 97.00
Average Slope (%) 0.5000
Flow Length (ft) 500.00
Rain Gage ID Rain Gage-01

Composite Curve Number

Soil/Surface Description	Area (acres)	Soil Group	Curve Number
-	5.00	-	97.00
Composite Area & Weighted CN	5.00		97.00

Time of Concentration

Flow Length (ft) 500.00
Slope (%) 0.5
Computed TOC (min) 7.18

Subbasin Runoff Results

Total Rainfall (in) 5.12
Total Runoff (in) 4.77
Peak Runoff (cfs) 1.05
Weighted Curve Number 97.00
Time of Concentration (days hh:mm:ss) 0 00:07:11

Subbasin : Sub-17

Rainfall Intensity Graph

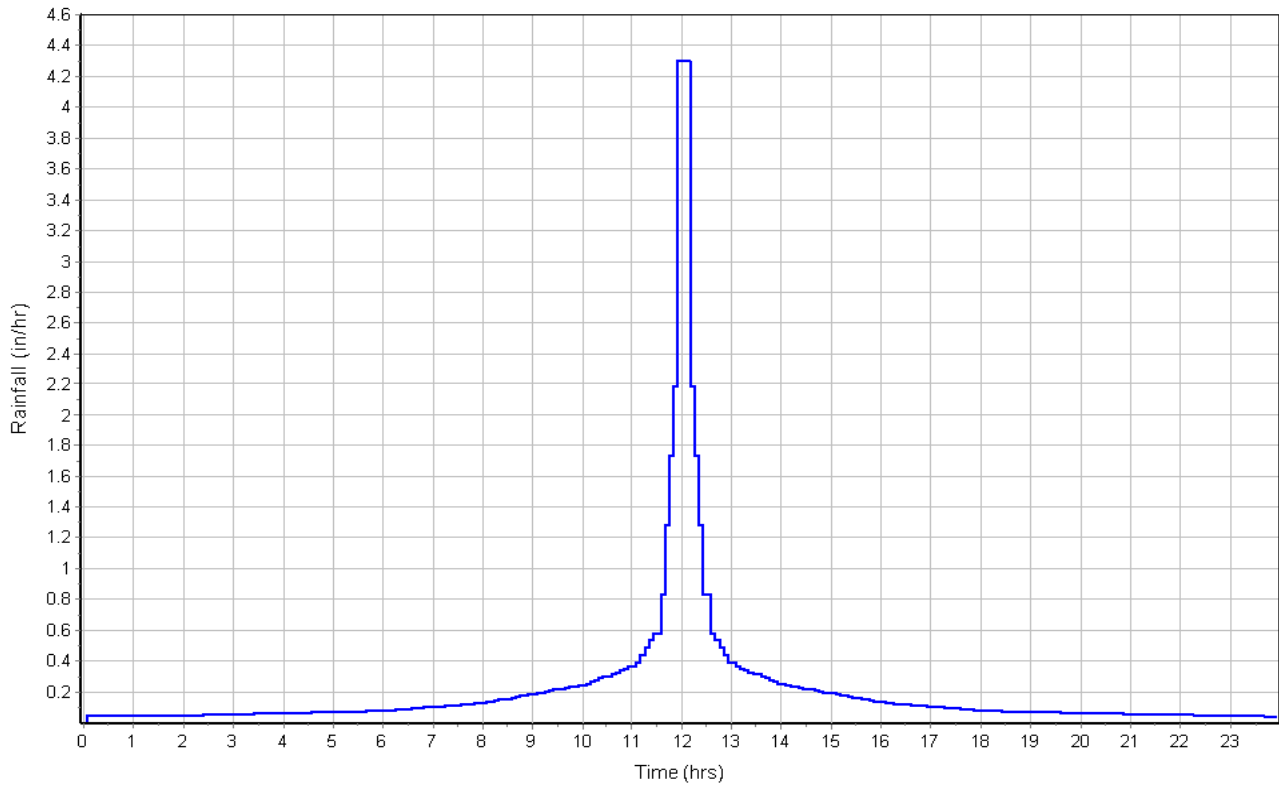

Runoff Hydrograph

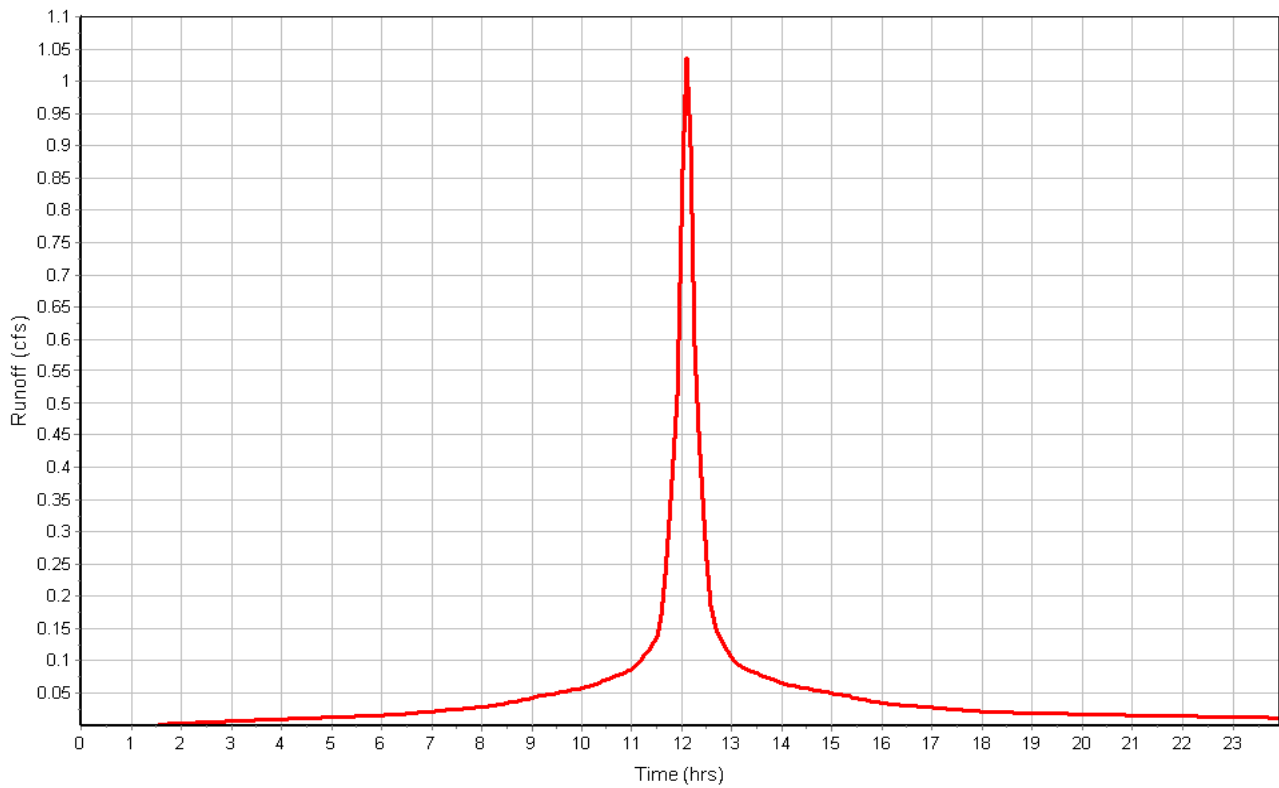

Subbasin : Sub-19

Input Data

Area (ac) 0.09
Weighted Curve Number 61.80
Average Slope (%) 0.0484
Flow Length (ft) 65.00
Rain Gage ID Rain Gage-01

Composite Curve Number

Soil/Surface Description	Area (acres)	Soil Group	Curve Number
Paved parking & roofs	0.04	A	98.00
> 75% grass cover, Good	0.06	A	39.00
Composite Area & Weighted CN	0.10		61.80

Time of Concentration

User-Defined TOC override (minutes): 6

Subbasin Runoff Results

Total Rainfall (in) 5.12
Total Runoff (in) 1.50
Peak Runoff (cfs) 0.13
Weighted Curve Number 61.80
Time of Concentration (days hh:mm:ss) 0 00:06:00

Subbasin : Sub-19

Rainfall Intensity Graph

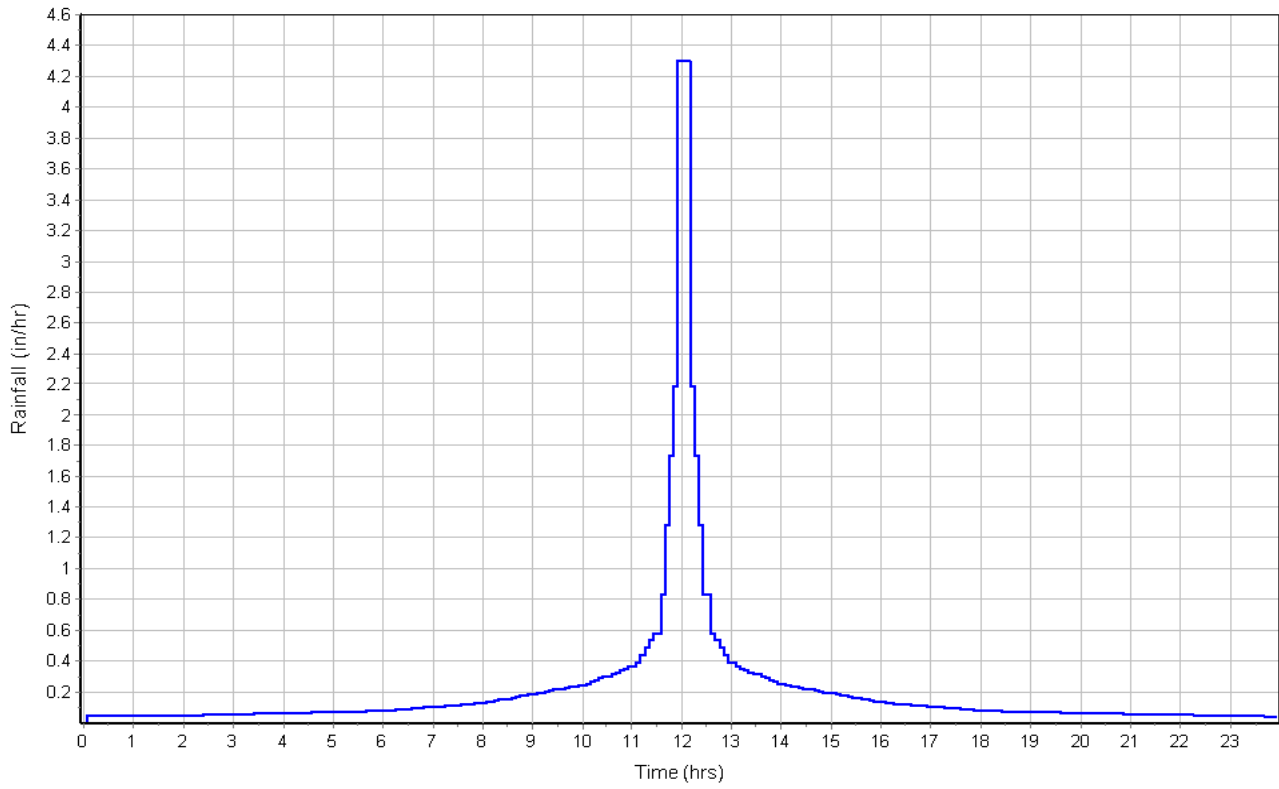

Runoff Hydrograph

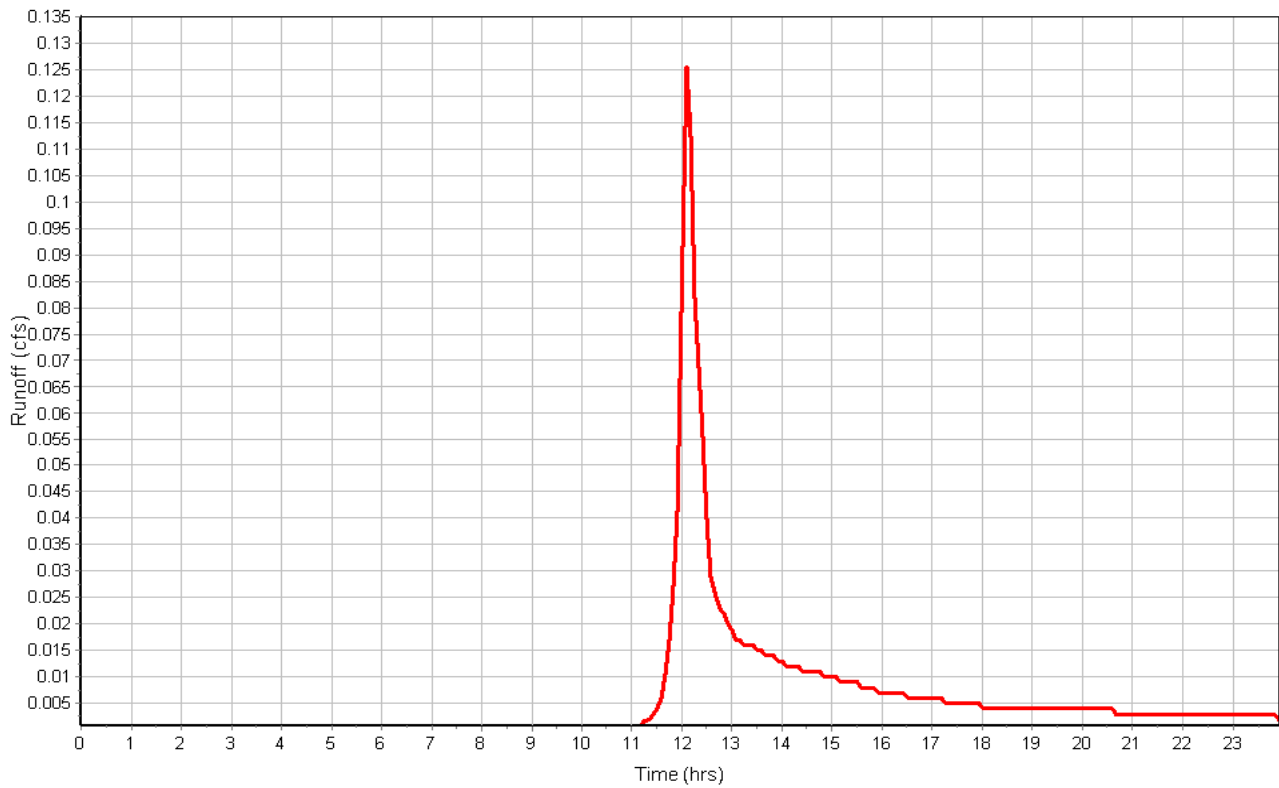

Subbasin : Sub-23

Input Data

Area (ac) 0.06
Weighted Curve Number 96.30
Average Slope (%) 2.8000
Flow Length (ft) 63.00
Rain Gage ID Rain Gage-01

Composite Curve Number

Soil/Surface Description	Area (acres)	Soil Group	Curve Number
Paved parking & roofs	0.06	A	98.00
> 75% grass cover, Good	0.00	A	39.00
Composite Area & Weighted CN	0.06		96.30

Time of Concentration

User-Defined TOC override (minutes): 6

Subbasin Runoff Results

Total Rainfall (in) 5.12
Total Runoff (in) 4.67
Peak Runoff (cfs) 0.24
Weighted Curve Number 96.30
Time of Concentration (days hh:mm:ss) 0 00:06:00

Subbasin : Sub-23

Rainfall Intensity Graph

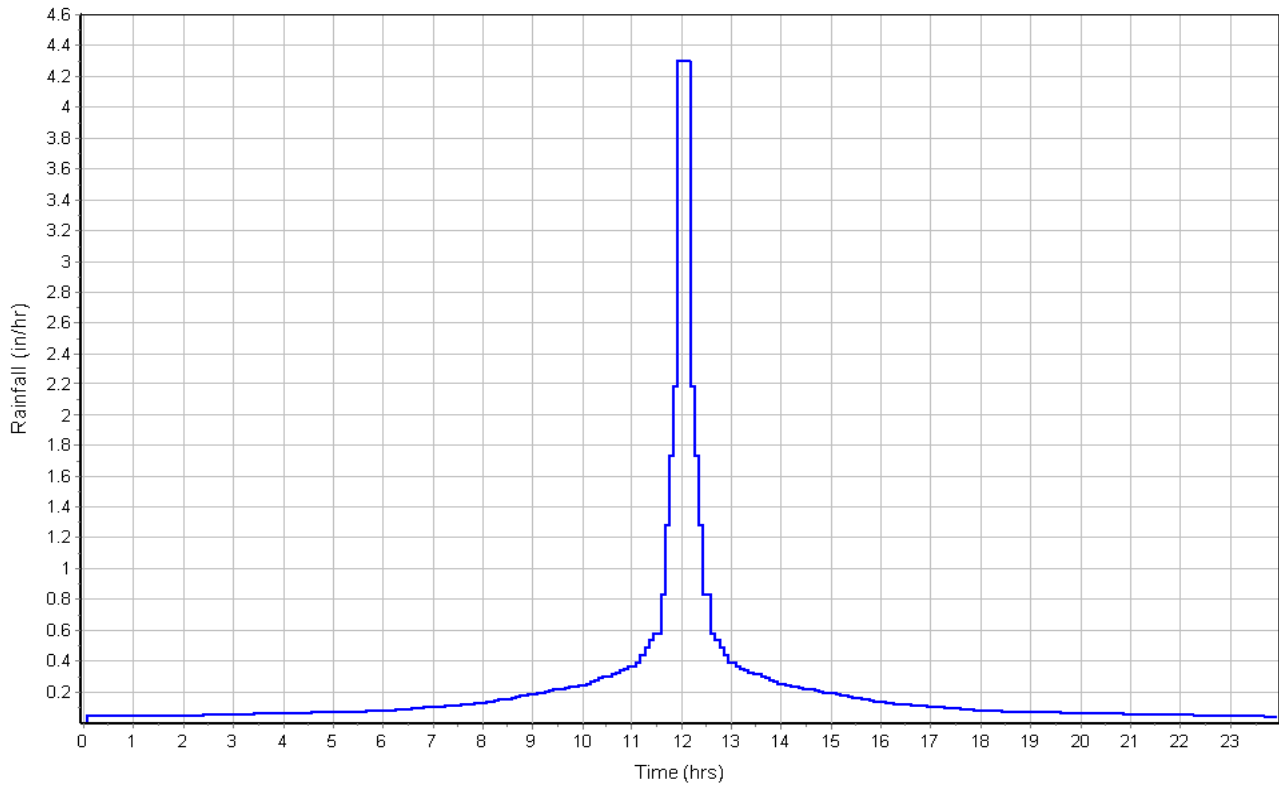

Runoff Hydrograph

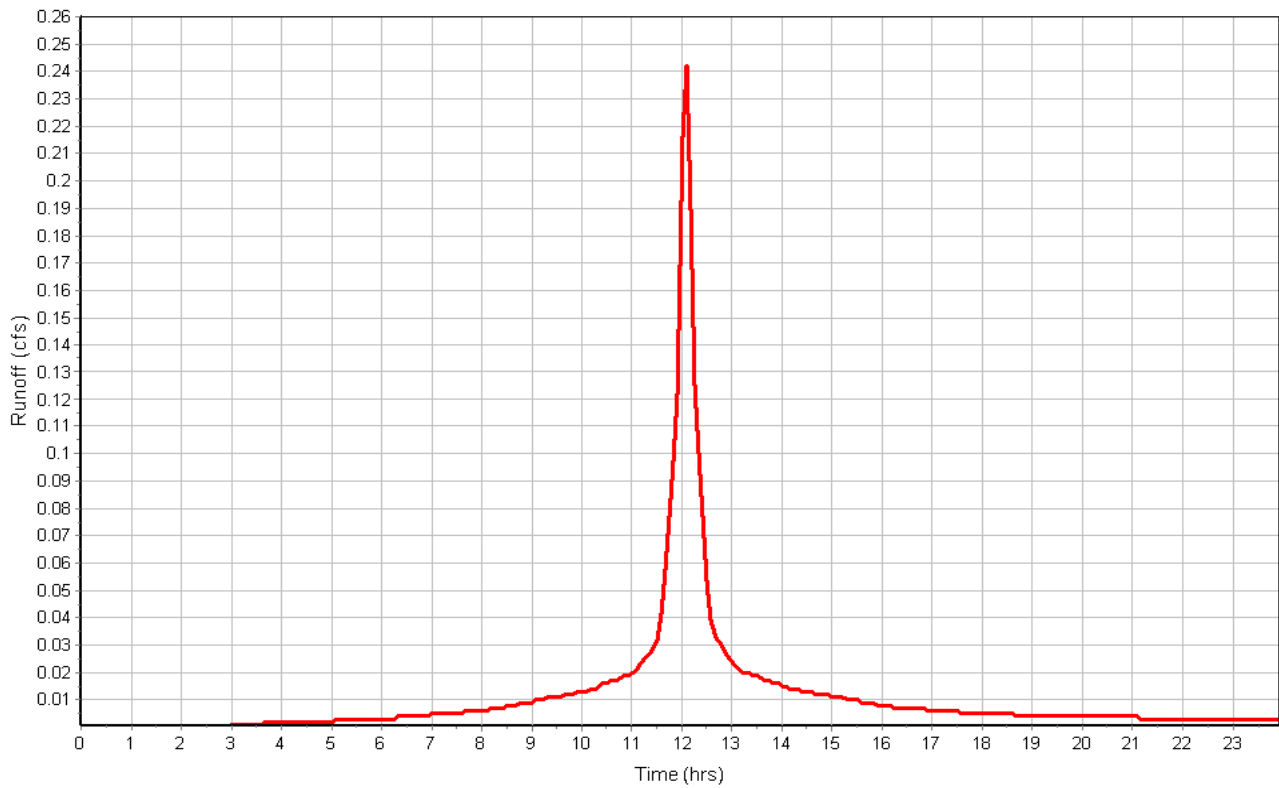

Subbasin : Sub-25

Input Data

Area (ac) 0.07
Weighted Curve Number 80.12
Average Slope (%) 3.6000
Flow Length (ft) 90.00
Rain Gage ID Rain Gage-01

Composite Curve Number

Soil/Surface Description	Area (acres)	Soil Group	Curve Number
> 75% grass cover, Good	0.02	A	39.00
Paved parking & roofs	0.05	A	98.00
Composite Area & Weighted CN	0.07		80.12

Time of Concentration

User-Defined TOC override (minutes): 6

Subbasin Runoff Results

Total Rainfall (in) 5.12
Total Runoff (in) 3.00
Peak Runoff (cfs) 0.20
Weighted Curve Number 80.12
Time of Concentration (days hh:mm:ss) 0 00:06:00

Subbasin : Sub-25

Rainfall Intensity Graph

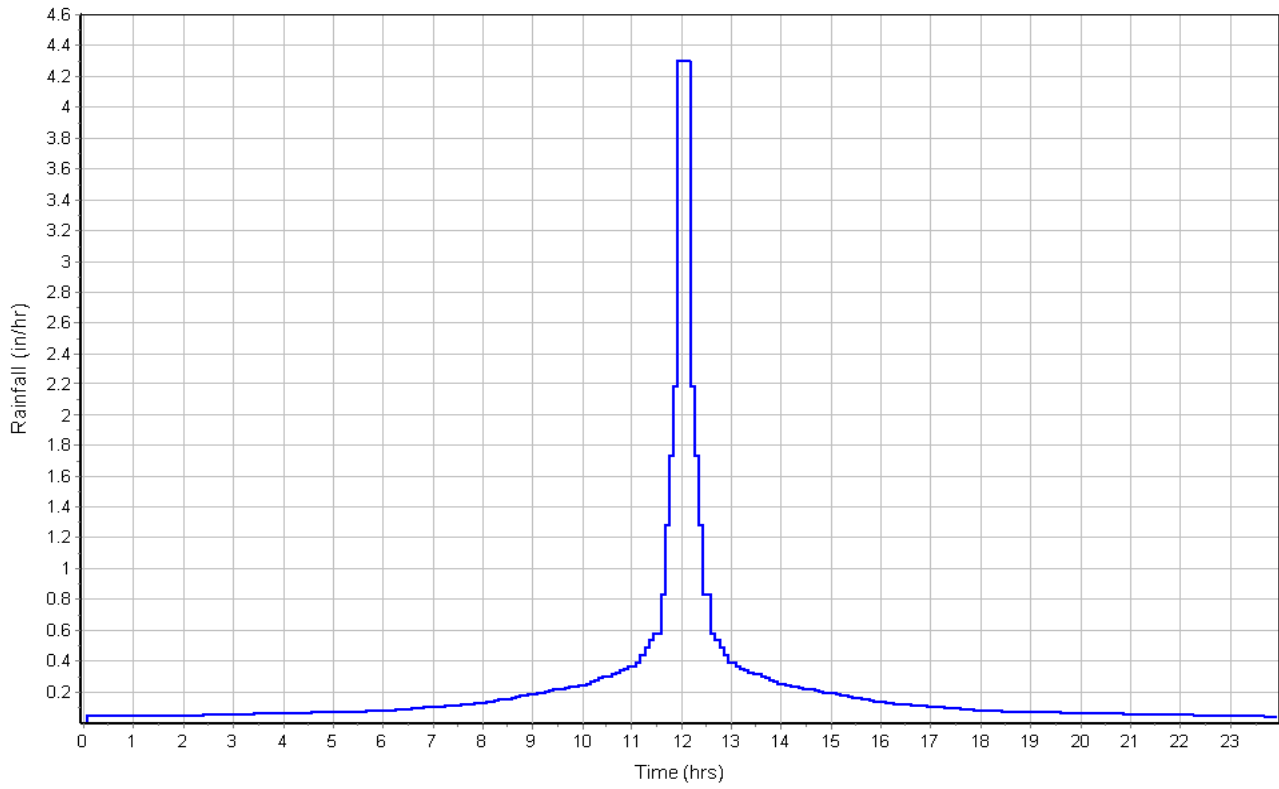

Runoff Hydrograph

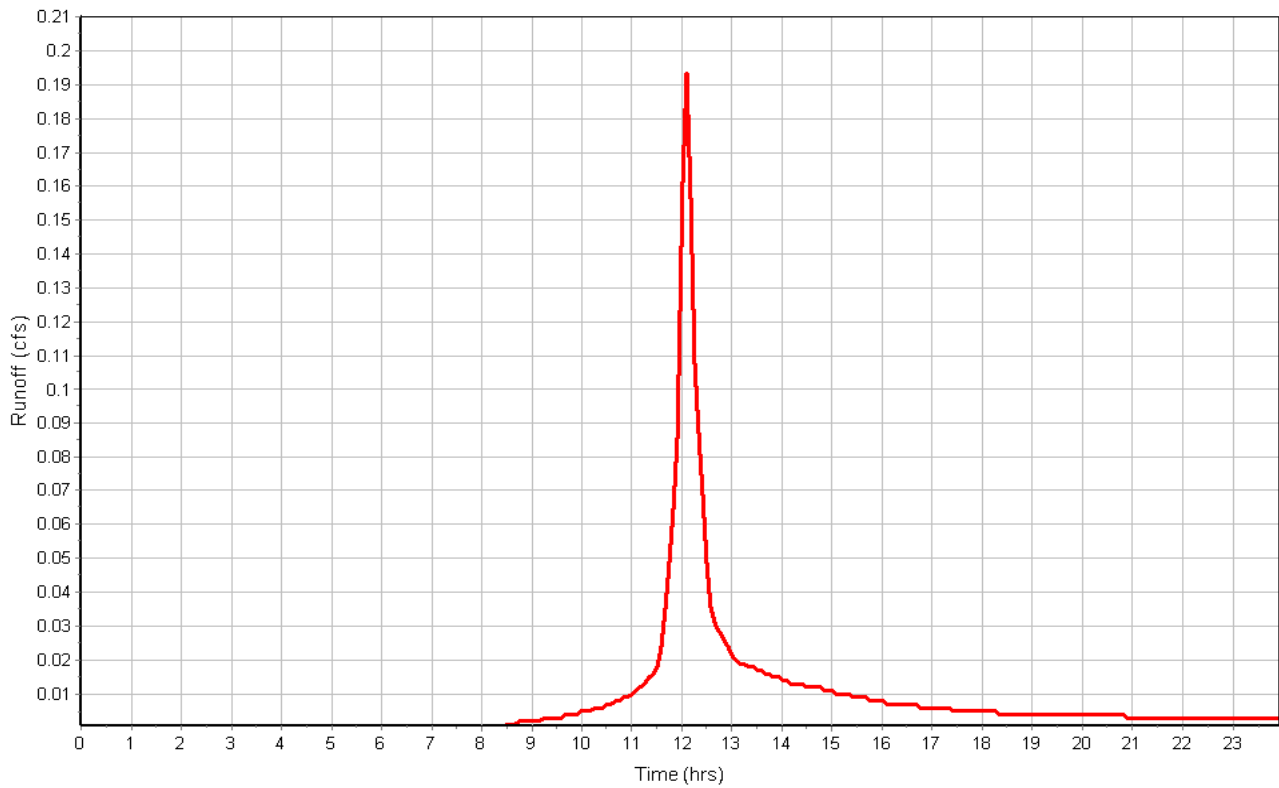

Subbasin : Sub-26

Input Data

Area (ac) 0.03
Weighted Curve Number 98.00
Average Slope (%) 0.0090
Flow Length (ft) 59.00
Rain Gage ID Rain Gage-01

Composite Curve Number

Soil/Surface Description	Area (acres)	Soil Group	Curve Number
Paved parking & roofs	0.03	A	98.00
Composite Area & Weighted CN	0.03		98.00

Time of Concentration

Flow Length (ft) 59.00
Slope (%)009
Computed TOC (min) 6.50

Subbasin Runoff Results

Total Rainfall (in) 5.12
Total Runoff (in) 4.85
Peak Runoff (cfs) 0.14
Weighted Curve Number 98.00
Time of Concentration (days hh:mm:ss) 0 00:06:30

Subbasin : Sub-26

Rainfall Intensity Graph

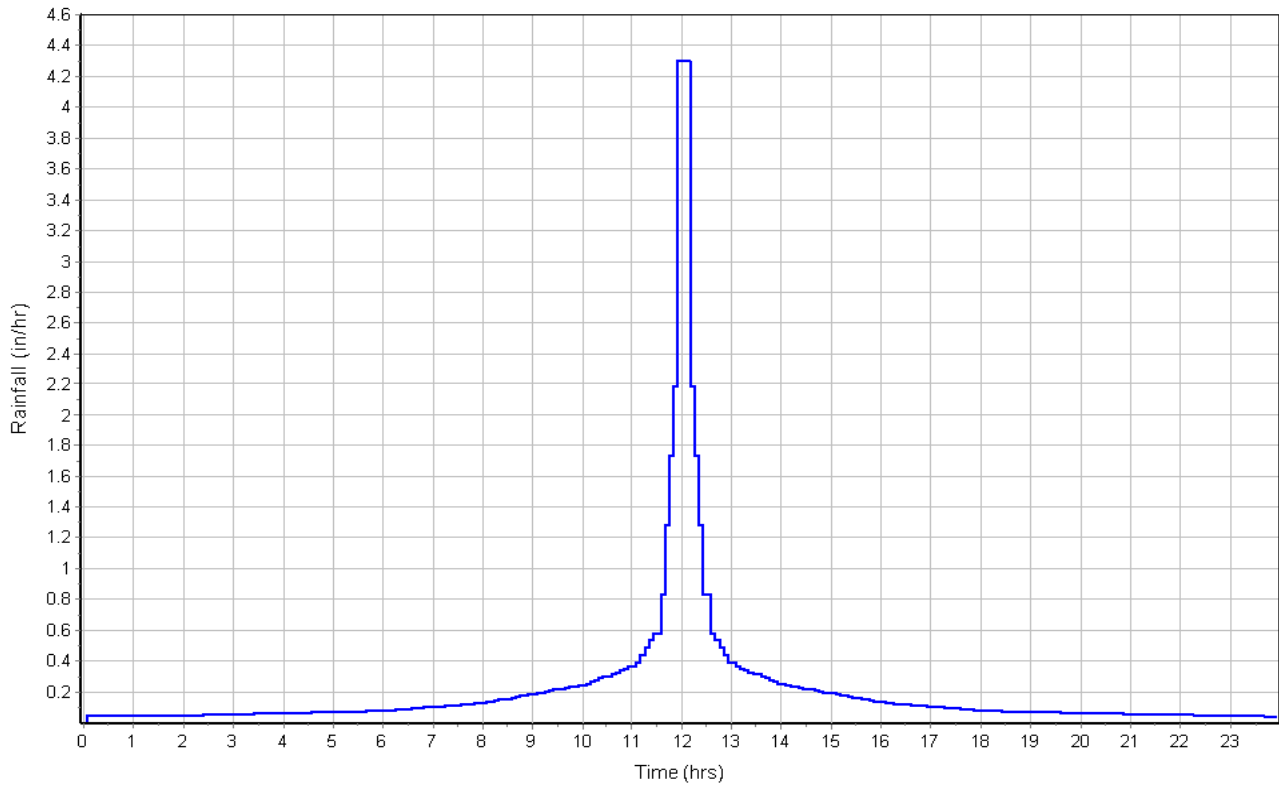

Runoff Hydrograph

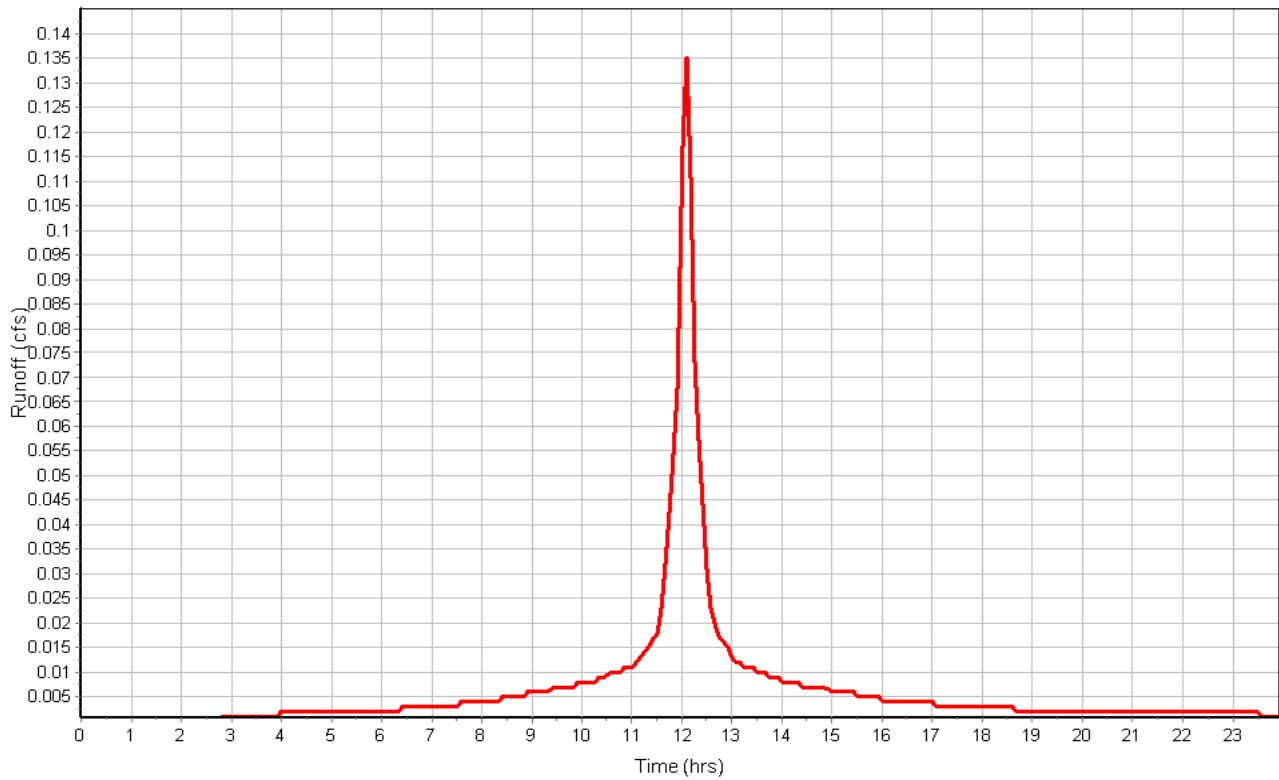

Subbasin : Sub-3b

Input Data

Area (ac) 0.51
Weighted Curve Number 86.17
Average Slope (%) 1.5000
Flow Length (ft) 160.00
Rain Gage ID Rain Gage-01

Composite Curve Number

Soil/Surface Description	Area (acres)	Soil Group	Curve Number
> 75% grass cover, Good	0.10	A	39.00
Paved parking & roofs	0.41	A	98.00
Composite Area & Weighted CN	0.51		86.17

Time of Concentration

Flow Length (ft) 160.00
Slope (%) 1.5
Computed TOC (min) 1.96

Subbasin Runoff Results

Total Rainfall (in) 5.12
Total Runoff (in) 3.60
Peak Runoff (cfs) 1.84
Weighted Curve Number 86.17
Time of Concentration (days hh:mm:ss) 0 00:01:58

Subbasin : Sub-3b

Rainfall Intensity Graph

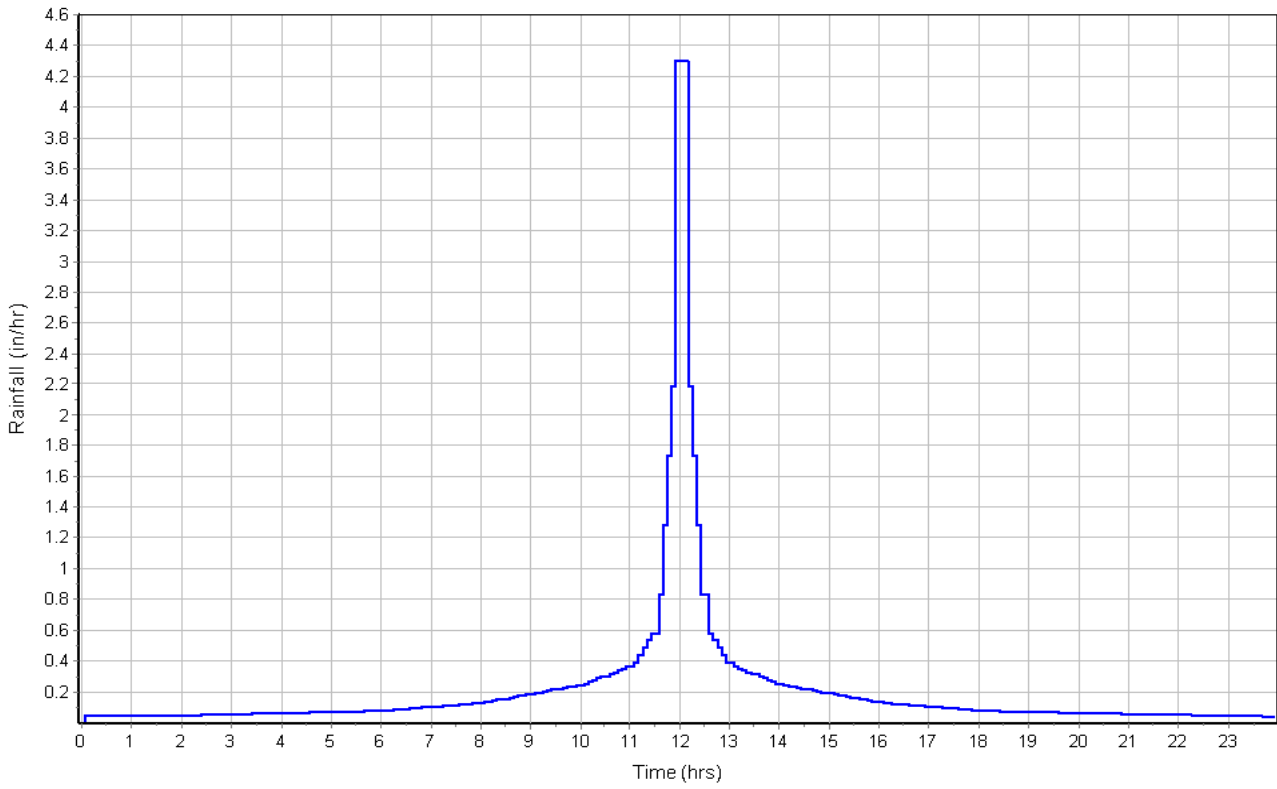

Runoff Hydrograph

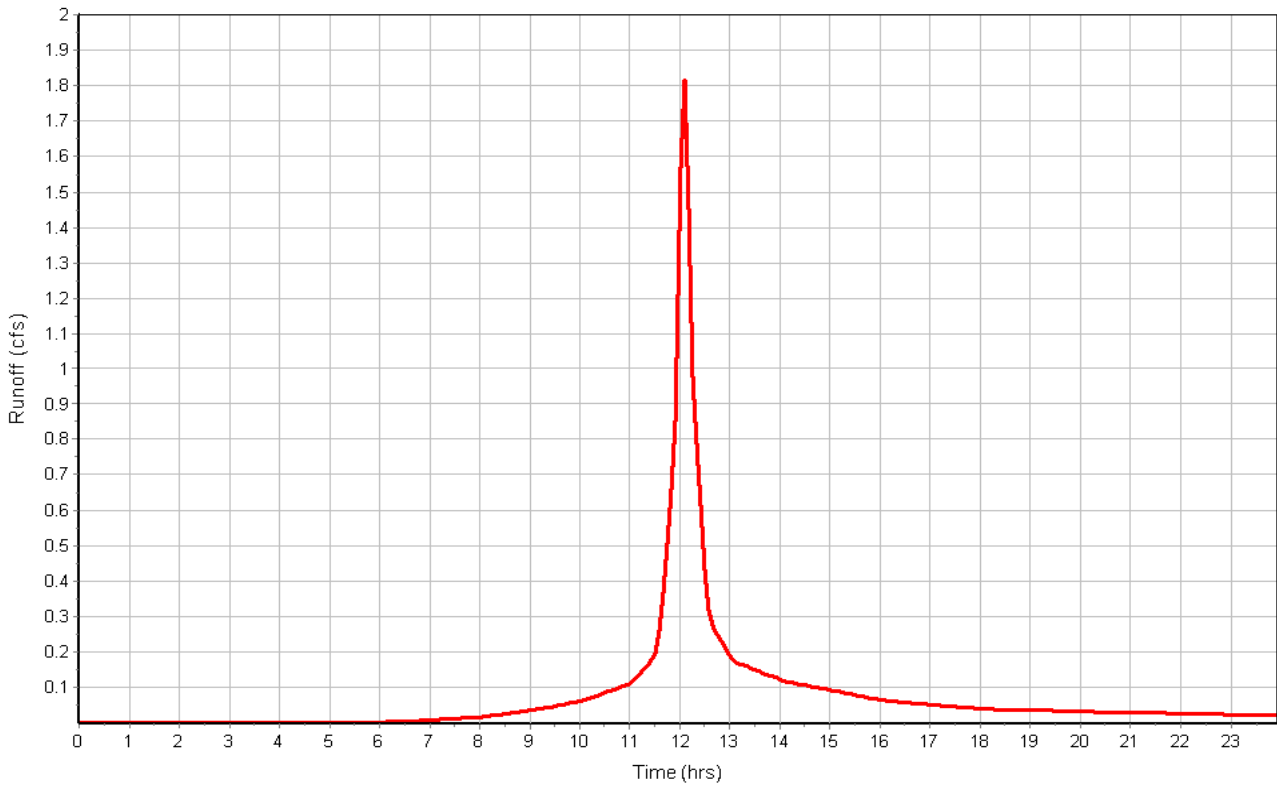

Junction Input

SN	Element ID	Invert Elevation (ft)	Ground/Rim (Max) Elevation (ft)	Ground/Rim (Max) Offset (ft)	Initial Water Elevation (ft)	Initial Water Depth (ft)	Surcharge Elevation (ft)	Surcharge Depth (ft)	Ponded Area (ft ²)	Minimum Pipe Cover (in)
1	DMH-10	130.91	137.43	6.52	133.50	2.59	137.42	-0.01	10.00	35.16
2	DMH-11	129.35	133.36	4.01	129.35	0.00	133.36	0.00	10.00	37.10
3	DMH-14	130.38	137.77	7.39	130.54	0.16	137.77	0.00	10.00	29.04
4	DMH-15	132.42	136.95	4.53	133.35	0.93	136.95	0.00	10.00	30.36
5	DMH-16	132.80	138.34	5.54	134.00	1.20	138.34	0.00	10.00	53.28
6	DMH-17	132.20	138.06	5.86	132.70	0.50	138.06	0.00	0.00	57.12
7	DMH-18	131.16	137.63	6.47	0.00	-131.16	137.63	0.00	0.00	58.44
8	DMH-19	130.30	136.60	6.30	0.00	-130.30	136.60	0.00	0.00	56.40
9	DMH-2	128.00	134.12	6.12	128.00	0.00	134.12	0.00	10.00	59.64
10	DMH-3	128.46	135.54	7.08	0.00	-128.46	135.54	0.00	0.00	65.76
11	DMH-4	128.93	136.00	7.07	131.90	2.97	136.00	0.00	10.00	25.20
12	DMH-5	128.70	135.20	6.50	128.70	0.00	135.20	0.00	10.00	54.84
13	DMH-6	131.00	134.90	3.90	131.00	0.00	134.90	0.00	10.00	24.12
14	DMH-8	129.45	137.46	8.01	132.68	3.23	137.46	0.00	10.00	30.84
15	DMH-9	131.64	136.95	5.31	132.62	0.98	137.17	0.22	10.00	38.52
16	Ex-DMH-2	132.04	138.10	6.06	132.50	0.46	138.10	0.00	10.00	53.52
17	OCS-1	130.45	134.27	3.82	130.45	0.00	134.27	0.00	10.00	55.32

Junction Results

SN Element ID	Peak Inflow	Peak Lateral Inflow	Max HGL Elevation Attained	Max HGL Depth Attained	Max Surcharge Depth Attained	Min Freeboard Attained	Average HGL Elevation Attained	Average HGL Depth Attained	Time of Max HGL Occurrence	Time of Peak Flooding Occurrence	Total Flooded Volume	Total Time Flooded
	(cfs)	(cfs)	(ft)	(ft)	(ft)	(ft)	(ft)	(ft)	(days hh:mm)	(days hh:mm)	(ac-in)	(min)
1 DMH-10	19.09	0.00	133.51	2.60	0.00	3.92	131.26	0.35	0 04:58	0 00:00	0.00	0.00
2 DMH-11	1.02	0.00	129.55	0.20	0.00	3.81	129.40	0.05	0 12:11	0 00:00	0.00	0.00
3 DMH-14	43.57	0.00	134.16	3.78	0.00	3.61	131.28	0.90	0 22:42	0 00:00	0.00	0.00
4 DMH-15	1.98	0.00	133.35	0.93	0.00	3.60	132.54	0.12	0 00:00	0 00:00	0.00	0.00
5 DMH-16	6.82	6.82	138.38	5.58	0.04	0.00	133.37	0.57	0 12:10	0 12:10	0.00	3.00
6 DMH-17	5.45	0.00	137.02	4.82	0.00	1.04	132.70	0.50	0 12:11	0 00:00	0.00	0.00
7 DMH-18	7.12	0.00	134.88	3.72	0.00	2.75	131.63	0.47	0 12:11	0 00:00	0.00	0.00
8 DMH-19	18.21	0.00	136.60	6.30	0.00	0.00	131.37	1.07	0 02:35	0 02:43	0.01	0.00
9 DMH-2	0.00	0.00	128.00	0.00	0.00	6.12	128.00	0.00	0 00:00	0 00:00	0.00	0.00
10 DMH-3	85.68	0.00	135.54	7.08	0.00	0.00	131.32	2.86	0 00:12	0 23:05	0.64	1.00
11 DMH-4	220.50	0.00	145.99	17.06	9.99	0.00	131.29	2.36	0 00:24	0 00:24	11.71	15.00
12 DMH-5	180.47	0.00	140.89	12.19	5.69	0.00	131.26	2.56	0 22:41	0 03:19	3.23	8.00
13 DMH-6	72.16	0.00	134.90	3.90	0.00	0.00	131.22	0.22	0 00:43	0 00:00	0.00	0.00
14 DMH-8	90.20	0.00	137.46	8.01	0.00	0.00	131.29	1.84	0 22:41	0 00:00	0.00	0.00
15 DMH-9	8.19	0.00	132.96	1.32	0.00	3.99	131.80	0.16	0 00:00	0 00:00	0.00	0.00
16 Ex-DMH-2	7.14	0.00	136.23	4.19	0.00	1.87	132.49	0.45	0 12:11	0 00:00	0.00	0.00
17 OCS-1	0.00	0.00	130.45	0.00	0.00	3.82	130.45	0.00	0 00:00	0 00:00	0.00	0.00

Pipe Input

SN	Element ID	Length (ft)	Inlet Invert Elevation (ft)	Inlet Invert Offset (ft)	Outlet Invert Elevation (ft)	Outlet Invert Offset (ft)	Total Drop (ft)	Average Pipe Slope (%)	Pipe Shape	Pipe Diameter or Height (in)	Pipe Width (in)	Manning's Roughness	Entrance Losses	Exit/Bend Losses	Additional Losses	Initial Flap Flow Gate	No. of Barrels
1	Link-47	60.55	128.93	0.00	128.63	-0.07	0.30	0.5000	CIRCULAR	24.000	24.000	0.0130	0.5000	0.5000	0.0000	0.00 No	1
2	Link-48(P-4)	39.48	132.92	0.00	132.72	0.10	0.20	0.5100	CIRCULAR	12.000	12.000	0.0130	0.5000	0.5000	0.0000	0.00 No	1
3	P-1	36.03	133.47	-0.03	133.35	0.93	0.12	0.3300	CIRCULAR	12.000	12.000	0.0130	0.5000	0.5000	0.0000	0.00 No	1
4	P-10	12.78	133.56	0.00	133.50	2.59	0.06	0.4700	CIRCULAR	12.000	12.000	0.0130	0.5000	0.5000	0.0000	0.00 No	1
5	P-11	26.24	132.75	-0.09	132.62	0.98	0.13	0.5000	CIRCULAR	12.000	12.000	0.0130	0.5000	0.5000	0.0000	0.00 No	1
6	P-12	13.07	133.96	1.21	133.89	4.44	0.07	0.5400	CIRCULAR	12.000	12.000	0.0130	0.5000	0.5000	0.0000	0.00 No	1
7	P-13	9.55	133.00	1.00	132.90	3.97	0.10	1.0500	CIRCULAR	12.000	12.000	0.0130	0.5000	0.5000	0.0000	0.00 No	1
8	P-14	6.19	128.27	0.01	128.27	-1.08	0.00	0.0000	CIRCULAR	24.000	24.000	0.0130	0.5000	0.5000	0.0000	0.00 No	1
9	P-15	93.60	127.66	-2.79	127.15	-0.85	0.51	0.5400	CIRCULAR	24.000	24.000	0.0130	0.5000	0.5000	0.0000	0.00 No	1
10	P-16	126.08	128.53	-0.17	128.35	-2.65	0.18	0.1400	CIRCULAR	24.000	24.000	0.0130	0.5000	0.5000	0.0000	0.00 No	1
11	P-2	19.65	133.45	0.83	133.35	0.93	0.10	0.5100	CIRCULAR	12.000	12.000	0.0130	0.5000	0.5000	0.0000	0.00 No	1
12	P-20	34.45	127.10	-0.90	127.00	0.00	0.10	0.2900	CIRCULAR	24.000	24.000	0.0130	0.5000	0.5000	0.0000	0.00 No	1
13	P-21	3.92	128.27	-2.73	128.27	0.01	0.00	0.0000	CIRCULAR	24.000	24.000	0.0130	0.5000	0.5000	0.0000	0.00 No	1
14	P-23	34.86	133.07	0.00	132.90	0.10	0.17	0.4900	CIRCULAR	12.000	12.000	0.0130	0.5000	0.5000	0.0000	0.00 No	1
15	P-24	6.76	132.34	0.00	132.30	0.10	0.04	0.5900	CIRCULAR	12.000	12.000	0.0150	0.5000	0.5000	0.0000	0.00 No	1
16	P-25	67.17	132.78	0.00	132.44	0.10	0.34	0.5100	CIRCULAR	12.000	12.000	0.0130	0.5000	0.5000	0.0000	0.00 No	1
17	P-30	8.44	134.40	134.40	134.35	3.97	0.05	0.5900	CIRCULAR	12.000	12.000	0.0130	0.5000	0.5000	0.0000	0.00 No	1
18	P-34	165.96	130.38	0.00	129.55	0.10	0.83	0.5000	CIRCULAR	24.000	24.000	0.0130	0.5000	0.5000	0.0000	0.00 No	1
19	P-35	86.67	130.91	0.00	130.48	0.10	0.43	0.5000	CIRCULAR	24.000	24.000	0.0130	0.5000	0.5000	0.0000	0.00 No	1
20	P-36	83.65	129.45	0.00	129.03	0.10	0.42	0.5000	CIRCULAR	24.000	24.000	0.0130	0.5000	0.5000	0.0000	0.00 No	1
21	P-37	126.05	131.64	0.00	131.01	0.10	0.63	0.5000	CIRCULAR	24.000	24.000	0.0130	0.5000	0.5000	0.0000	0.00 No	1
22	P-38	134.96	132.42	0.00	131.74	0.10	0.68	0.5000	CIRCULAR	24.000	24.000	0.0130	0.5000	0.5000	0.0000	0.00 No	1
23	P-39	100.55	132.80	0.00	132.30	0.10	0.50	0.5000	CIRCULAR	12.000	12.000	0.0130	0.5000	0.5000	0.0000	0.00 No	1
24	P-4	39.48	133.73	0.81	133.55	0.93	0.18	0.4600	CIRCULAR	12.000	12.000	0.0130	0.5000	0.5000	0.0000	0.00 No	1
25	P-40	155.37	132.04	0.00	131.26	0.10	0.78	0.5000	CIRCULAR	18.000	18.000	0.0150	0.5000	0.5000	0.0000	0.00 No	1
26	P-41	153.22	131.16	0.00	130.40	0.10	0.76	0.5000	CIRCULAR	18.000	18.000	0.0150	0.5000	0.5000	0.0000	0.00 No	1
27	P-42	90.24	130.30	0.00	128.56	0.10	1.74	1.9300	CIRCULAR	18.000	18.000	0.0150	0.5000	0.5000	0.0000	0.00 No	1
28	P-43	19.19	128.46	0.00	128.36	-2.64	0.10	0.5200	CIRCULAR	18.000	18.000	0.0150	0.5000	0.5000	0.0000	0.00 No	1
29	P-44	10.22	132.20	0.00	132.14	0.10	0.06	0.5900	CIRCULAR	12.000	12.000	0.0130	0.5000	0.5000	0.0000	0.00 No	1
30	P-45	59.01	133.00	0.00	132.70	0.10	0.30	0.5100	CIRCULAR	18.000	18.000	0.0130	0.5000	0.5000	0.0000	0.00 No	1
31	P-46	92.40	132.60	0.00	132.14	0.10	0.46	0.5000	CIRCULAR	18.000	18.000	0.0130	0.5000	0.5000	0.0000	0.00 No	1
32	P-5	101.87	129.71	0.00	129.20	-0.15	0.51	0.5000	CIRCULAR	12.000	12.000	0.0130	0.5000	0.5000	0.0000	0.00 No	1
33	P-6	20.36	132.00	0.89	131.89	0.89	0.11	0.5400	CIRCULAR	12.000	12.000	0.0130	0.5000	0.5000	0.0000	0.00 No	1
34	P-8	60.55	128.70	-0.23	128.53	-0.17	0.17	0.2800	CIRCULAR	24.000	24.000	0.0130	0.5000	0.5000	0.0000	0.00 No	1

Pipe Results

SN Element ID	Peak Flow (cfs)	Time of Peak Flow Occurrence (days hh:mm)	Design Flow Capacity (cfs)	Peak Flow/Design Flow Ratio	Peak Flow Velocity (ft/sec)	Travel Time (min)	Peak Flow Depth (ft)	Peak Flow Depth/Total Depth Ratio	Total Time Surcharged (min)	Froude Number	Reported Condition
1 Link-47	104.15	0 00:24	13.94	7.47	42.96	0.02	2.00	1.00	1267.00		SURCHARGED
2 Link-48(P-4)	1.01	0 06:23	2.54	0.40	2.18	0.30	0.90	0.90	0.00		Calculated
3 P-1	1.67	0 12:10	2.30	0.72	3.16	0.19	0.63	0.64	0.00		Calculated
4 P-10	0.40	0 12:10	2.44	0.16	2.11	0.10	0.29	0.29	0.00		Calculated
5 P-11	0.89	0 12:10	3.26	0.27	3.17	0.14	0.38	0.39	0.00		Calculated
6 P-12	60.38	0 20:49	2.61	23.16	50.00	0.00	0.90	1.00	3.00		SURCHARGED
7 P-13	47.14	0 20:48	3.65	12.93	50.00	0.00	0.96	1.00	29.00		SURCHARGED
8 P-14	1.02	0 12:11	94.59	0.01	7.69	0.01	0.17	0.09	0.00		Calculated
9 P-15	0.00	0 00:00	36.60	0.00	0.00		0.00	0.00	0.00		Calculated
10 P-16	61.91	0 05:35	30.55	2.03	27.22	0.08	1.73	1.00	2.00		SURCHARGED
11 P-2	0.32	0 12:10	2.54	0.13	6.72	0.05	0.25	0.25	0.00		Calculated
12 P-20	0.00	0 00:00	38.54	0.00	0.00		0.00	0.00	0.00		Calculated
13 P-21	1392.37	0 00:43	188.79	7.38	50.00	0.00	0.95	1.00	0.00		> CAPACITY
14 P-23	2.48	0 12:10	2.49	1.00	3.15	0.18	1.00	1.00	33.00		SURCHARGED
15 P-24	0.77	0 12:16	2.38	0.32	1.68	0.07	1.00	1.00	33.00		SURCHARGED
16 P-25	0.91	0 12:21	2.53	0.36	1.16	0.97	1.00	1.00	25.00		SURCHARGED
17 P-30	0.00	0 00:00	2.74	0.00	0.00		0.00	0.00	0.00		Calculated
18 P-34	43.57	0 22:41	16.00	2.72	18.63	0.15	2.00	1.00	9.00		SURCHARGED
19 P-35	19.09	0 22:42	15.93	1.20	6.75	0.21	1.83	1.00	1.00		SURCHARGED
20 P-36	72.44	0 23:15	16.03	4.52	23.23	0.06	2.00	1.00	172.00		SURCHARGED
21 P-37	8.15	0 22:05	15.99	0.51	3.64	0.58	1.24	0.77	0.00		Calculated
22 P-38	2.92	0 00:00	16.06	0.18	3.30	0.68	0.49	0.46	0.00		Calculated
23 P-39	5.09	0 12:03	2.51	2.03	6.48	0.26	1.00	1.00	34.00		SURCHARGED
24 P-4	0.52	0 06:23	2.41	0.22	6.20	0.11	0.09	0.16	0.00		Calculated
25 P-40	7.12	0 12:10	6.45	1.10	4.03	0.64	1.50	1.00	24.00		SURCHARGED
26 P-41	7.12	0 12:10	6.41	1.11	5.01	0.51	1.50	1.00	32.00		SURCHARGED
27 P-42	18.21	0 22:05	12.64	1.44	10.31	0.15	1.50	1.00	57.00		SURCHARGED
28 P-43	85.68	0 23:05	33.12	2.59	48.48	0.01	1.46	1.00	5.00		SURCHARGED
29 P-44	5.35	0 12:03	2.73	1.96	6.81	0.03	1.00	1.00	30.00		SURCHARGED
30 P-45	2.07	0 12:05	7.49	0.28	1.63	0.60	1.50	1.00	16.00		SURCHARGED
31 P-46	2.62	0 12:08	7.41	0.35	1.54	1.00	1.50	1.00	19.00		SURCHARGED
32 P-5	1.02	0 12:11	2.12	0.48	3.97	0.43	0.35	0.36	0.00		Calculated
33 P-6	18.70	0 02:35	2.62	7.14	47.37	0.01	0.87	1.00	5.00		SURCHARGED
34 P-8	104.15	0 00:24	13.94	7.47	42.96	0.02	2.00	1.00	1267.00		SURCHARGED

Inlet Input

SN Element ID	Inlet Manufacturer	Manufacturer Part Number	Inlet Location	Number of Inlets	Catchbasin Invert Elevation (ft)	Max (Rim) Elevation (ft)	Inlet Depth (ft)	Initial Water Elevation (ft)	Initial Water Depth (ft)	Ponded Area (ft ²)	Grate Clogging Factor (%)
1 CB-1	FHWA HEC-22 GENERIC	N/A	On Sag	1	133.50	135.47	1.97	133.50	0.00	200.00	0.00
2 CB-10	FHWA HEC-22 GENERIC	N/A	On Sag	1	132.92	136.73	3.81	0.00	0.00	10.00	0.00
3 CB-12	FHWA HEC-22 GENERIC	N/A	On Sag	1	132.34	137.96	5.62	132.58	0.24	200.00	0.00
4 CB-13	FHWA HEC-22 GENERIC	N/A	On Sag	1	132.62	136.30	3.68	133.52	0.90	200.00	0.00
5 CB-14	FHWA HEC-22 GENERIC	N/A	On Sag	1	132.78	137.97	5.19	0.00	0.00	10.00	0.00
6 CB-15	FHWA HEC-22 GENERIC	N/A	On Sag	1	0.00	137.40	137.40	0.00	0.00	10.00	0.00
7 CB-16	FHWA HEC-22 GENERIC	N/A	On Sag	1	133.00	136.72	3.72	132.45	-0.55	200.00	0.00
8 CB-17	FHWA HEC-22 GENERIC	N/A	On Sag	1	132.60	136.03	3.43	131.82	-0.78	200.00	0.00
9 CB-2	FHWA HEC-22 GENERIC	N/A	On Sag	1	132.00	136.00	4.00	132.00	0.00	200.00	0.00
10 CB-3	FHWA HEC-22 GENERIC	N/A	On Sag	1	131.11	135.36	4.25	131.11	0.00	200.00	0.00
11 CB-4	FHWA HEC-22 GENERIC	N/A	On Sag	1	129.71	132.97	3.26	129.71	0.00	200.00	0.00
12 CB-5	FHWA HEC-22 GENERIC	N/A	On Sag	1	132.84	136.84	4.00	132.84	0.00	200.00	0.00
13 CB-7	FHWA HEC-22 GENERIC	N/A	On Sag	1	133.56	137.23	3.67	133.56	0.00	200.00	0.00
14 CB-8	FHWA HEC-22 GENERIC	N/A	On Sag	1	132.75	136.96	4.21	132.75	0.00	200.00	0.00
15 CB-9	FHWA HEC-22 GENERIC	N/A	On Sag	1	133.07	138.05	4.98	132.80	-0.27	200.00	0.00

Roadway & Gutter Input

SN Element ID	Roadway Longitudinal Slope (ft/ft)	Roadway Cross Slope (ft/ft)	Roadway Manning's Roughness	Gutter Cross Slope (ft/ft)	Gutter Width (ft)	Gutter Depression (in)	Allowable Spread (ft)
1 CB-1	N/A	0.0200	0.0160	0.0620	2.00	0.0656	7.00
2 CB-10	N/A	0.0200	0.0160	0.0620	2.00	0.0656	7.00
3 CB-12	N/A	0.0200	0.0160	0.0620	2.00	0.0656	7.00
4 CB-13	N/A	0.0200	0.0160	0.0620	2.00	0.0656	7.00
5 CB-14	N/A	0.0200	0.0160	0.0620	2.00	0.0656	7.00
6 CB-15	N/A	0.0200	0.0160	0.0620	2.00	0.0656	7.00
7 CB-16	N/A	0.0200	0.0160	0.0620	2.00	0.0656	7.00
8 CB-17	N/A	0.0200	0.0160	0.0620	2.00	0.0656	7.00
9 CB-2	N/A	0.0200	0.0160	0.0620	2.00	0.0656	7.00
10 CB-3	N/A	0.0200	0.0160	0.0620	2.00	0.0656	7.00
11 CB-4	N/A	0.0200	0.0160	0.0620	2.00	0.0656	7.00
12 CB-5	N/A	0.0200	0.0160	0.0620	2.00	0.0656	7.00
13 CB-7	N/A	0.0200	0.0160	0.0620	2.00	0.0656	7.00
14 CB-8	N/A	0.0200	0.0160	0.0620	2.00	0.0656	7.00
15 CB-9	N/A	0.0200	0.0160	0.0620	2.00	0.0656	7.00

Inlet Results

SN Element ID	Peak Flow	Peak Lateral Inflow	Peak Flow Intercepted	Peak Flow Bypassing Inlet	Inlet Efficiency during Peak	Max Gutter Spread during Peak	Max Gutter Water Elev. during Peak	Max Gutter Water Depth during Peak	Time of Max Depth Occurrence	Total Flooded Volume	Total Time Flooded
	(cfs)	(cfs)	(cfs)	(cfs)	(%)	(ft)	(ft)	(ft)	(days hh:mm)	(ac-in)	(min)
1 CB-1	1.68	1.68	N/A	N/A	N/A	9.07	135.90	0.43	0 12:10	0.00	0.00
2 CB-10	0.24	0.24	N/A	N/A	N/A	1.49	136.82	0.09	0 12:10	0.00	0.00
3 CB-12	0.14	0.14	N/A	N/A	N/A	0.83	138.01	0.05	0 12:11	0.00	0.00
4 CB-13	0.08	0.08	N/A	N/A	N/A	0.51	136.33	0.03	0 12:10	0.00	0.00
5 CB-14	0.19	0.19	N/A	N/A	N/A	1.19	138.04	0.07	0 12:03	0.01	3.00
6 CB-15	0.00	0.00	N/A	N/A	N/A	0.00	137.40	0.00	0 00:00	0.00	0.00
7 CB-16	0.70	0.70	N/A	N/A	N/A	4.33	136.97	0.25	0 12:03	0.00	2.00
8 CB-17	1.82	1.82	N/A	N/A	N/A	9.66	136.47	0.44	0 12:03	0.01	5.00
9 CB-2	0.36	0.36	N/A	N/A	N/A	2.25	136.13	0.13	0 00:12	1.50	17.00
10 CB-3	0.59	0.59	N/A	N/A	N/A	3.63	135.57	0.21	0 00:12	0.07	4.00
11 CB-4	1.04	1.04	N/A	N/A	N/A	6.32	133.34	0.37	0 12:10	0.00	0.00
12 CB-5	0.91	0.91	N/A	N/A	N/A	5.61	137.17	0.33	0 12:10	0.00	0.00
13 CB-7	0.40	0.40	N/A	N/A	N/A	2.50	137.38	0.15	0 12:10	0.00	0.00
14 CB-8	0.29	0.29	N/A	N/A	N/A	1.78	137.06	0.10	0 03:40	1.09	6.00
15 CB-9	0.13	0.13	N/A	N/A	N/A	0.77	138.09	0.04	0 12:03	0.40	15.00

Profile Plot
Spofford Pond School

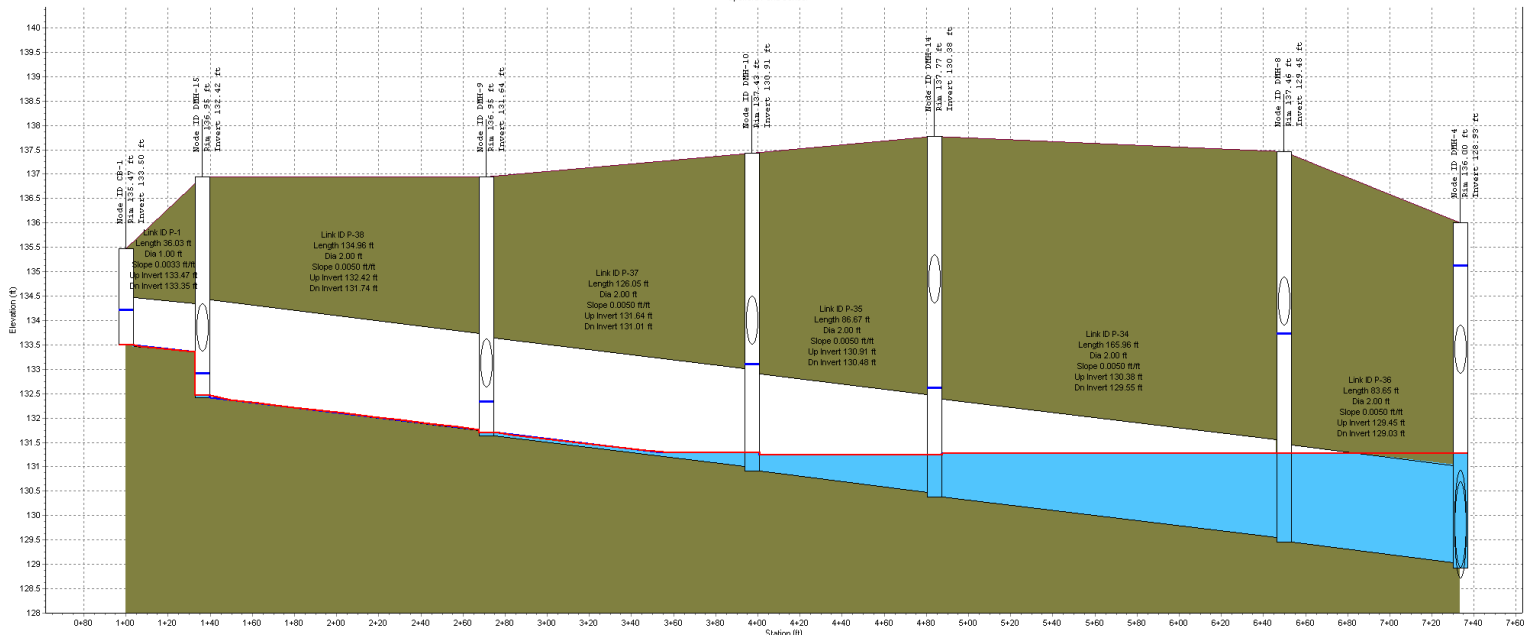

Node ID	CB-1	DMH-15	DMH-9	DMH-10	DMH-14	DMH-8	DMH-4
Rim (ft)	135.47	135.95	136.95	137.43	137.77	137.46	136.00
Invert (ft)	133.50	132.42	131.84	130.91	130.38	129.45	128.93
Min Pipe Cover (ft)		2.53	3.21	2.93	2.42	2.57	2.10
Max HGL (ft)	134.22	133.35	132.96	133.51	134.16	137.46	145.99
Link ID	P-1		P-38	P-37	P-35	P-34	P-36
Length (ft)	36.03		134.96	126.05	86.67	165.96	83.65
Dia (ft)	1.00		2.00	2.00	2.00	2.00	2.00
Slope (ft/ft)	0.0033		0.0050	0.0050	0.0050	0.0050	0.0050
Up Invert (ft)	133.47		132.42	131.84	130.91	130.38	129.45
Dn Invert (ft)	133.35		131.74	131.01	130.48	129.95	129.03
Max O (ft)	1.67		2.92	8.15	19.09	43.57	72.44
Max Vel (ft/s)	3.16		3.30	3.64	6.75	18.63	23.23
Max Depth (ft)	0.63		0.49	1.24	1.63	2.00	2.00

Profile Plot
Spofford Pond School

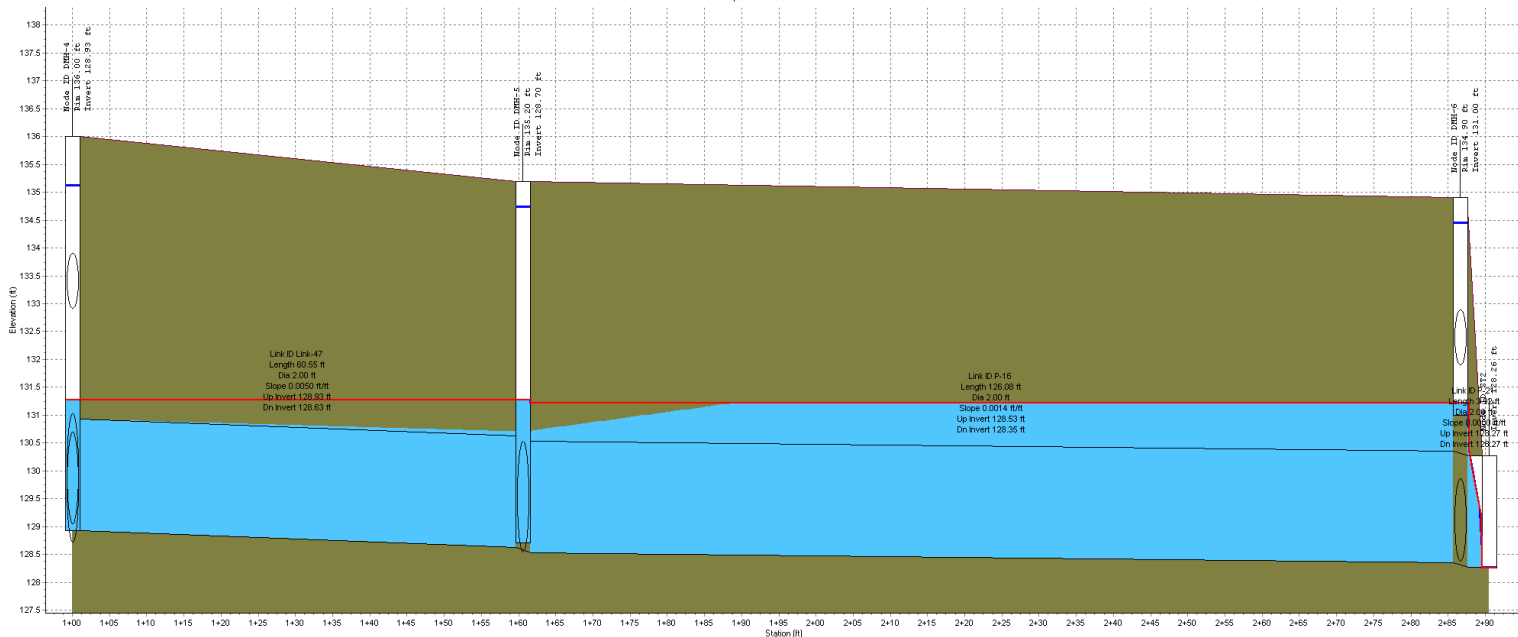

Node ID	DMH-4	DMH-5	DMH-6	ST2
Rim (ft)	136.00	135.20	134.90	
Invert (ft)	128.93	128.70	131.00	128.26
Min Pipe Cover (ft)	2.10	4.57	2.01	
Max HGL (ft)	145.99	140.89	134.90	128.26
Link ID	Link-47		P-16	P-21
Length (ft)	60.55		128.08	2.92
Dia (ft)	2.00		2.00	2.00
Slope (ft/ft)	0.0050		0.0014	0.0000
Up Invert (ft)	128.93		128.53	128.27
Dn Invert (ft)	128.63		128.35	128.27
Max O (cfs)	42.95		61.91	152.37
Max Vel (ft/s)			27.22	50.00
Max Depth (ft)	2.00		1.73	0.95

Profile Plot
Spofford Pond School

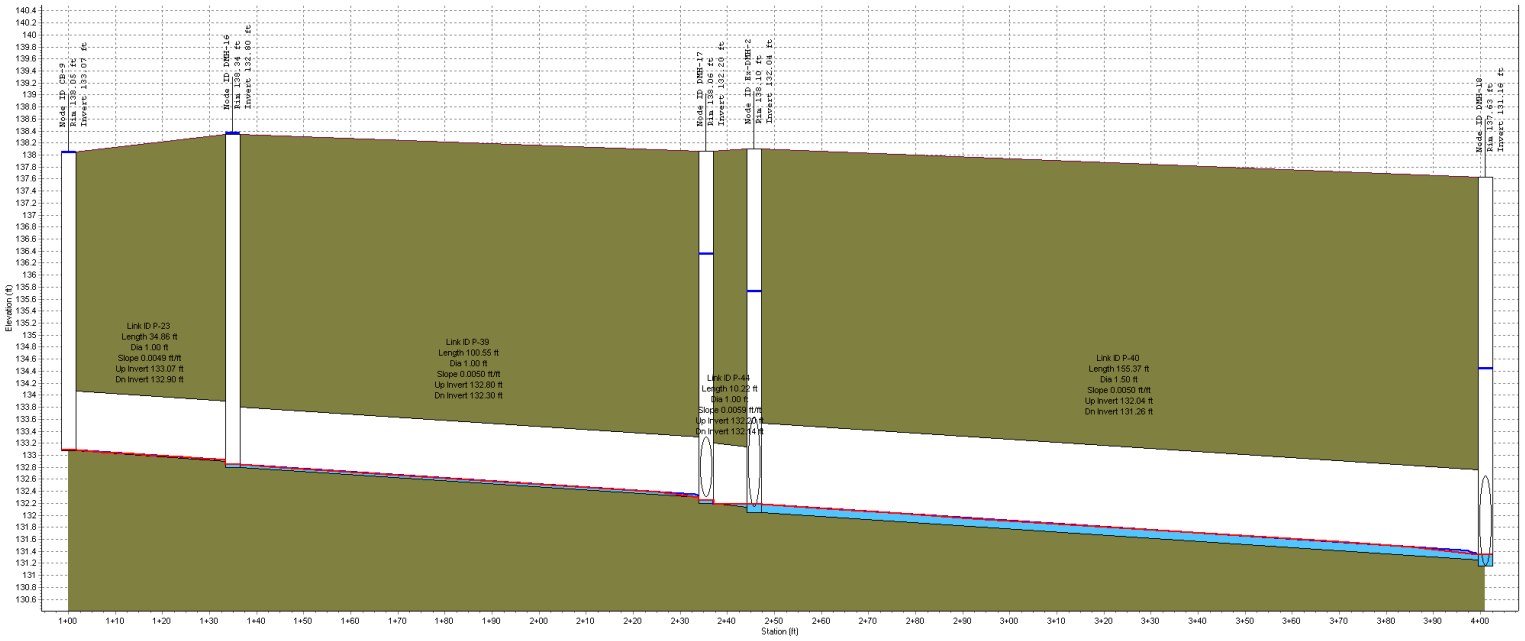

Node ID	CB-9	DMH-16	DMH-17	Ex-DMH-2	DMH-18
Rim (ft)	133.05	133.34	136.06	136.10	137.63
Invert (ft)	133.07	132.60	132.20	132.04	131.16
Min Pipe Cover (ft)		4.44	4.76	4.46	4.87
Max HGL (ft)	138.05	138.38	137.02	136.23	134.88
Link ID	P-23		P-44		P-40
Length (ft)	34.86	100.55	10.22	155.37	
Diag (ft)	1.00	1.00	1.00	1.50	
Slope (ft/ft)	0.0049	0.0050	0.0059	0.0050	
Up Invert (ft)	133.07	132.80	132.20	132.04	
Dn Invert (ft)	132.90	132.30	132.14	131.26	
Max Q (cfs)	2.48	5.09	5.35	7.12	
Max Vel (ft/s)	3.15	6.48	6.81	4.03	
Max Depth (ft)	1.00	1.00	1.00	1.50	

Profile Plot
Spofford Pond School

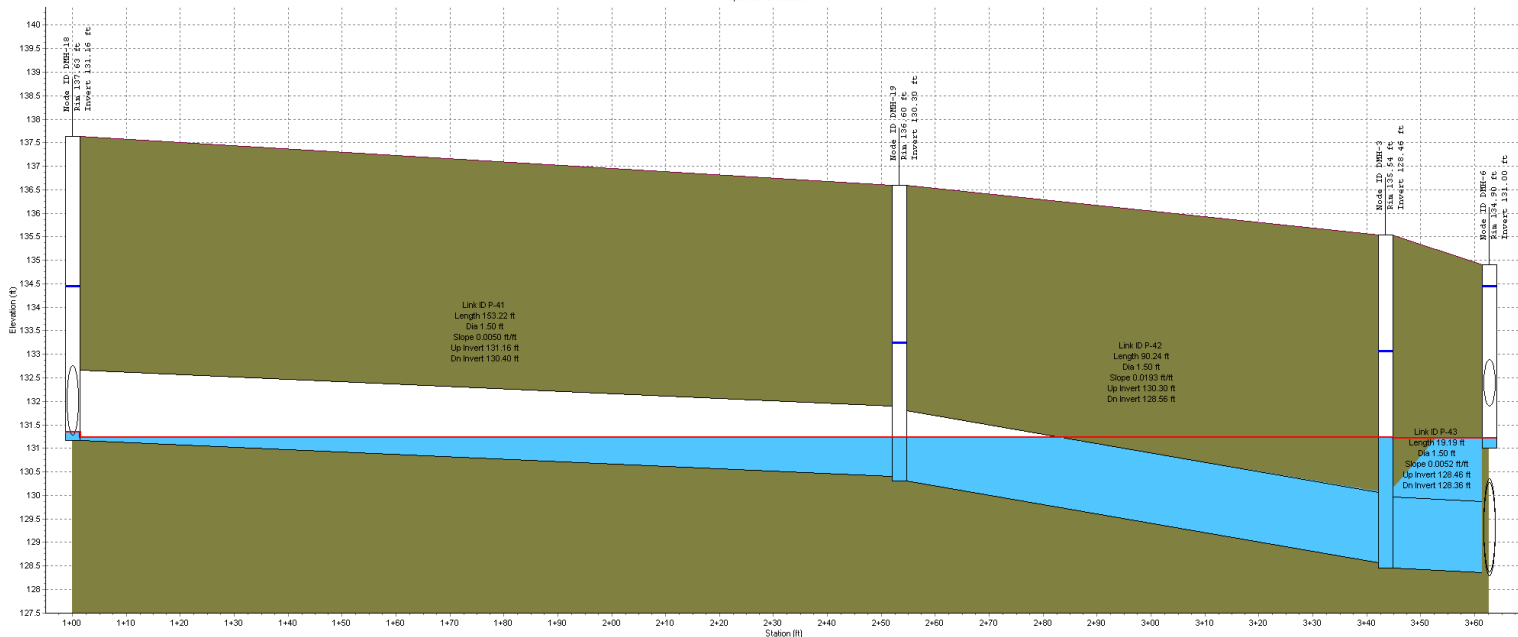

Node ID:	DMH-18		DMH-19		DMH-3	DMH-6
Rim (ft)	137.63		136.60		135.54	134.90
Invert (ft)	131.16		130.30		128.46	131.00
Min Pipe Cover (ft)	4.87		4.70		5.48	2.01
Max HGL (ft)	134.80		136.60		135.54	134.90
Link ID:	P-41		P-42		P-43	
Length (ft)	152.22		80.24		18.19	
Dia (ft)	1.50		1.50		1.50	
Slope (ft/ft)	0.0050		0.0193		0.0052	
Up Invert (ft)	131.16		130.30		128.46	
Dn Invert (ft)	130.40		128.56		128.36	
Max Q (cfs)	7.12		18.21		85.88	
Max Vel (ft/s)	5.01		10.31		43.49	
Max Depth (ft)	1.50		1.50		1.46	

Profile Plot
Spofford Pond School

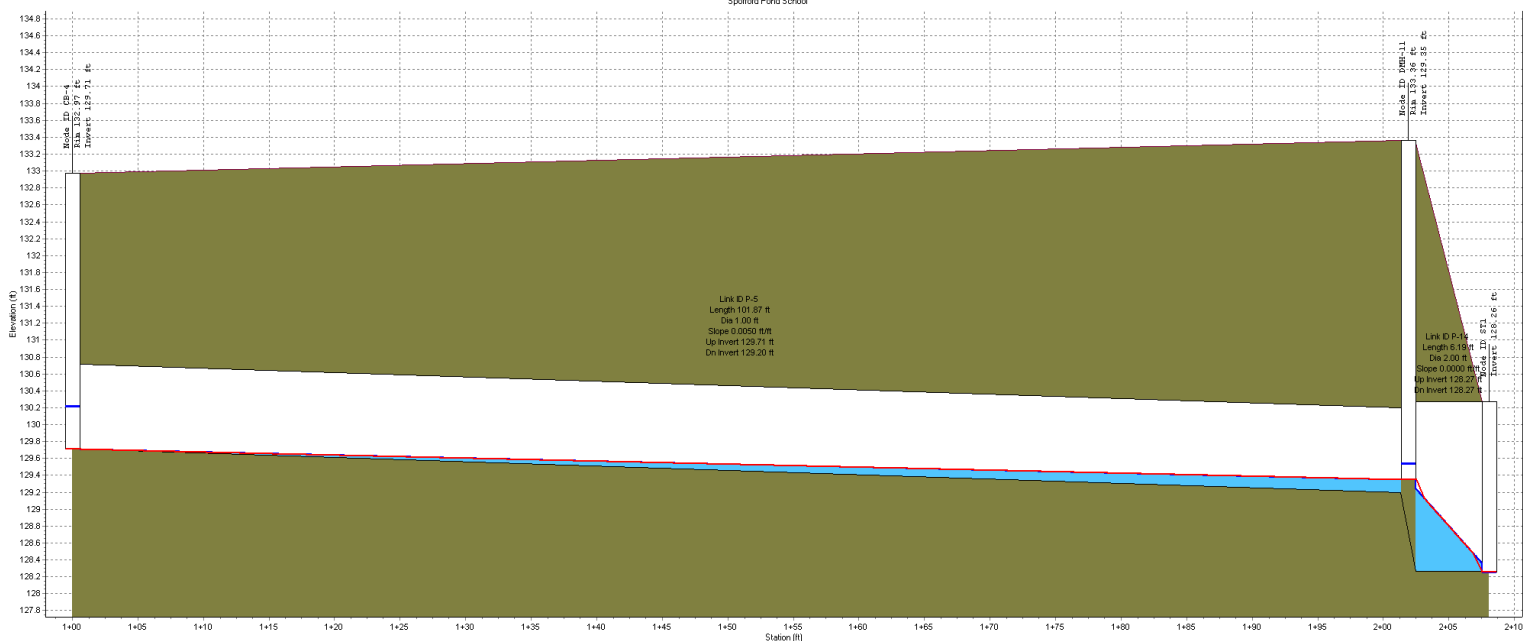

Node ID:	CB-4		DMH-11	ST1
Rim (ft):	132.97		133.38	
Invert (ft):	129.71		129.35	128.26
Min Pipe Cover (ft):			3.09	
Max HGL (ft):	130.22		129.55	128.26
Link ID:		P-5		P-14
Length (ft):		101.87		6.19
Dia (ft):		1.00		2.00
Slope (ft/ft):		0.0050		0.0000
Up Invert (ft):		129.71		128.27
Dn Invert (ft):		129.20		128.27
Max Q (cfs):		3.97		1.02
Max Vel (ft/s):		3.97		7.58
Max Depth (ft):		0.36		0.17

Profile Plot
Spofford Pond School

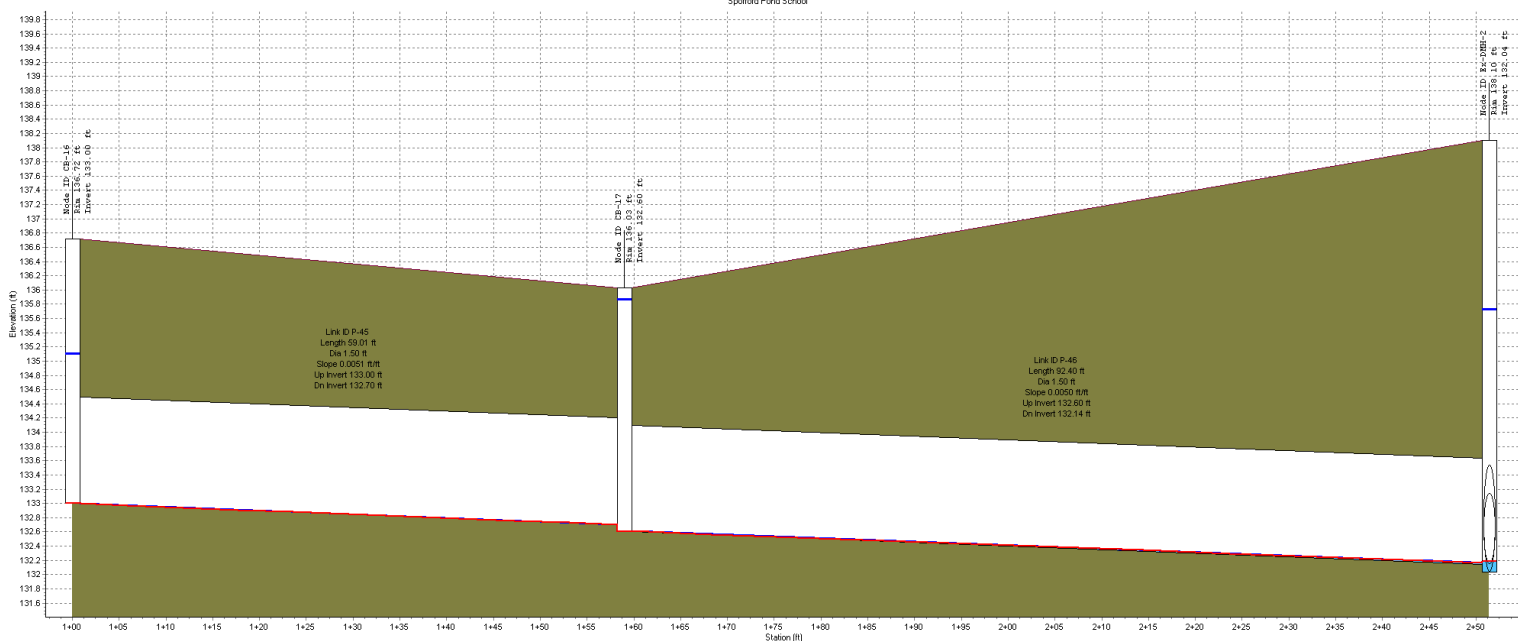

Node ID	CB-15	CB-17	Ex-DMR-2
Rim (ft)	136.72	135.03	136.10
Invert (ft)	133.00	132.60	132.04
Min Pipe Cover (ft)			4.46
Max HGL (ft)	135.11	135.97	136.23
Link ID	P-45		P-46
Length (ft)	59.01		92.40
Dia (ft)	1.50		1.50
Slope (ft/ft)	0.0051		0.0050
Up Invert (ft)	133.00		132.60
Dn Invert (ft)	132.70		132.14
Max Q (cfs)	2.07		2.62
Max Vel (ft/s)	1.63		1.54
Max Depth (ft)	1.50		1.50

Profile Plot
Spofford Pond School

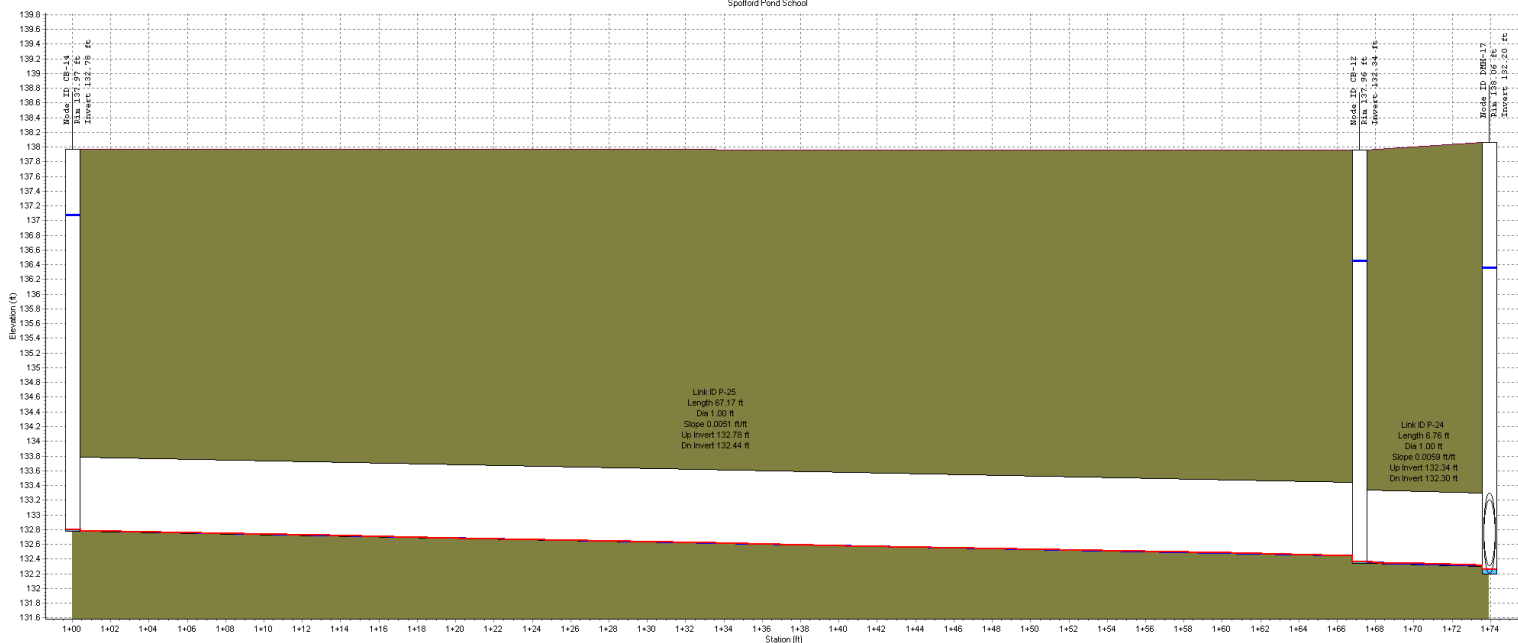

Node ID:	CB-14		CB-12	DMH-17
Rim (ft)	137.57		137.56	138.06
Invert (ft)	132.78		132.34	132.20
Min Pipe Cover (ft)			4.76	
Max HGL (ft)	137.08		136.45	137.02
Link ID:		P-25		P-24
Length (ft)		67.77		6.76
Dia (ft)		1.00		1.00
Slope (ft/ft)		0.0051		0.0059
Up Invert (ft)		132.78		132.34
Dn Invert (ft)		132.44		132.30
Max Q (cfs)		0.91		0.77
Max Vel (ft/s)		1.15		1.68
Max Depth (ft)		1.00		1.00

Attachment F - Long Term Pollution Prevention Plan

Long Term Pollution Prevention Plan Spofford Pond School Boxford, MA

To meet the requirements of Standard 4 of the Massachusetts Stormwater Handbook, this Long Term Pollution Prevention Plan is provided to identify the proper procedures of practices for source control and pollution prevention.

Storage and Handling of Oil and other Hazardous Materials

Any hazardous materials that will be used ancillary to the school will be stored inside, or off site.

Spill Prevention/Response

Spill kits will be kept on site, and spills shall be cleaned up immediately. Spills of any hazardous material over 10 gallons will be reported to the Massachusetts Department of Environmental Protection within 24 hours.

Operation and Maintenance of Stormwater Control Structures

Included in Attachment H of this appendix is the Operation and Maintenance plan for this site, which includes street sweeping of the paved areas and periodic cleaning of stormwater structures. The town will be responsible for the implementation of the plan.

Landscaping

The landscaped areas will be maintained by the town. Use of fertilizers, herbicides, and pesticides shall be allowed for all vegetated areas on site. If kept on site, all chemicals shall be stored under cover. Any storage for fertilizers, herbicides and pesticides shall not be located within 100 feet of any wetland or within proximity to the stormwater management system where spills could enter the storm drain system.

Septic System

There will be no new onsite septic facilities. The sewer facilities currently in use for the existing building on site shall be retained.

Vehicle Washing

Vehicle washing shall not be performed on site. Vehicles can be rinsed with a high volume of water at low pressure. This is considered dust water by the DEP and accounts for what may be rinsed off of the vehicle when it rains. Pre-treatment BMP's downstream of these activities will include deep-sump hooded catch basins.

Non-Hazardous Waste Management/Good Housekeeping Practices

All non-hazardous waste shall be stored in designated trash or recycling containers onsite for periodic collection by the local trash collector. The town shall have maintenance staff who monitor the site for the accumulation of trash. Any trash that is seen onsite shall immediately be collected and placed into designated trash or recycling containers. The town's maintenance staff shall inspect the site once per week at minimum.

Prohibition of Illicit Discharges

Illicit discharges to the onsite stormwater management system shall be strictly prohibited. Illicit discharges are defined as any direct or indirect non-stormwater discharge to the onsite stormwater system. Requirements related to Illicit Discharges are further detailed in the attached Illicit Discharge Compliance Statement.

De-icing & Snow Disposal

The operation will utilize salt and sand to treat the paved surfaces of the site during snow and ice events. Snow will be temporarily stored within peripheral areas of the site and allowed to melt and drain back to onsite stormwater systems. When needed, snow shall be removed from the site and disposed of in accordance with all local, state and federal regulations. Snow storage shall be prohibited within all wetlands and wetland buffer zones. Salt use shall be restricted within areas that discharge stormwater into bioretention areas.

Winter Sand/Salt Use & Storage

Any sand and/or salt to be used for de-icing purposes shall be stored inside or under cover and stabilized to prevent the discharge into nearby wetlands or waterbodies.

Emergency Contact Information

Owner/Operator:

Tri-Town School Union
Stephen Clifford
Director of Facilities
26 Middleton Road
Boxford, MA 01921

Engineer:

James Pearson, P.E.
Weston & Sampson, Inc.
55 Walkers Brook Drive, Suite 100
Reading, MA 01867
978-532-1900

**Attachment G - Construction Period Pollution and Erosion
and Sedimentation Control Plan**

Construction Period Pollution Prevention and Erosion and Sedimentation Control Plan

SECTION 1: Introduction

The project applicant, the Town of Boxford, proposes a redevelopment project at the Spofford Pond School located at 31 Spofford Road in Boxford to improve site access and traffic circulation. Site work will include, but is not limited to grading, drainage, paving and landscaping.

As part of this project, this “Construction Period Pollution Prevention and Erosion and Sedimentation Control Plan” has been created to ensure that onsite erosion is prevented and sediment is controlled to prevent it from leaving the site.

SECTION 2: Construction Period Pollution Prevention Measures

Best Management Practices (BMPs) will be utilized as Construction Period Pollution Prevention Measures to reduce potential pollutants and prevent any off-site discharge. The objectives of the BMPs for construction activity are to minimize the disturbed areas, stabilize any disturbed areas, control the site perimeter and retain sediment. Both erosion and sedimentation controls and non-stormwater best management measures will be used to minimize site disturbance and ensure compliance with the performance standards of the WPA and Stormwater Standards. Measures will be taken to minimize the area disturbed by construction activities to reduce the potential for soil erosion and stormwater pollution problems. All pollution prevention and erosion control measures which are required on the site plans and in the SWPPP shall be followed along with the guidance in this document. In addition, good housekeeping measures will be followed for the day-to-day operation of the construction site under the control of the contractor to minimize the impact of construction. This section describes the control practices that will be in place during construction activities. All recommended control practices will comply with the standards set in the MA DEP Stormwater Policy Handbook.

2.1 Minimize Disturbed Area and Protect Natural Features and Soil

In order to minimize disturbed areas all work will be completed within well-defined work limits. These work limits are shown on the construction plans. The Contractor shall not disturb native vegetation in the undisturbed wooded area without prior approval from the Engineer. The Contractor will be responsible to make sure that all workers know the proper work limits and do not extend their work into the undisturbed areas. The protective measures are described in more detail in the following sections.

2.2 Control Stormwater Flowing onto and through the project

All construction areas adjacent to drainage features will be lined with compost filter tubes and silt fence. The tubes and silt fence will be inspected daily and accumulated silt will be removed as appropriate. In addition, any storage of material will require a second level of protection by surrounding the areas with another row of compost filter tubes. A stabilized construction entrance/exit is proposed so that equipment visiting the site can remove any accumulated dirt and mud from vehicles to prevent tracking the mud onto public roads.

2.3 Stabilize Soils

The Contractor shall limit the area of land which is exposed and free from vegetation during construction. In areas where the period of exposure will be greater than two (2) months, mulching, the use of erosion control mats, or other protective measures shall be provided as specified.

The Contractor shall take account of the conditions of the soil where erosion control seeding will take place to ensure that materials used for re-vegetation are adaptive to the sediment control.

Following the completion of construction, embankment areas will be finished with topsoil and seed. Slopes in excess of 3H:1V will be stabilized with erosion matting to prevent erosion during the interim period in which vegetation is being established. The overland areas of the proposed construction staging areas will also be re-seeded.

2.4 Proper storage and cover of any stockpiles

The location of the Contractor's storage areas for equipment and/or materials shall be upon cleared portions of the job site or areas to be cleared as a part of this project and shall require written approval of the Engineer.

Adequate measures for erosion and sediment control such as the placement of compost filter tubes around the downstream perimeter of stockpiles shall be employed to protect any downstream areas from siltation.

The Engineer may designate a particular area or areas where the Contractor may store materials used in his operations.

2.5 Perimeter Controls and Sediment Barriers

Erosion control lines as described in Section 5 will be utilized to ensure that no sedimentation occurs outside the perimeter of the work area.

2.6 Storm Drain Inlet Protection

Storm drain inlets will be protected from sediment.

2.7 Retain Sediment On-Site

The Contractor will be responsible to monitor all erosion control measures. Whenever necessary the Contractor will clear all sediment from the compost filter tubes and silt fence that have been silted up during construction. Daily monitoring should be conducted using the attached Monitoring Form.

The following good housekeeping practices will be followed on-site during the construction project.

2.8 Material Handling and Waste Management

All materials stored on-site will be stored in a neat, orderly manner in appropriate containers. All materials will be kept in their original containers with the original manufacturer's label. Substances will not be mixed with one another unless recommended by the manufacturer.

All waste materials will be collected and stored in a securely lidded metal container from a licensed management company. The waste and any construction debris from the site will be hauled off-site daily and disposed of properly. The contractor will be responsible for all waste removal. Manufacturer's recommendations for proper use and disposal will be followed for all materials. Sanitary waste will be collected from the portable units a minimum of once a week, by a licensed sanitary waste management contractor.

2.9 Designated Washout Areas

The Contractor shall perform washout into contained areas designated for that purpose to prevent cement-laden water from leaving the site.

2.10 Proper Equipment/Vehicle Fueling and Maintenance Practices

On-site vehicles will be monitored for leaks and receive regular preventative maintenance to reduce the risk of leakage. To ensure that leaks on stored equipment do not contaminate the site, oil-absorbing mats will be placed under all equipment during storage. Regular fueling and service of the equipment may be performed using approved methods and with care taken to minimize chance of spills. Any petroleum products will be stored in tightly sealed containers that are clearly labeled.

2.11 Equipment/Vehicle Washing

The Contractor will be responsible to ensure that no equipment is washed on-site.

SECTION 3: Spill Prevention and Control Plan

The Contractor will be responsible for preventing spills in accordance with the project specifications and applicable federal, state and local regulations. The Contractor will identify a properly trained site employee, involved with the day-to-day site operations to be the spill prevention and cleanup coordinator. The name(s) of the responsible spill personnel will be posted on-site. Each employee will be instructed that all spills are to be reported to the spill prevention and cleanup coordinator.

3.1 Spill Control Equipment

Spill control/containment equipment will be kept in the Work Area. Materials and equipment necessary for spill cleanup will be kept either in the Work Area or in an otherwise accessible on-site location. Equipment and materials will include, but not be limited to, absorbent booms/mats, brooms, dust pans, mops, rags, gloves, goggles, sand, plastic and metal containers specifically for this purpose. It is the responsibility of the Contractor to ensure the inventory will be readily accessible and maintained.

3.2 Notification

All workers will be directed to inform the on-site supervisor of a spill event. The supervisor will assess the incident and initiate proper containment and response procedures immediately upon notification. Workers should avoid direct contact with spilled materials during the containment procedures. Primary notification of a spill should be made to the local Fire Department and Police Departments. Secondary Notification will be to the certified cleanup contractor if deemed necessary by Fire and/or Police personnel. The third level of notification is to the DEP. The specific cleanup contractor to be used will be identified by the Contractor prior to commencement of construction activities.

3.3 Spill Containment and Clean-Up Measures

Spills will be contained with granular sorbent material, sand, sorbent pads, booms or all of the above to prevent spreading. Certified cleanup contractors should complete spill cleanup. The material manufacturer's recommended methods for spill cleanup will be clearly posted and on-site personnel will be

made aware of the procedures and the location of the information and cleanup supplies.

3.4 Hazardous Materials Spill Report

The Contractor will report and record any spill. The spill report will present a description of the release, including the quantity and type of material, date of the spill, circumstances leading to the release, location of spill, response actions and personnel, documentation of notifications and corrective measures implemented to prevent reoccurrence.

This document does not relieve the Contractor of the Federal reporting requirements of 40 CFR Part 110, 40 CFR Part 117, 40 CFR Part 302 and the State requirements specified under the Massachusetts Contingency Plan (M.C.P) relating to spills or other releases of oils or hazardous substances. Where a release containing a hazardous substance or oil in an amount equal to or in excess of a reportable quantity established under either 40 CFR Part 110, 40 CFR Part 117 or 40 CFR Part 302, occurs during a twenty-four (24) hour period, the Contractor is required to comply with the response requirements of the above mentioned regulations. Spills of oil or hazardous material in excess of the reportable quantity will be reported to the National Response Center (NRC).

SECTION 4: Contact Information/Responsible Parties

Owner/Operator:

Tri-Town School Union
Stephen Clifford
Director of Facilities
26 Middleton Road
Boxford, MA 01921
978-887-0771

Engineer:

James Pearson, P.E.
Weston & Sampson, Inc.
55 Walkers Brook Drive, Suite 100
Reading, MA 01867
978-532-1900

Site Inspector:

TBD

Contractor:

TBD

SECTION 5: Erosion and Sedimentation Control

Erosion and Sedimentation Controls are shown on the project plans. A Stormwater Pollution Prevention Plan (SWPPP) will be required for this project in accordance with EPA regulations. The contractor shall refer to the SWPPP for additional requirements.

SECTION 6: Site Development Plans

A full set of site development plans are included with this submittal.

SECTION 7: Operation and Maintenance of Erosion Control

If there is a failure to the controls the Contractor, under the supervision of the Engineer, will be required to stop work until the failure is repaired.

Periodically throughout the work, whenever the Engineer deems it necessary, the sediment that has been deposited against the controls will be removed to ensure that the controls are working properly.

SECTION 8: Inspection Schedule

During construction the erosion and sedimentation controls will be inspected daily. Once the Contractor is selected, an on site inspector will be selected to work closely with the Engineer to insure that all erosion and sedimentation controls are in place and working properly. An Inspection Form is included.

Construction Period Pollution Prevention and Erosion and Sedimentation Control Plan

Spofford Pond School – Boxford, MA

Inspection Form

Inspected By: _____ Date: _____ Time: _____

YES	NO	DOES NOT APPLY	ITEM
			Do any erosion/siltation control measures require repair or clean out to maintain adequate function?
			Is there any evidence that sediment is leaving the site and entering the wetlands?
			Are any temporary soil stockpiles or construction materials located in non-approved areas?
			Are on-site construction traffic routes, parking, and storage of equipment and supplies located in areas not specifically designed for them?
			Is there any evidence that sediment is entering subsurface stormwater chamber systems?

Specific location, current weather conditions, and action to be taken:

Other Comments:

Pending the actions noted above I certify that the site is in compliance with the Construction Period Pollution Prevention and Erosion and Sedimentation Control Plan.

Signature: _____ Date: _____

Attachment H - Operations and Maintenance Plan

1.0 Introduction

The following document has been written to comply with the stormwater guidelines set forth by the Massachusetts Department of Environmental Protection (MassDEP). The intent of these guidelines is to encourage Low Impact Development techniques to improve the quality of the stormwater runoff. These techniques, also known as Best Management Practices (BMPs) collect, store, and treat the runoff before discharging to adjacent environmental resources.

2.0 Purpose

This Operation and Maintenance Plan (O&M Plan) is intended to provide a mechanism for the consistent inspection and maintenance of each BMP installed on the project site. Included in this O&M Plan is a description of each BMP type and an inspection form for each BMP. The Town of Boxford is the owner and operator of the system and is responsible for its upkeep and maintenance. This work will be funded on an annual basis through the owner's operating budget.

In the event the Owner sells the property, it is the Owner's responsibility to transfer this plan as well as the design plans, shop drawings, as-built plans, and past three years of operation and maintenance records to the new property owner.

3.0 BMP Description and Locations

3.1 Street Sweeping

Street sweeping consists of using a sweeper machine to clean impervious areas of accumulated sediment, debris, and trash at paved areas.

3.2 Deep Sump Catch Basins

Deep sump catch basins utilizing catch basin hoods will be located throughout the site and used as pre-treatment before entering the infiltration systems or other Town stormwater infrastructure. The deep sump catch basins are designed to remove trash, debris, hydrocarbons, and coarse sediment from the stormwater runoff.

3.3 Stormtech Isolator Row

The subsurface chamber systems will contain a Stormtech Isolator Row for TSS removal. The Isolator Row consists of Stormtech stormwater chambers wrapped in geotextile fabric.

3.4 Stormtech Subsurface Chamber System

The subsurface chamber systems use infiltration or detention to mitigate peak runoff rates from the site. The structure also significantly mitigates TSS.

3.5 Outlet Control Structure

The outlet control structures are used to control discharges from captured stormwater. They release the water in a controlled manner to control peak discharges.

3.6 Drain Manholes

Drain Manholes will be located throughout the site and used to convey and redirect stormwater collected from deep sump catch basins. They allow for access, connection points, and change-in-direction points in the underground drainage system.

3.7 Sediment Forebay

The sediment forebay will collect runoff from paved surfaces and will pre-treat flows prior to discharge to the Underground Stormtech chambers. The sediment forebay slows velocities of incoming stormwater, is easily accessible for sediment removal, and provides greater detention time compared to proprietary separators.

3.8 Pre-existing Stormwater Vaults

There are a few existing stormwater vaults within the site that were installed in the mid-1990s on this site. These appear to have some sediment capture capability.

4.0 Inspection, Maintenance Checklist and Schedule

4.1 Street Sweeping

Street sweeping shall be performed on all impervious surfaces on a quarterly average, with sweeping performed primarily in the spring and fall. Street sweeping shall be performed using a high efficiency vacuum street sweeping machine or a regenerative air sweeper. A mechanical rotary broom sweeper may be used if sweeping is performed on a monthly basis.

In the event of contamination by a spill or other means, all street sweeping cleanings must be evaluated in accordance with the Hazardous Waste Regulations, 310 CMR 30.000 and handled as hazardous waste.

In the absence of evidence of contamination, street sweeping cleanings may be taken to a landfill or other facility permitted by MassDEP to accept Solid Waste without any prior approval by MassDEP. Please note that current MassDEP regulations prevent landfills from accepting materials that contain free-draining liquids.

4.2 Deep Sump Catch Basins and Outlet Control Structures

Inspect and/or clean catch basin and outlet control structures at least four times per year and at the end of foliage and snow removal seasons. Sediments must be removed whenever the depth of deposits is greater than or equal to one half the depth from the bottom of the invert of the lowest pipe in the basin. The structures should be cleaned a minimum of four times per year regardless of the amount of sediment in the basin. If catch basins are found to be filled to capacity with sediment during a cleaning, the frequency of cleaning shall be increased. Catch basins and outlet control structures shall be cleaned with clamshell buckets or by hand tools where necessary. Catch basin hoods shall be inspected annually. Open and close the access hatch and flush or rod the anti-siphon device to ensure proper operation.

In the event of contamination by a spill or other means, all cleanings must be evaluated in accordance with the Hazardous Waste Regulations, 310 CMR 30.000 and handled as hazardous waste.

In the absence of evidence of contamination, catch basin cleanings may be taken to a landfill or other facility permitted by MassDEP to accept Solid Waste without any prior approval by MassDEP. Please note that current MassDEP regulations prevent landfills from accepting materials that contain free-draining liquids.

4.3 Stormtech Isolator Row

Stormtech Isolator Rows shall be inspected every six months for the first year, then timed thereafter based upon the depth of sediment build up witnessed in the previous inspections. Inspection ports shall be located strategically throughout the isolator row system. When sediment is observed, the depth shall be recorded with a stadia rod, and when that average depth across the chambers reaches 3-inches, the system shall be cleaned out.

Cleaning is performed through the Jet-vac process whereby the chambers are washed with a high-pressure water system and the captured pollutants are then vacuumed out.

Refer to the attached Stormtech Isolator Row Operations and Maintenance document for additional information.

4.4 Stormtech Subsurface Chamber System

Stormtech subsurface chambers shall be inspected every three months for the first year, then timed thereafter based upon the depth of sediment build up witnessed in the previous inspections. Inspection ports shall be located strategically throughout the isolator row system. When sediment is observed, the depth shall be recorded with a stadia rod, and when that average depth across the isolator row reached 3-inches, the system shall be cleaned out.

Cleaning is performed through the Jet-vac process whereby the isolator chambers are washed with a high-pressure water system and the captured pollutants are then vacuumed out.

Refer to the attached Stormtech Operations and Maintenance document for additional information.

4.5 Drain Manholes

Inspect and/or clean drain manholes at least four times per year while inspecting the catch basins. Remove all accumulated sediments and debris, and dispose of in accordance with local, state, and federal regulations. Drain Manholes shall be cleaned with clamshell buckets or by hand tools where necessary.

In the event of contamination by a spill or other means, all cleanings must be evaluated in accordance with the Hazardous Waste Regulations, 310 CMR 30.000 and handled as hazardous waste.

In the absence of evidence of contamination, manhole cleanings may be taken to a landfill or other facility permitted by MassDEP to accept Solid Waste without any prior approval by MassDEP. Please note that current MassDEP regulations prevent landfills from accepting materials that contain free-draining liquids.

4.6 Inspections and Record Keeping

- An inspection form should be filled out each and every time maintenance work is performed.
- A binder should be kept at the facility that contains all of the completed inspection forms and any other related materials.
- A review of all Operation & Maintenance actions should take place annually to ensure that these Stormwater BMPs are being taken care of in the manner illustrated in this Operation & Maintenance Plan.
- All operation and maintenance log forms for the last three years, at a minimum, shall be kept on site at the facility.
- The inspection and maintenance schedule may be refined in the future based on the findings and results of this operation and maintenance program or policy.

4.8 Sediment Forebay

Sediments and associated pollutants are removed only when sediment forebays are cleaned out. Frequently removing accumulated sediments will make it less likely that sediments will be resuspended. At a minimum, inspect sediment forebays monthly and clean them out at least four times per year. Stabilize the floor and sidewalls of the sediment forebay before making it operational in order to avoid discharging excess amounts of suspended sediments.

When mowing grasses, keep the grass height no greater than 6 inches. Set mower blades no lower than 3 to 4 inches. Check for signs of rilling and gulying and repair as needed. After removing the sediment, replace any vegetation damaged during the clean-out by either reseeding or resodding. When reseeding, incorporate practices such as hydroseeding with a tackifier, blanket, or similar practice to ensure that no scour occurs in the forebay, while the seeds germinate and develop roots. Maintenance shall be conducted in accordance with the following schedule:

Activity	Time of Year	Frequency
Inspect & remove trash	Year round	Monthly
Remove dead vegetation	Fall or Spring	Annually
Replace dead vegetation	Spring	Annually
Prune	Spring or Fall	Annually
Replace entire media & all vegetation	Late Spring/early Summer	As needed*

4.9 Pre-existing Stormwater Vaults

There are a few existing stormwater vaults on the site that were installed in the mid-1990's. These shall be maintained using the same procedures described above for deep sump hooded catch basins.

5 **Stormwater Management System Owner/Responsible Party**

The stormwater management system shall be owned and maintained by the following party or its future designee/assigns:

Tri-Town School Union
Stephen Clifford – Director of Facilities
26 Middleton Road
Boxford, MA 01921

This operation and Maintenance Plan will be recorded with the registry of deeds so that current and future owners are aware of the requirement for proper operation and maintenance of the onsite stormwater system.

6 General Good Housekeeping Practices

All non-hazardous waste shall be stored in designated trash or recycling containers onsite for periodic collection by the local trash collector. The owner shall have maintenance staff who monitor the site for the accumulation of trash. Any trash that is seen onsite shall immediately be collected and placed into designated trash or recycling containers. The owner's maintenance staff shall make an inspection of the site once per week at minimum.

7 Estimated Operations and Maintenance Budget

The estimated budget for annual operations and maintenance of this stormwater system is \$2,000 per year.

Spofford Pond School
Permanent BMP Inspection Checklist

Street Sweeping

Frequency: Quarterly average, primarily in the spring and fall if using a high efficiency vacuum sweeper or regenerative air sweeper. Monthly, if using a mechanical rotary broom sweeper.

Location: Parking Areas, Driveways and Roadway

Inspected By: _____ Date: _____

Observations: _____

Actions Taken: _____

Instructions: Sweep all impervious areas, including parking lots, driveways, and roadways using high efficiency vacuum street sweeping machine, regenerative air sweeper, or mechanical rotary broom sweeper. All trash, debris, and sediments should be disposed of in accordance with local, state, and federal regulations.

Deep Sump Catch Basins, Outlet Control Structures & Vaults

Frequency: Inspect and clean deep sump catch basins, outlet control structures and stormwater vaults in March, June, September and December.

Structure Number: _____

Inspected By: _____ Date: _____

Observations: _____

Actions Taken: _____

Instructions: Clean units four times per year or whenever the depth of the deposits is greater than or equal to one half the depth from the bottom of the invert to the lowest pipe in the structure. Open and close hood and check anti-siphon vent for clogging.

Subsurface Chamber System & Isolator Row

Frequency: Inspect and clean chamber system and isolator row every six months for the first year and annually thereafter.

Structure Number: _____

Inspected By: _____ Date: _____

Observations: _____

Actions Taken: _____

Instructions: Clean the system whenever the depth of the deposits averages three inches in depth across the bottom of the chambers. Inspect chambers via manholes or inspection ports. Use reverse water jet to pull sediment back into manhole. Remove sediment, trash and debris as noted above.

Drain Manholes

Frequency: Inspect and clean drain manholes in March, June, September and December.

Structure Number: _____

Inspected By: _____ Date: _____

Observations: _____

Actions Taken: _____

Instructions: Clean units four times per year at a minimum, or whenever catch basins are inspected. Remove sediment and debris. All debris, and sediments should be disposed of in accordance with local, state, and federal regulations. Drain Manholes shall be cleaned with clamshell buckets or by hand tools where necessary.

Sediment Forebay

Frequency: Inspect monthly. Clean four times per year.

Structure Number: _____

Inspected By: _____ Date: _____

Observations: _____

Actions Taken: _____

Instructions: Clean sediment forebays four times per year and when sediment depth is between 3 to 6 feet. When moving grasses, keep the grass height no greater than 6 inches. Check for signs of riling and gullyng and repair as needed. After removing sediment, replace any vegetation during the clean-out by either reseeding or resodding. When reseeding, incorporate practices such as hydroseeding with a tackifier, blanket, or similar practice to ensure that no scour occurs in the forebay, while the seeds germinate and develop Roots.

Isolator[®] Row O&M Manual



THE ISOLATOR[®] ROW

INTRODUCTION

An important component of any Stormwater Pollution Prevention Plan is inspection and maintenance. The StormTech Isolator Row is a technique to inexpensively enhance Total Suspended Solids (TSS) removal and provide easy access for inspection and maintenance.

THE ISOLATOR ROW

The Isolator Row is a row of StormTech chambers, either SC-160LP, SC-310, SC-310-3, SC-740, DC-780, MC-3500 or MC-4500 models, that is surrounded with filter fabric and connected to a closely located manhole for easy access. The fabric-wrapped chambers provide for settling and filtration of sediment as storm water rises in the Isolator Row and ultimately passes through the filter fabric. The open bottom chambers and perforated sidewalls (SC-310, SC-310-3 and SC-740 models) allow storm water to flow both vertically and horizontally out of the chambers. Sediments are captured in the Isolator Row protecting the storage areas of the adjacent stone and chambers from sediment accumulation.

Two different fabrics are used for the Isolator Row. A woven geotextile fabric is placed between the stone and the Isolator Row chambers. The tough geotextile provides a media for storm water filtration and provides a durable surface for maintenance operations. It is also designed to prevent scour of the underlying stone and remain intact during high pressure jetting. A non-woven fabric is placed over the chambers to provide a filter media for flows passing through the perforations in the sidewall of the chamber. The non-woven fabric is not required over the SC-160LP, DC-780, MC-3500 or MC-4500 models as these chambers do not have perforated side walls.

The Isolator Row is typically designed to capture the “first flush” and offers the versatility to be sized on a volume basis or flow rate basis. An upstream manhole not only provides access to the Isolator Row but typically includes a high flow weir such that storm water flowrates or volumes that exceed the capacity of the Isolator Row overtop the overflow weir and discharge through a manifold to the other chambers.

The Isolator Row may also be part of a treatment train. By treating storm water prior to entry into the chamber system, the service life can be extended and pollutants such as hydrocarbons can be captured. Pre-treatment best management practices can be as simple as deep sump catch basins, oil-water separators or can be innovative storm water treatment devices. The design of the treatment train and selection of pretreatment devices by the design engineer is often driven by regulatory requirements. Whether pretreatment is used or not, the Isolator Row is recommended by StormTech as an effective means to minimize maintenance requirements and maintenance costs.

Note: See the StormTech Design Manual for detailed information on designing inlets for a StormTech system, including the Isolator Row.



Looking down the Isolator Row from the manhole opening, woven geotextile is shown between the chamber and stone base.



StormTech Isolator Row with Overflow Spillway (not to scale)

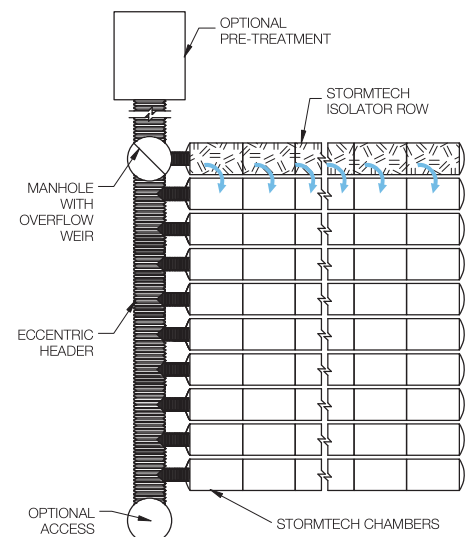



ISOLATOR ROW INSPECTION/MAINTENANCE

INSPECTION

The frequency of inspection and maintenance varies by location. A routine inspection schedule needs to be established for each individual location based upon site specific variables. The type of land use (i.e. industrial, commercial, residential), anticipated pollutant load, percent imperviousness, climate, etc. all play a critical role in determining the actual frequency of inspection and maintenance practices.

At a minimum, StormTech recommends annual inspections. Initially, the Isolator Row should be inspected every 6 months for the first year of operation. For subsequent years, the inspection should be adjusted based upon previous observation of sediment deposition.

The Isolator Row incorporates a combination of standard manhole(s) and strategically located inspection ports (as needed). The inspection ports allow for easy access to the system from the surface, eliminating the need to perform a confined space entry for inspection purposes.

If upon visual inspection it is found that sediment has accumulated, a stadia rod should be inserted to determine the depth of sediment. When the average depth of sediment exceeds 3 inches throughout the length of the Isolator Row, clean-out should be performed.

MAINTENANCE

The Isolator Row was designed to reduce the cost of periodic maintenance. By “isolating” sediments to just one row, costs are dramatically reduced by eliminating the need to clean out each row of the entire storage bed. If inspection indicates the potential need for maintenance, access is provided via a manhole(s) located on the end(s) of the row for cleanout. If entry into the manhole is required, please follow local and OSHA rules for a confined space entries.

Maintenance is accomplished with the JetVac process. The JetVac process utilizes a high pressure water nozzle to propel itself down the Isolator Row while scouring and suspending sediments. As the nozzle is retrieved, the captured pollutants are flushed back into the manhole for vacuuming. Most sewer and pipe maintenance companies have vacuum/JetVac combination vehicles. Selection of an appropriate JetVac nozzle will improve maintenance efficiency. Fixed nozzles designed for culverts or large diameter pipe cleaning are preferable. Rear facing jets with an effective spread of at least 45” are best. Most JetVac reels have 400 feet of hose allowing maintenance of an Isolator Row up to 50 chambers long. **The JetVac process shall only be performed on StormTech Isolator Rows that have AASHTO class 1 woven geotextile (as specified by StormTech) over their angular base stone.**

StormTech Isolator Row (not to scale)

Note: Non-woven fabric is only required over the inlet pipe connection into the end cap for SC-160LP, DC-780, MC-3500 and MC-4500 chamber models and is not required over the entire Isolator Row.

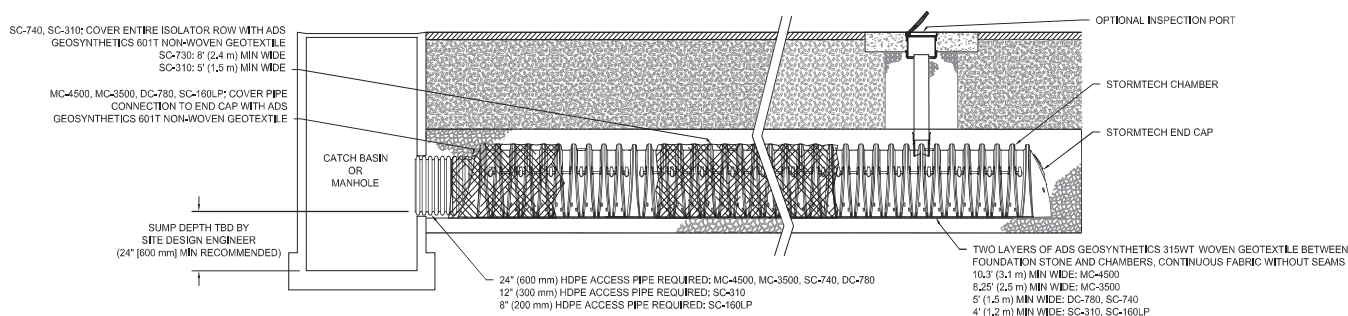

ISOLATOR ROW STEP BY STEP MAINTENANCE PROCEDURES

STEP 1

Inspect Isolator Row for sediment.

- A) Inspection ports (if present)
 - i. Remove lid from floor box frame
 - ii. Remove cap from inspection riser
 - iii. Using a flashlight and stadia rod, measure depth of sediment and record results on maintenance log.
 - iv. If sediment is at or above 3 inch depth, proceed to Step 2. If not, proceed to Step 3.
- B) All Isolator Rows
 - i. Remove cover from manhole at upstream end of Isolator Row
 - ii. Using a flashlight, inspect down Isolator Row through outlet pipe
 - 1. Mirrors on poles or cameras may be used to avoid a confined space entry
 - 2. Follow OSHA regulations for confined space entry if entering manhole
 - iii. If sediment is at or above the lower row of sidewall holes (approximately 3 inches), proceed to Step 2. If not, proceed to Step 3.

STEP 2

Clean out Isolator Row using the JetVac process.

- A) A fixed floor cleaning nozzle with rear facing nozzle spread of 45 inches or more is preferable
- B) Apply multiple passes of JetVac until backflush water is clean
- C) Vacuum manhole sump as required

STEP 3

Replace all caps, lids and covers, record observations and actions.

STEP 4

Inspect & clean catch basins and manholes upstream of the StormTech system.

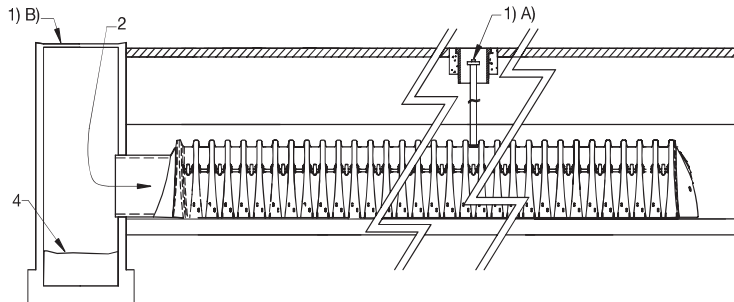

SAMPLE MAINTENANCE LOG

Date	Stadia Rod Readings		Sediment Depth (1)-(2)	Observations/Actions	Inspector
	Fixed point to chamber bottom (1)	Fixed point to top of sediment (2)			
3/15/11	6.3 ft	none		New installation. Fixed point is CI frame at grade	DJM
9/24/11		6.2	0.1 ft	Some grit felt	SM
6/20/13		5.8	0.5 ft	Mucky feel, debris visible in manhole and in Isolator Row, maintenance due	NV
7/7/13	6.3 ft		0	System jetted and vacuumed	DJM

Attachment I – Illicit Discharge Compliance Statement

Illicit Discharge Compliance Statement

Section I – Purpose/Intent

The purpose of this document is to provide for the health, safety, and general welfare of the citizens of Massachusetts through the regulation of non-stormwater discharges into existing outstanding resource areas near the site to the maximum extent practicable, as required by federal and state law. This document establishes methods for controlling the introduction of pollutants into existing outstanding resource areas to comply with requirements of the National Pollutant Discharge Elimination System (NPDES) permit process.

Section II - Definitions

For the purposes of this statement, the following shall mean:

Best Management Practices (BMPs): Schedules of activities, prohibitions of practices, general good housekeeping practices, pollution prevention and educational practices, maintenance procedures, and other management practices to prevent or reduce the discharge of pollutants directly or indirectly to stormwater, receiving waters, or stormwater conveyance systems. BMPs also include treatment practices, operating procedures, and practices to control site runoff, spillage or leaks, sludge or water disposal, or drainage from raw materials storage.

Clean Water Act: The federal Water Pollution Control Act (33 U.S.C § 1251 et seq.), and any subsequent amendments thereto.

Construction Activity: Activities subject to the Massachusetts Erosion and Sedimentation Control Act or NPDES Construction Permits. Such activities include but are not limited to clearing and grubbing, grading, excavating, and demolition.

Hazardous Materials: Any material, including any substance, waste, or combination thereof, which because of its quantity, concentration, or physical, chemical, or infectious characteristics may cause, or significantly contribute to, a substantial present or potential hazard to human health, safety, property, or the environment when improperly treated, stored, transported, disposed of, or otherwise managed.

Illegal Connection: An illegal connection is defined as either of the following:

- a. Any pipe, open channel, drain or conveyance, whether on the surface or subsurface, which allows an illicit discharge to enter the outstanding resource area including but not limited to any conveyances which allow any non-stormwater discharge including sewage, process wastewater, and wash water, regardless of whether said drain or connection has been previously allowed, permitted, or approved by an authorized enforcement agency; or

- b. Any pipe, open channel, drain or conveyance connected to the Town of Boxford storm water treatment system which has not been documented in plans, maps, or equivalent records and approved by an authorized enforcement agency.

Illicit Discharge: Any direct or indirect non-stormwater discharge to the Town of Boxford stormwater treatment system, except as exempted in Section III of this ordinance.

Industrial Activity: Activities subject to NPDES Industrial Permits as defined in 40CFR, Section 122.26 (b) (14).

National Pollutant Discharge Elimination System (NPDES) Stormwater Discharge Permit: A permit issued by MassDEP under authority delegated pursuant to 33 USC § 1342 (b) that authorizes the discharge of pollutants to waters of the United States, whether the permit is applicable on an individual, group, or general area-wide basis.

Town of Boxford Stormwater Treatment System: Any facility, owned or maintained by the Town of Boxford, designed or used for collecting and/or conveying stormwater, including but not limited to roads with drainage systems, Town of Boxford streets, curbs, gutters, inlets, catch basins, piped storm drains, pumping facilities, infiltration, retention and detention basins, natural and man-made or altered drainage channels, reservoirs, and other drainage structures.

Non-Stormwater Discharge: Any discharge to the storm drain system that is not composed entirely of stormwater.

Person: Any individual, association, organization, partnership, firm, joint venture, public or private corporation, trust, estate, commission, board, public or private institution, utility, cooperative, city, county or other political subdivision of the State, interstate body, or any other legal entity.

Pollutant: Anything which causes or contributes to pollution. Pollutants may include, but are not limited to: paints, varnishes, and solvents; petroleum hydrocarbons; automotive fluids; cooking grease; detergents (biodegradable or otherwise); degreasers; cleaning chemicals; non-hazardous liquid and solid wastes; refuse, rubbish, garbage, litter, or other discarded or abandoned objects and accumulations, so that same may cause or contribute to pollution; floatables; pesticides, herbicides, and fertilizers; liquid and solid wastes; sewage, fecal coliform and pathogens; dissolved and particulate metals; animal wastes; wastes and residues that result from constructing a building or structure; concrete and cement; and noxious or offensive matter of any kind.

Pollution: Contamination or other alteration of any water's physical, chemical, or biological properties by addition of any constituent including but not limited to a change in temperature, taste, color, turbidity, or odor of such waters, or the discharge of any liquid, gaseous, solid, radioactive, or other substance into any such waters as will or is likely to create a nuisance or render such waters harmful, detrimental, or injurious to the

public health, safety, welfare, or environment, or to domestic, commercial, industrial, agricultural, recreational, or other legitimate beneficial uses, or to livestock, wild animals, birds, fish or other aquatic life.

Premises: Any building, lot, parcel of land, or portion of land whether improved or unimproved including adjacent sidewalks and parking strips.

Stormwater: Any surface flow, runoff, and drainage consisting entirely of water from any form of natural precipitation and resulting from such precipitation.

Wastewater: Any water or other liquid discharged from a facility, that has been used, as for washing, flushing, or in a manufacturing process, and so contains waste products.

Section III - Prohibitions

Prohibition of Illicit Discharges:

No person shall throw, drain, or otherwise discharge, cause or allow others under its control to throw, drain, or otherwise discharge into the Town of Boxford stormwater treatment system or watercourses any materials, including but not limited to, any pollutants or waters containing any pollutants, other than stormwater. To the best of the knowledge and belief of the site operator, no illicit discharges currently exist at the site. The commencement, conduct or continuance of any illicit discharge to the storm drain system is prohibited except as described as follows:

1. Water line flushing performed by a government agency, other potable water sources, landscape irrigation or lawn watering, diverted stream flows, rising ground water, ground water infiltration to storm drains, uncontaminated pumped ground water, foundation or footing drains (not including active groundwater dewatering systems), crawl space pumps, air conditioning condensation, springs, natural riparian habitat or wetland flows, and any other water source not containing pollutants;
2. Discharges or flows from fire fighting, and other discharges specified in writing by the Town of Boxford as being necessary to protect public health and safety;
3. Dye testing is an allowable discharge, but requires notification to the Town of Boxford prior to the time of the test;
4. Any non-stormwater discharge permitted under an NPDES permit, waiver, or waste discharge order issued to the discharger and administered under the authority of the Federal Environmental Protection Agency, provided that the discharger is in full compliance with all requirements of the permit, waiver, or order and other applicable laws and regulations, and provided that written approval has been granted for a discharge to the Town of Boxford stormwater treatment system.

Section IV - Industrial or Construction Activity Discharges

Any person subject to an industrial or construction activity NPDES stormwater discharge permit shall comply with all provisions of such permit. Proof of compliance with said permit may be required in a form acceptable to the Town of Boxford prior to allowing discharges to the Town of Boxford stormwater treatment system.

Section V - Notification of Spills and Accidental Discharges

Notwithstanding other requirements of law, as soon as any person responsible for a facility, activity or operation, or responsible for emergency response for a facility, activity or operation has information of any known or suspected release of pollutants or non-stormwater discharges from that facility, activity, or operation which are resulting or may result in illicit discharges or pollutants discharging into stormwater, the Town of Boxford stormwater treatment system, State Waters, or Waters of the U.S., said person shall take all necessary steps to ensure the discovery, containment, and cleanup of such release so as to minimize the effects of the discharge. In the event of such a release of hazardous materials, said person shall immediately notify emergency response agencies of the occurrence via emergency dispatch services. In the event of a release of non-hazardous materials, said person shall notify the Town of Boxford in person or by phone no later than the next business day, including the nature, quantity and time of occurrence of the discharge. Notifications in person or by phone shall be confirmed by written notice, via certified mail return receipt requested addressed to the Town of Boxford within three (3) business days of the initial notice. If the discharge of prohibited materials emanates from a commercial or industrial establishment, the owner or operator of such establishment shall also retain an on-site written record of the discharge and the actions taken to prevent its recurrence. Such records shall be retained for at least three years.

IN WITNESS WHEREOF the parties hereto have executed copies of this Agreement on the _____ day of _____, _____.
