

# PLAN TO ACCOMPANY A NOTICE OF INTENT 35 GLENDALE ROAD BOXFORD, MA

SCALE: 1" = 20' DATE: MARCH 14, 2024

SHOWING PROPOSED ADDITION



### LEGEND

- BVW BORDERING VEGETATED WETLAND
- ELEV. ELEVATION
- EP EDGE OF PAVEMENT
- F.F. FIRST FLOOR
- G.F. GARAGE FLOOR
- MAX MAXIMUM
- MIN MINIMUM
- NC NO CHANGE
- N/F NOW OR FORMERLY
- T.O.F. TOP OF FOUNDATION
- UP UTILITY POLE
- WF WETLAND FLAG

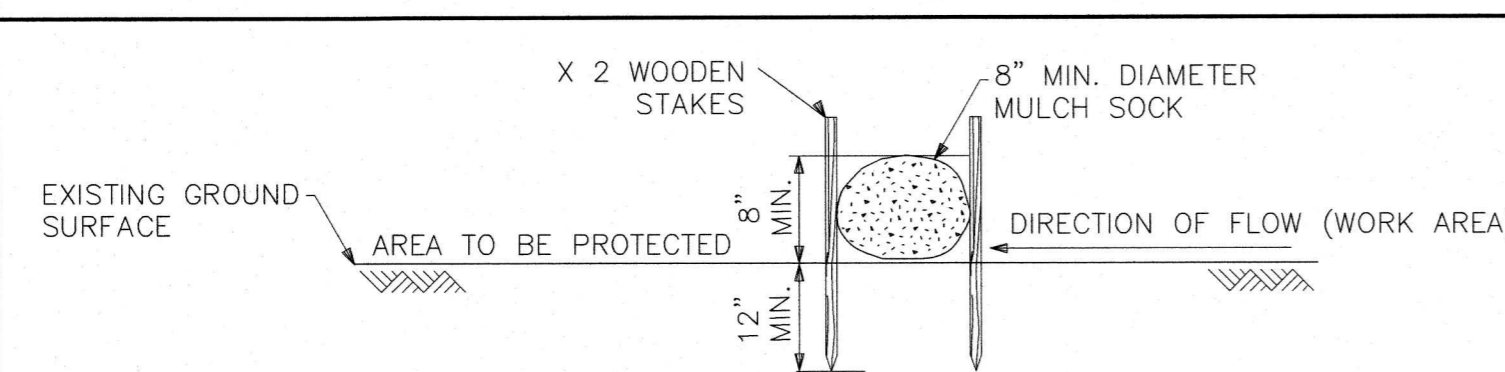
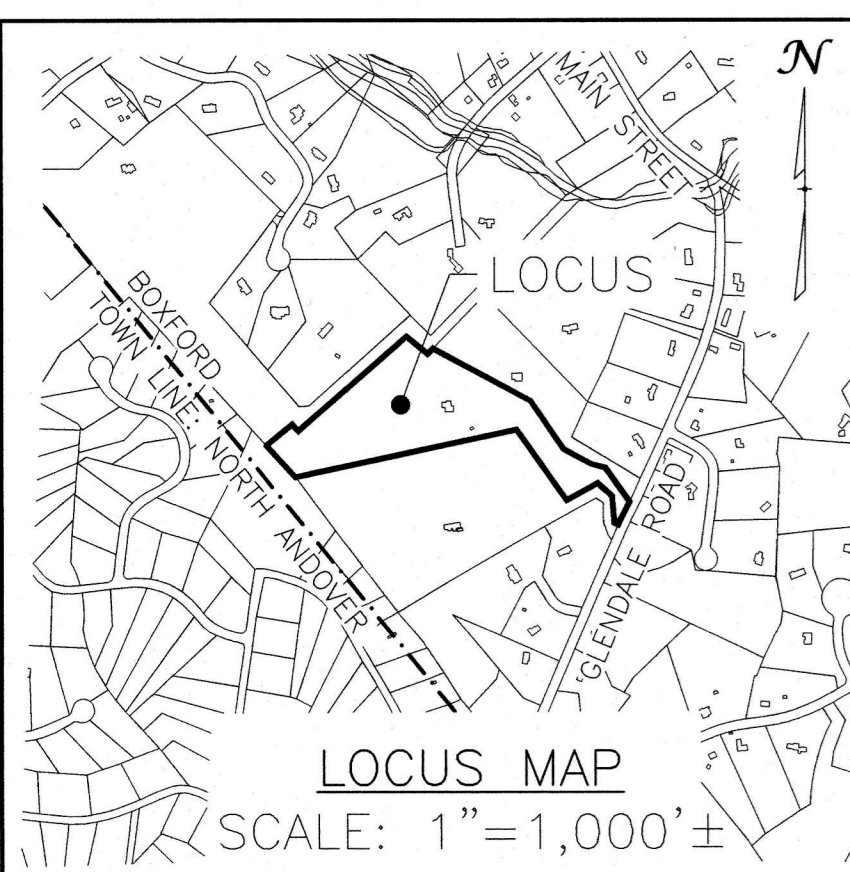

### NOTES:

- SOCK SIZE DEPICTED IS FOR GENERAL USE. GREATER SLOPES MAY REQUIRE LARGER SOCK.
- COMPOST MATERIAL MAY BE DISPERSED ON SITE AT THE DISCRETION OF THE APPROVING AUTHORITY.
- PRIOR TO SETTING THE SOCK, REMOVE LOOSE FOREST LITTER, BRANCHES AND OTHER MATERIAL THAT MAY PREVENT THE SOCK FROM DIRECT CONTACT WITH SOIL.

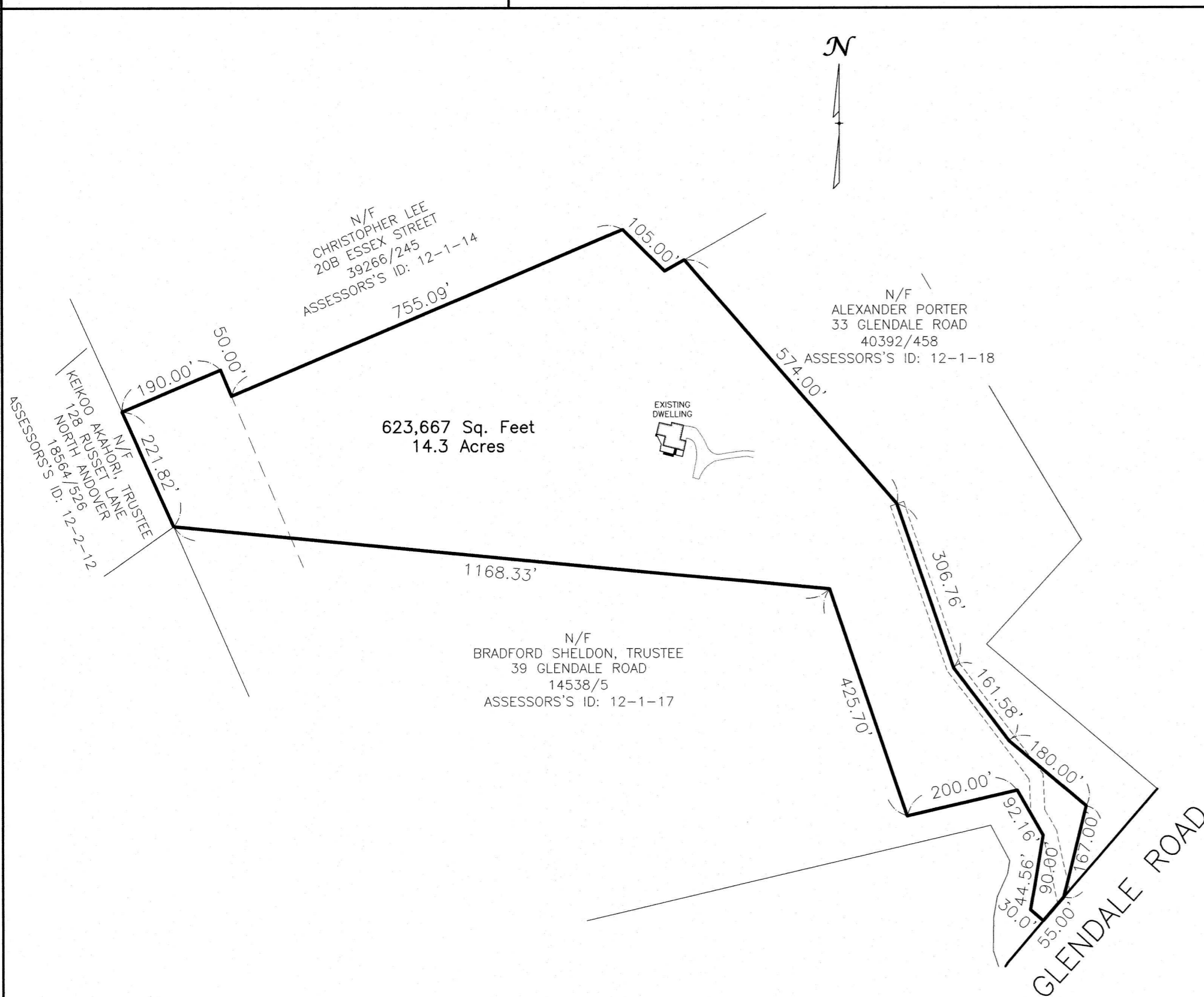

### PROPOSED BUFFER ZONE ENHANCEMENT PLANTINGS:

- ⊗ 2-4' Highbush Blueberry (Vaccinium corymbosum) - FOUR (4)
- ⊙ 2-4' Sweet Pepperbush (Clethra alnifolia) - FOUR (4)

### ASSESSORS REFERENCE:

PROPERTY ID: 12-01-16

ZONE: RESIDENTIAL A (RA)

	REQUIRED/ALLOWED	PROVIDED
LOT AREA	2 ACRES (MIN.)	14.3± ACRES
MINIMUM LOT FRONTAGE	250 ft./*50 ft.	55 ft.
LOT WIDTH	200 DIA. CIRCLE	200' DIA. CIRCLE
MINIMUM FRONT SETBACK	50 ft.	190 ft.
MINIMUM SIDE SETBACK	25 ft.	75.4 ft.
MINIMUM REAR SETBACK	20 ft.	340' ft.
BUILDING HEIGHT	35' / 3 STORIES	<35' / 2 STORIES
IRREGULARLY SHAPED LOT	IF < 20% OF THE AREA OF A SQUARE LOT OF THE SAME PERIMETER	42.2%

\*MINIMUM FRONTAGE OF 50' PROVIDED THE LOT EXCEEDS 4 ACRES AND A WIDTH OF NOT LESS THAN 50' AT ANY POINT BETWEEN THE STREET AND THE SITE OF THE DWELLING.

### PLAN NOTES:

- THE PURPOSE OF THIS PLAN IS TO PROPOSE AN ADDITION TO THE EXISTING HOUSE, RELOCATE THE EXISTING SEPTIC TANK AND IS TO BE FILED AS PART OF AN APPLICATION FOR A NOTICE OF INTENT WITH THE BOXFORD CONSERVATION COMMISSION.
- WETLAND RESOURCES DELINEATED BY WILLIAMS & SPARAGES, LLC ON 12/5/2022.
- ELEVATIONS BASED ON AN ASSUMED DATUM.
- TOPOGRAPHIC FEATURES SHOWN ARE THE RESULT OF AN ACTUAL ON-THE-GROUND FIELD SURVEY BY WILLIAMS & SPARAGES, LLC.
- ABUTTER INFORMATION TAKEN FROM THE TOWN OF BOXFORD ASSESSORS GIS WEBSITE.

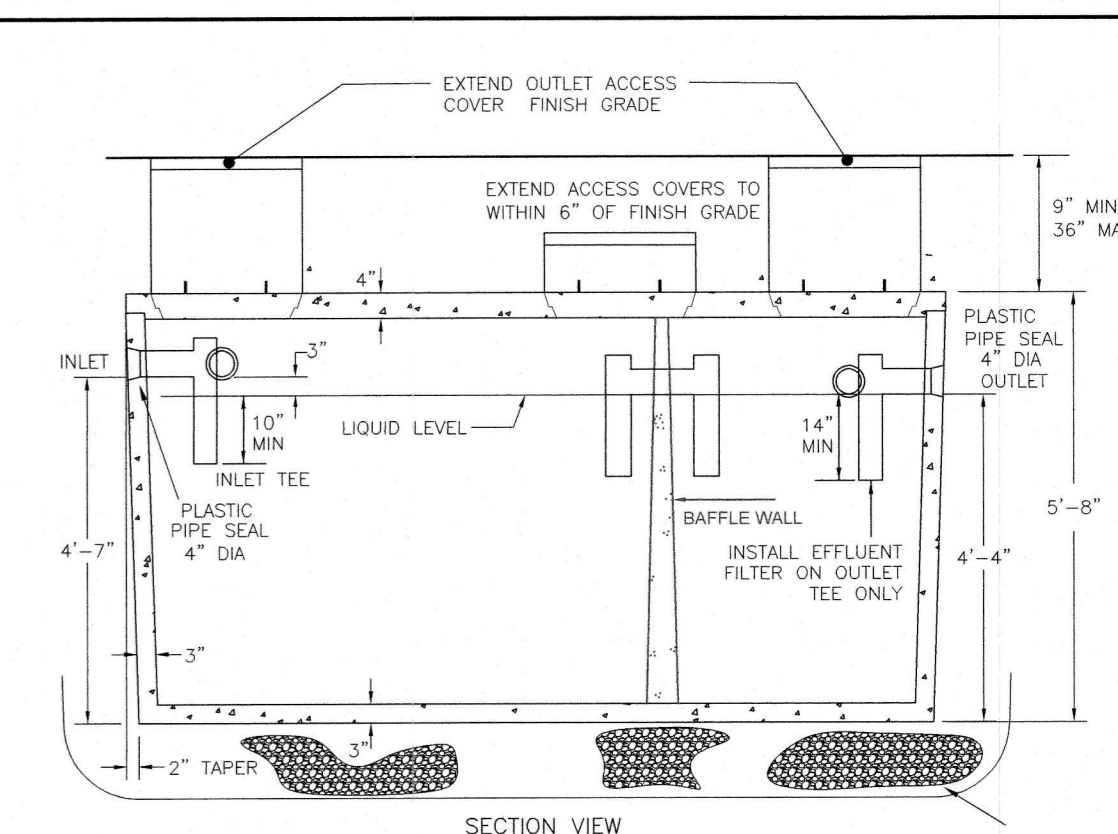
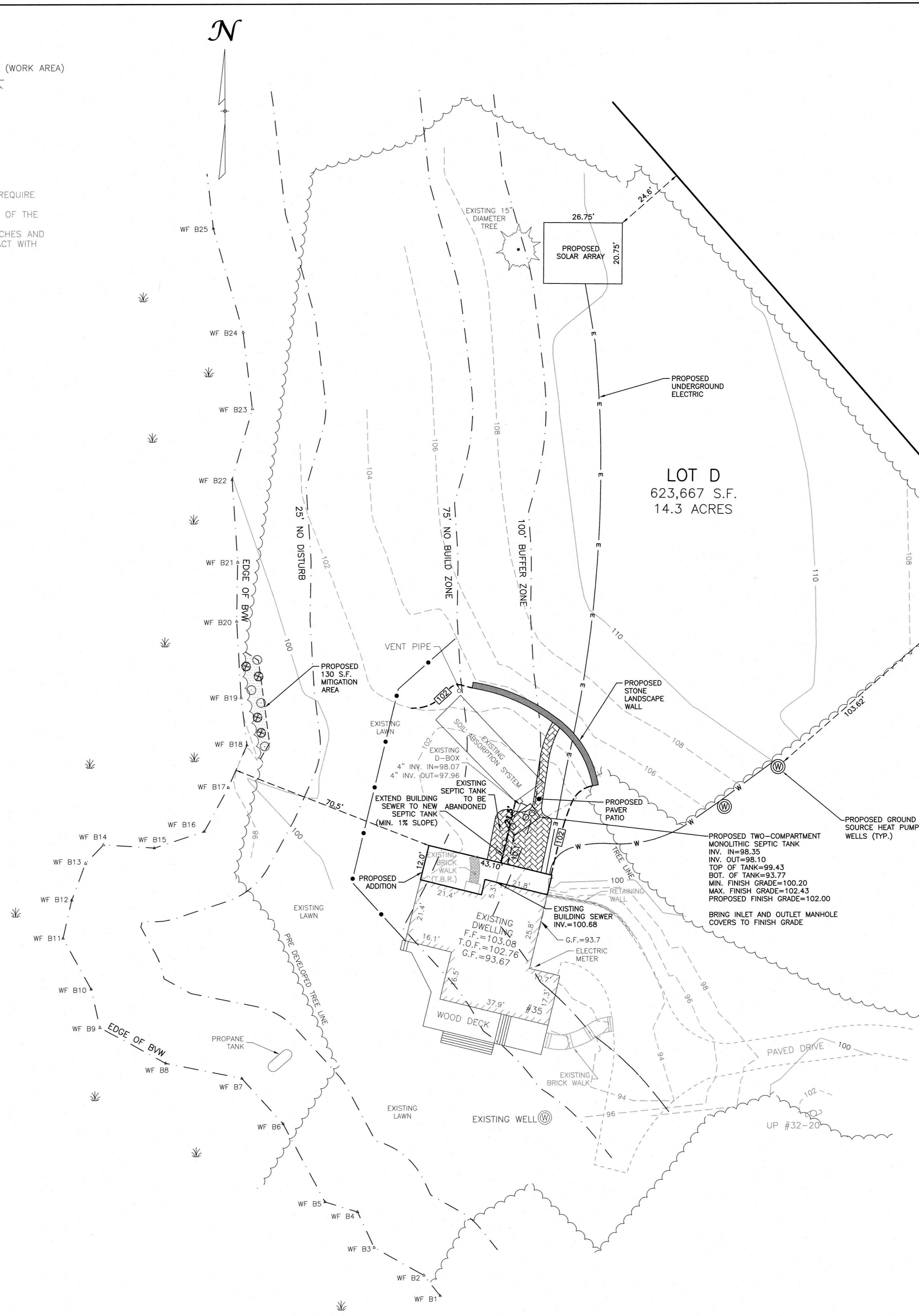

USE SHEA CONCRETE PRODUCTS MODEL NO. TKM1500-3 OR APPROVED EQUAL 6" DEPTH OF 3/4" TO 1-1/2" STONE

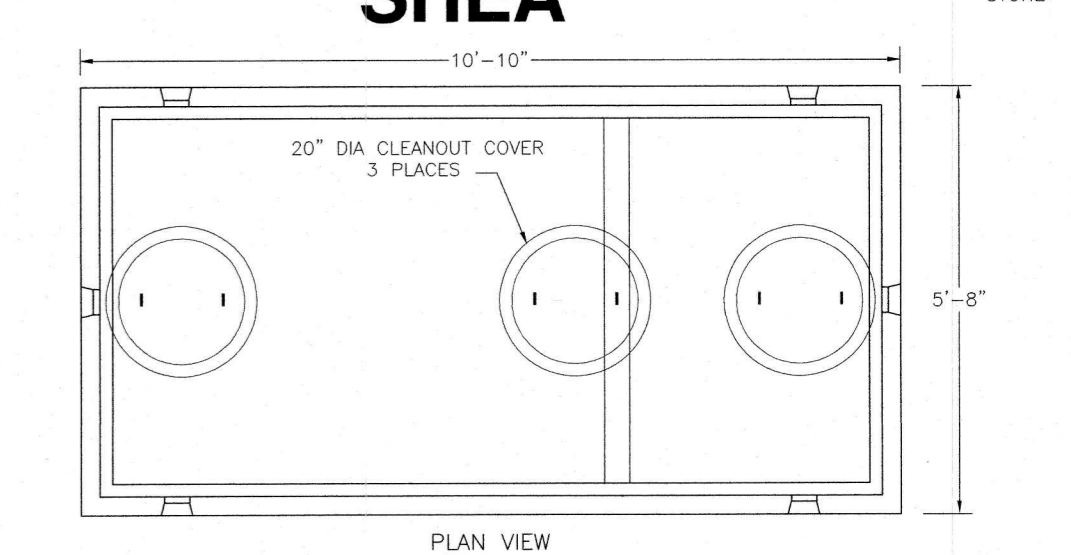

ITEM NO.	M1500	WEIGHT	11,035#
	M15002C		11,841#

### 1500 GALLON SEPTIC TANK MONOLITHIC 3" WALL N.T.S.

- CONCRETE: 4,000 PSI MINIMUM AFTER 28 DAYS.
- DESIGN CONFORMS WITH 310 CMP, SECTION 15.00 DEP TITLE 9 REGS FOR SEPTIC TANKS
- ALL REINFORCEMENT PER ASTM C1227.
- TEES AND GAS BAFFLE SOLD SEPARATELY.
- TONGUE AND GROOVE JOINT SEALED WITH BUTYL RESIN.
- IF COVER EXCEEDS 4 FEET, HEAVY DUTY TANK REQUIRED. ALSO AVAILABLE IN AASHTO HS-20 LOADING.