

LOCUS MAP
1"=1000'±

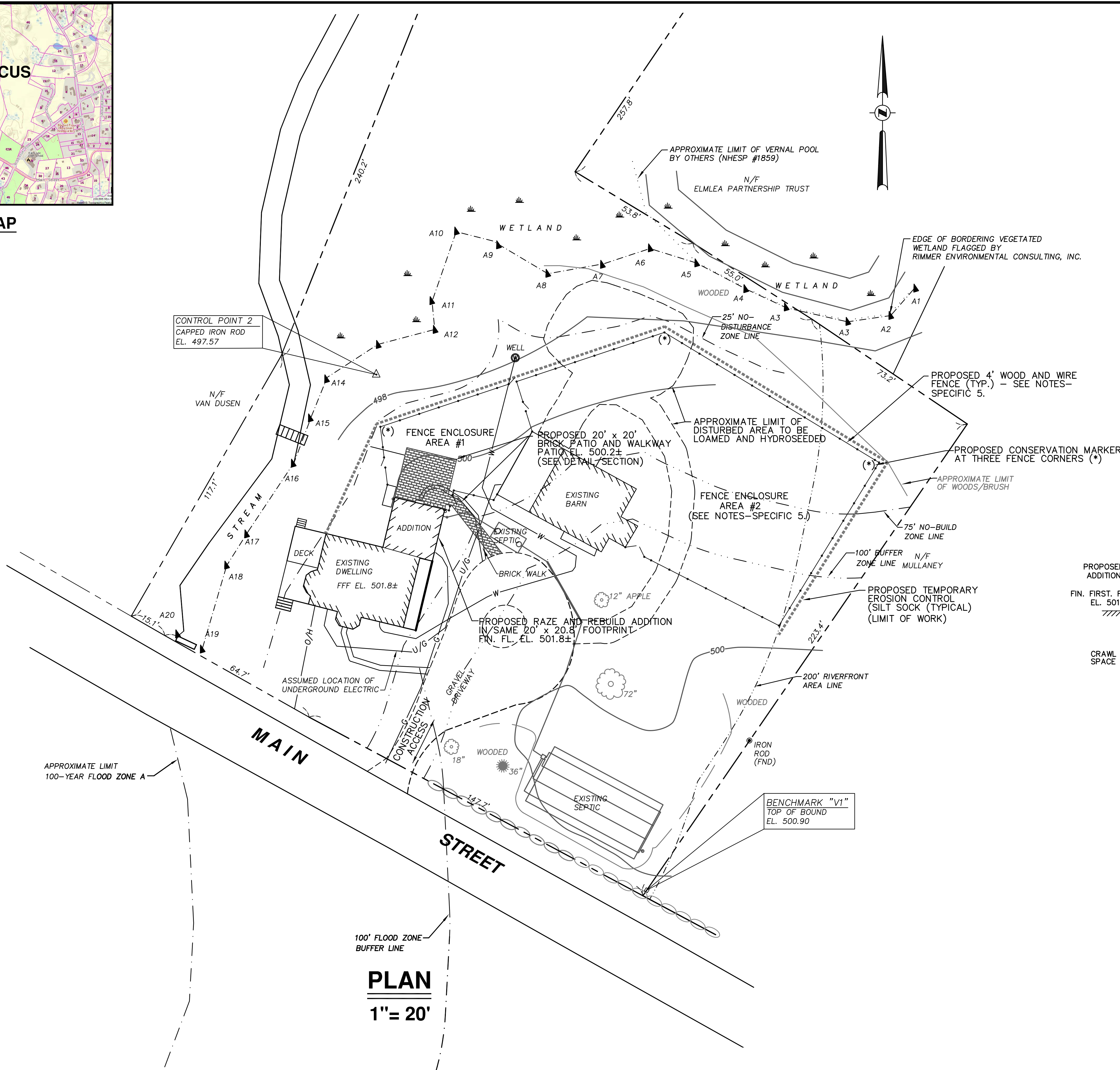

NOTES - SPECIFIC

- OWNER: ERIC CZERLONKA 77 MAIN STREET BOXFORD, MA 01921
APPLICANT: NORTHERN LIVE OAK DEVELOPMENT 149 SPOFFORD ROAD BOXFORD, MA 01921
- LOT BOUNDARIES DEPICTED HEREON ARE THE RESULT OF A BOUNDARY SURVEY AND DETERMINATION BY DONOHOE SURVEY, INC. SEE PLAN BOOK 472, PLAN 17.
- ASSESSORS DESIGNATION: PART OF MAP 28, BLOCK 1, LOT 2 AREA = 3.8± ACRES.
- TOPOGRAPHY SHOWN AS OF JULY, 2019. VERTICAL DATUM IS ASSUMED.
- FENCE ENCLOSURE AREA NOTES:
THE BOTTOM OF THE FENCE IN FENCE ENCLOSURE AREA #1 SHALL BE 4" ABOVE EXISTING GRADE
THE BOTTOM OF THE FENCE IN FENCE ENCLOSURE AREA #2 SHALL BE 6" ABOVE EXISTING GRADE
THE GATE BETWEEN THE TWO ENCLOSURE AREAS SHALL BE 6" ABOVE EXISTING GRADE

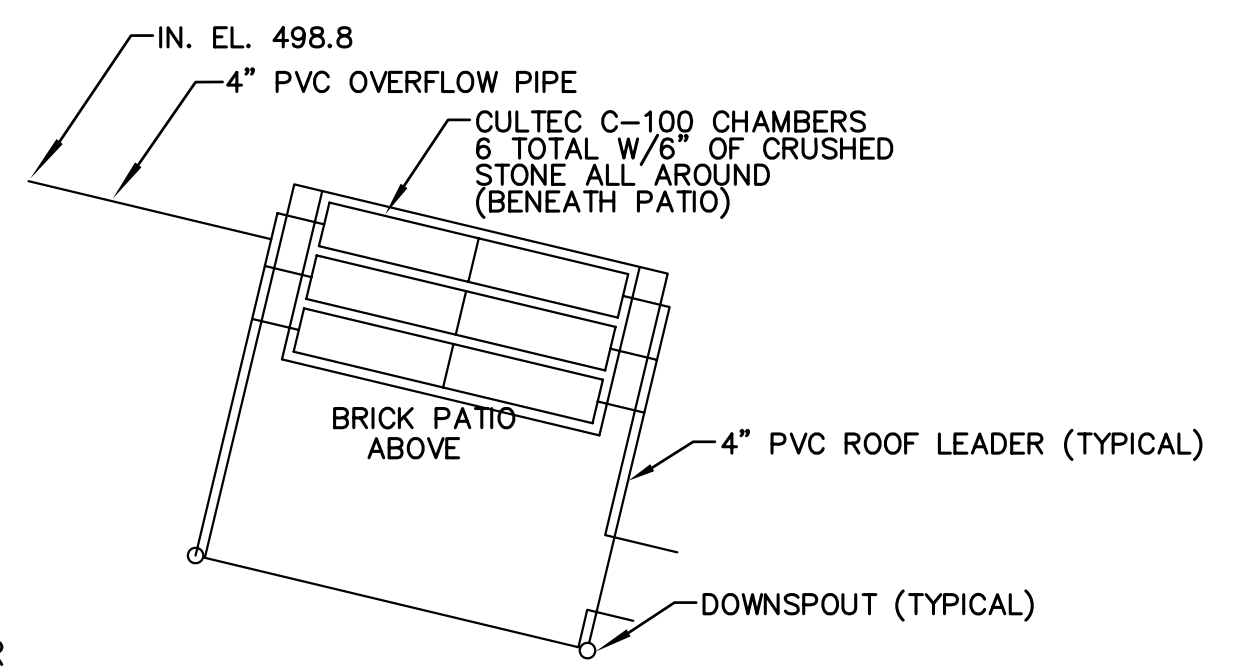

PATIO/INFILTRATION DETAIL
1" = 10'

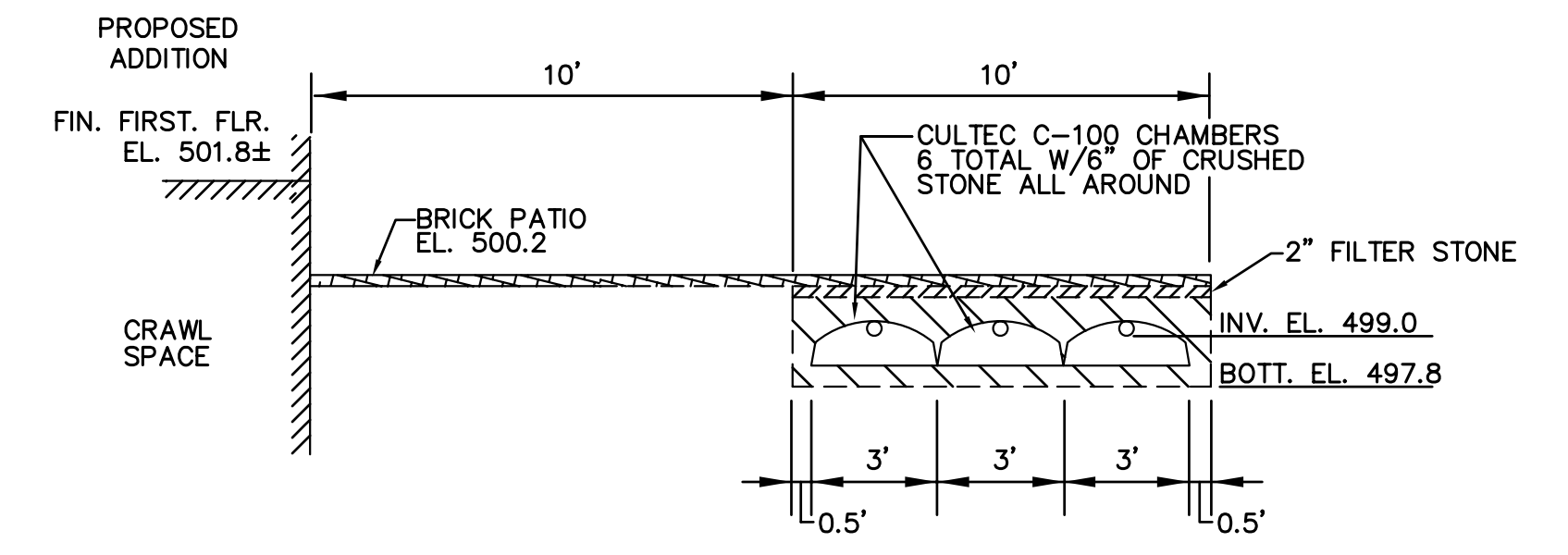

PATIO/INFILTRATION SECTION
NO SCALE

PERMIT PLAN
prepared for
NORTHERN LIVE OAK DEVELOPMENT

77 MAIN STREET BOXFORD, MA

GRAHAM ASSOCIATES, INC.
CIVIL ENGINEERS
TWO CENTRAL STREET, IPSWICH, MA 01938 (978) 356-2756

DRAWN BY: JC/GMM	CHECKED BY: HLG/GMM	PROJECT NO.: 19-1919-1
DATE: JUNE 22, 2022	SCALE: AS SHOWN	SHEET 1 OF 1

REVISION NO. 2: JULY 22, 2022 - ADDED FENCE ENCLOSURE AREAS AND NOTES
REVISION NO. 1: JULY 7, 2022 - ADDED DISTURBED AREA AND HYDROSEED NOTE