

SHEA New England's Premier Precaster
 CONCRETE PRODUCTS
 800-898-7433 (SHEA)
 WWW.SHEA-CONCRETE.COM
 BILLING ADDRESS: 87 HAVENHILL RD. AMESBURY MA 01813

SEPTIC TANK MONOLITHIC
 2000 GAL - 2 COMP

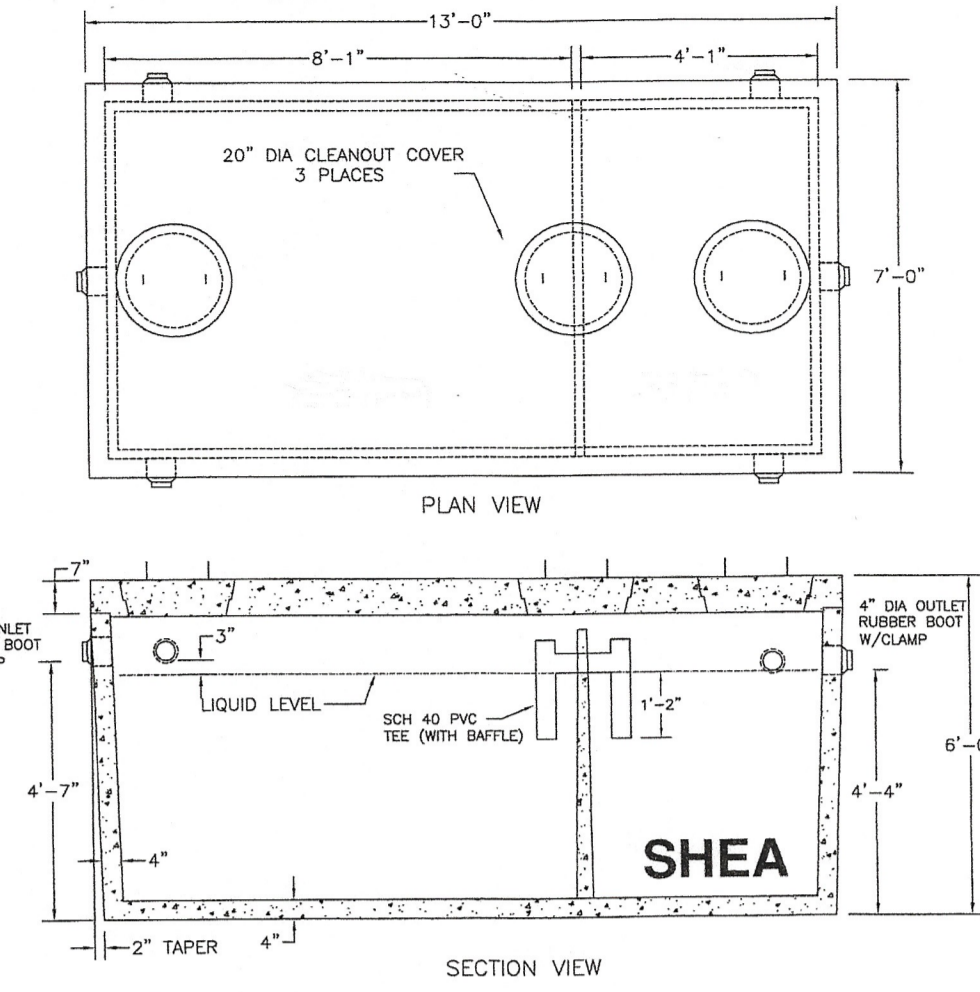

- NOTES:
1. CONCRETE: 4,000 PSI MINIMUM AFTER 28 DAYS.
 2. DESIGN CONFORMS WITH 310 CMR, SECTION 15.00 DEP TITLE 5 REGS FOR SEPTIC TANKS
 3. ALL REINFORCEMENT PER ASTM C1227.
 4. TEES AND GAS BAFFLE SOLD SEPARATELY.
 5. TONGUE & GROOVE JOINT SEALED WITH BUTYL RESIN.
 6. IF COVER EXCEEDS 4 FEET, HEAVY DUTY TANK REQUIRED. ALSO AVAILABLE IN AASHTO HS-20 LOADING.

SHEA PRODUCT NO. SEE TABLE	PREPARED FOR: [blank]	FILE NAME: HA220002C.dwg	DATE: 06/01/18	PAGE: 02.7	
WEIGHT LBS: SEE TABLE	DRAWN BY: ARD	DATE: 06/01/18	DATE: 06/01/18	DATE: 06/01/18	

SHEA New England's Premier Precaster
 CONCRETE PRODUCTS
 800-898-7433 (SHEA)
 WWW.SHEA-CONCRETE.COM
 BILLING ADDRESS: 87 HAVENHILL RD. AMESBURY MA 01813

DISTRIBUTION BOX
 9 OUTLET

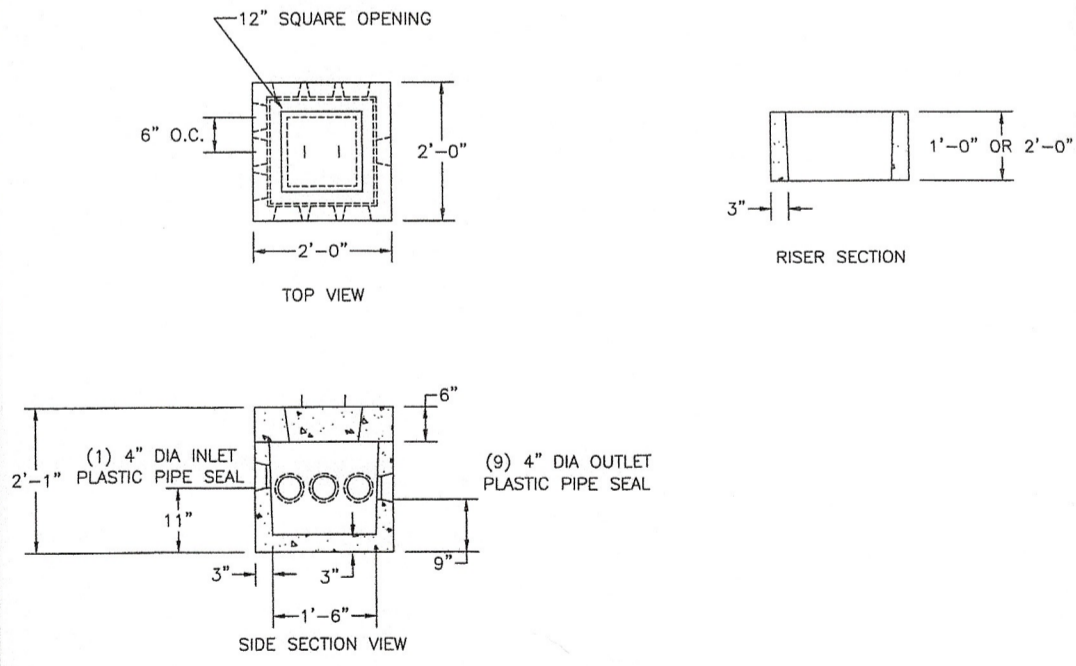

ITEM NO.	QTY	DESCRIPTION	WEIGHT
1	1	9" DIA. OUTLET PLASTIC PIPE SEAL	55.74
2	1	4" DIA. INLET PLASTIC PIPE SEAL	22.72
3	1	12" SQUARE OPENING	22.72
4	1	6" O.C. DIMENSION	22.72

- NOTES:
1. CONCRETE: 4,000 PSI MINIMUM AFTER 28 DAYS.
 2. DESIGN CONFORMS WITH 310 CMR, SECTION 15.000, DEP TITLE 5 REGS. FOR DISTRIBUTION BOXES.
 3. 9 OUTLET D-BOX DESIGNED FOR AASHTO HS-20 LOADING, COVER 1 TO 5 FEET.
 4. 9 OUTLET D-BOX OPTIONAL 18" ROUND OR SQUARE CAST IRON COVER AVAILABLE IN PLACE OF CONCRETE COVER.

SHEA PRODUCT NO. SEE TABLES	PREPARED FOR: [blank]	FILE NAME: db9out.dwg	DATE: 06/01/18	PAGE: 03	
WEIGHT LBS: SEE TABLES	DRAWN BY: ARD	DATE: 06/01/18	DATE: 06/01/18	DATE: 06/01/18	

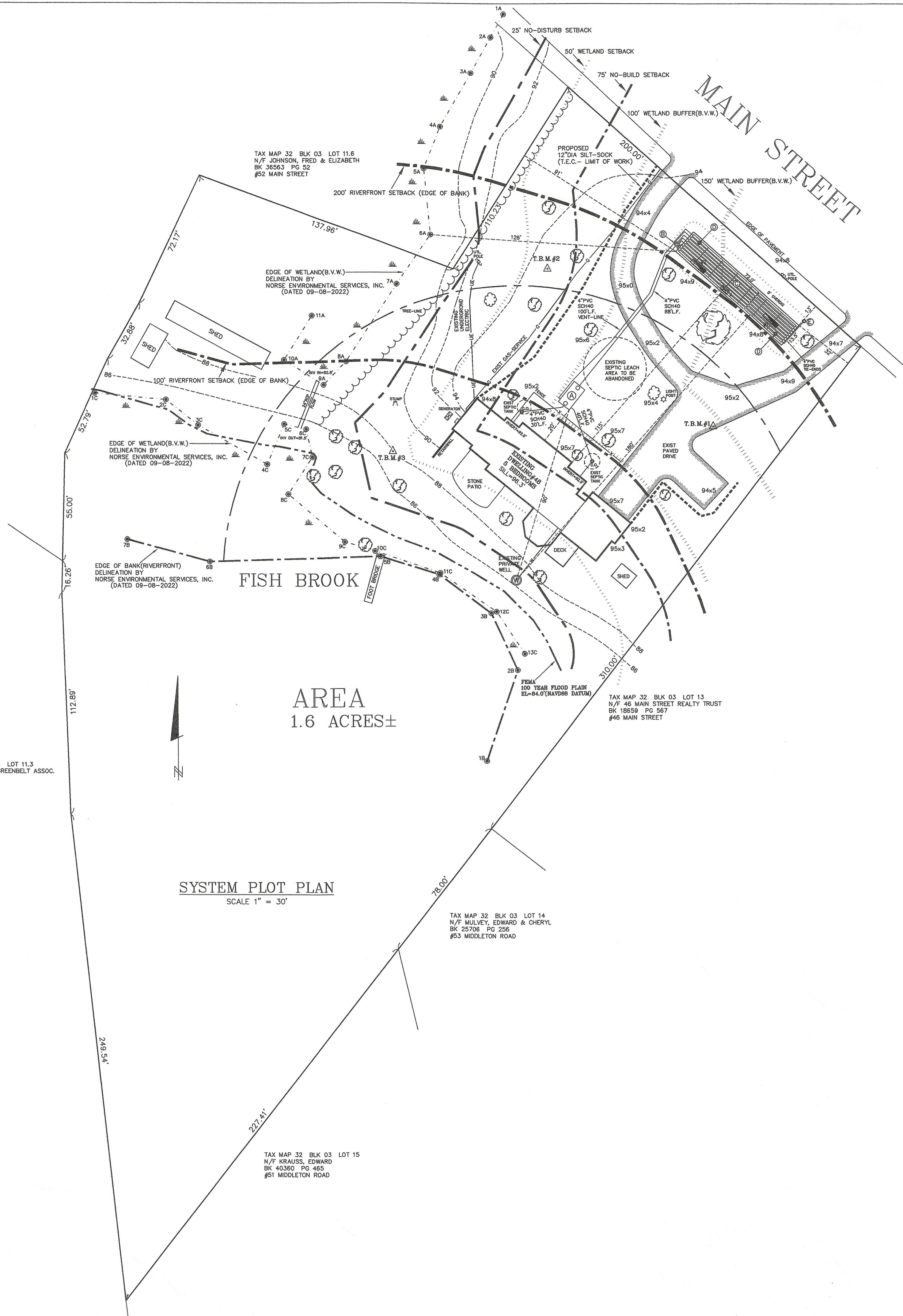

SYSTEM PLOT PLAN
 SCALE 1" = 30'

TAX MAP 32 BLK 03 LOT 11.3
 N/F ESSEX COUNTY GREENBELT ASSOC.
 BK 18198 PG 47
 HAYNES ROAD

TAX MAP 32 BLK 03 LOT 15
 N/F KRAUSS, EDWARD
 BK 40360 PG 465
 #51 MIDDLETON ROAD

TAX MAP 32 BLK 03 LOT 14
 N/F MULVEY, EDWARD & CHERYL
 BK 25708 PG 256
 #53 MIDDLETON ROAD

TAX MAP 32 BLK 03 LOT 13
 N/F 46 MAIN STREET REALTY TRUST
 BK 18659 PG 587
 #46 MAIN STREET

TRUSTEE: SHARON B. GLASS

OWNER: BRACKETT REALTY TRUST
 TAX MAP 32 BLK 03 LOT 12
 LOCUS DEED: BK 29126 PG 199

LOCATION: 48 MAIN STREET
 BOXFORD, MA 01921

Engineering Land Services, LLC
 P.O. BOX 41
 WEST NEWBURY, MA 01985

TEL: 978-815-6744 & FAX: 978-462-6800
 EMAIL: MASSPLSR@AOL.COM

SANITARY DISPOSAL
SYSTEM UPGRADE PLAN
 (REPAIR)

REVISIONS:

DRAWN: RMG
 CHECKED: SWB
 SCALE: AS NOTED
 DATE: 10-04-2022
 DWG NO. [blank]

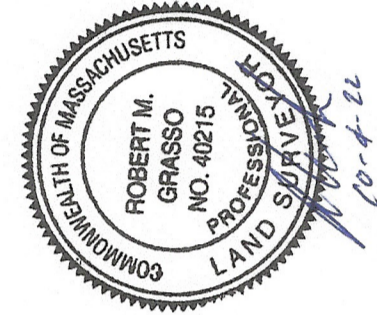
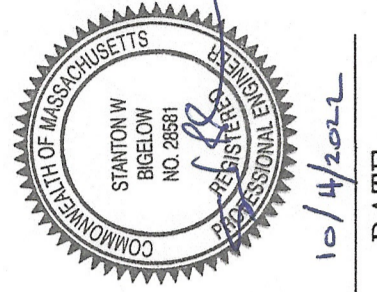

SHEET No. 3 OF 3