

LEGEND

EXISTING 2-FOOT CONTOUR	---	98
EXISTING 10-FOOT CONTOUR	---	100
EXISTING SPOT ELEVATION	1126	103.26
ISOLATED VEGETATED WETLAND	---	
VERNAL POOL	---	
25' NO DISTURB	---	
75' NO BUILD	---	
100' WETLAND BUFFER	---	
100' NO DISTURB FROM VERNAL POOL	---	
WELL	○	
DECIDUOUS TREE	○	
CONIFEROUS TREE	○	
CONCRETE	CONC.	
GARAGE FLOOR	G.F.	
WETLAND FLAG	WF	

ZONING DISTRICT: RESIDENCE - AGRICULTURAL DISTRICT (R-A)

MINIMUM LOT AREA = 2 ACRES
 MINIMUM LOT FRONTAGE = 250 FEET
 MINIMUM LOT WIDTH = 200 FEET
 FRONT YARD SETBACK = 50 FEET
 SIDE YARD SETBACK = 25 FEET
 REAR YARD SETBACK = 25 FEET
 MAXIMUM LOT COVERAGE = 25%

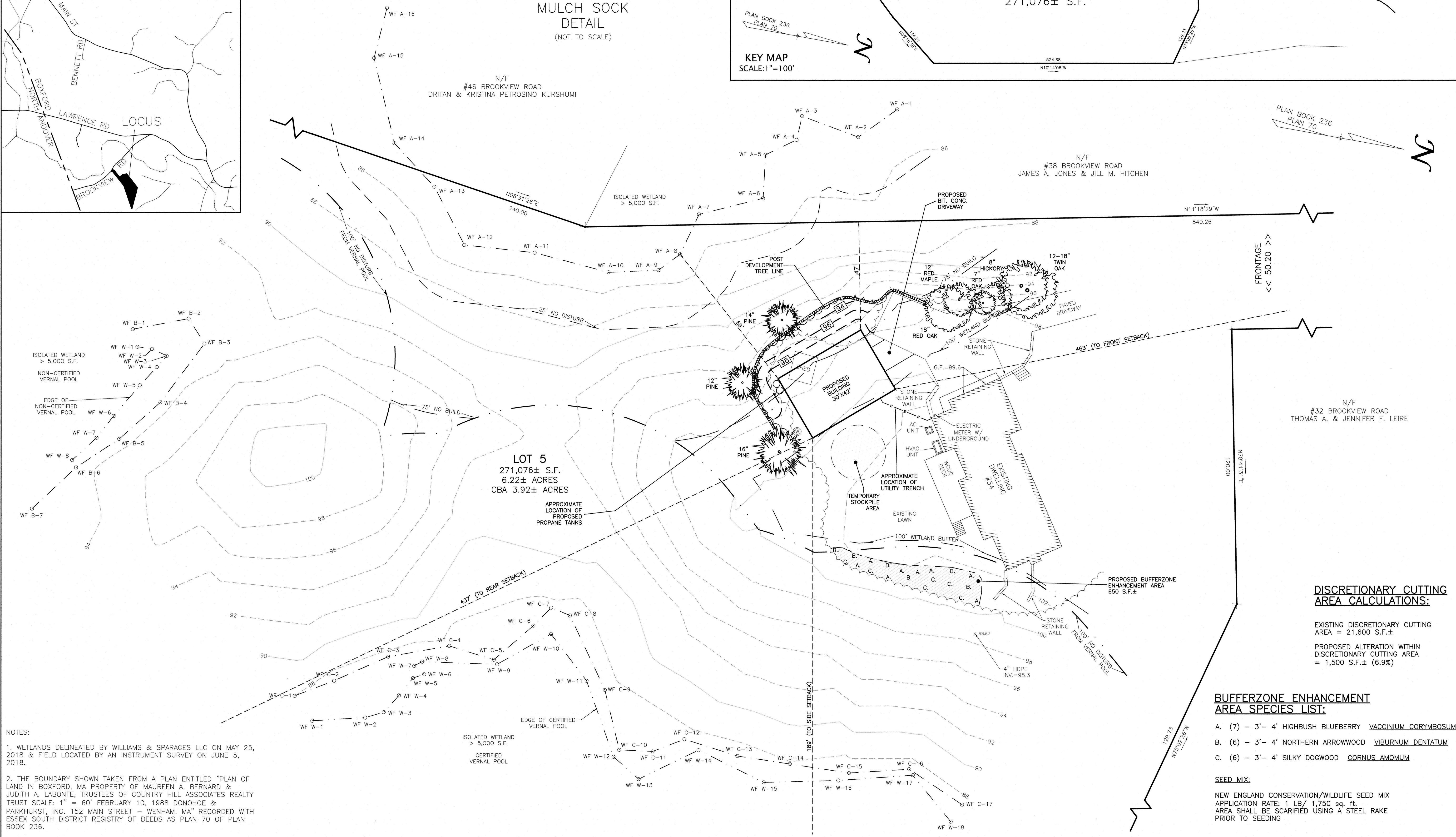
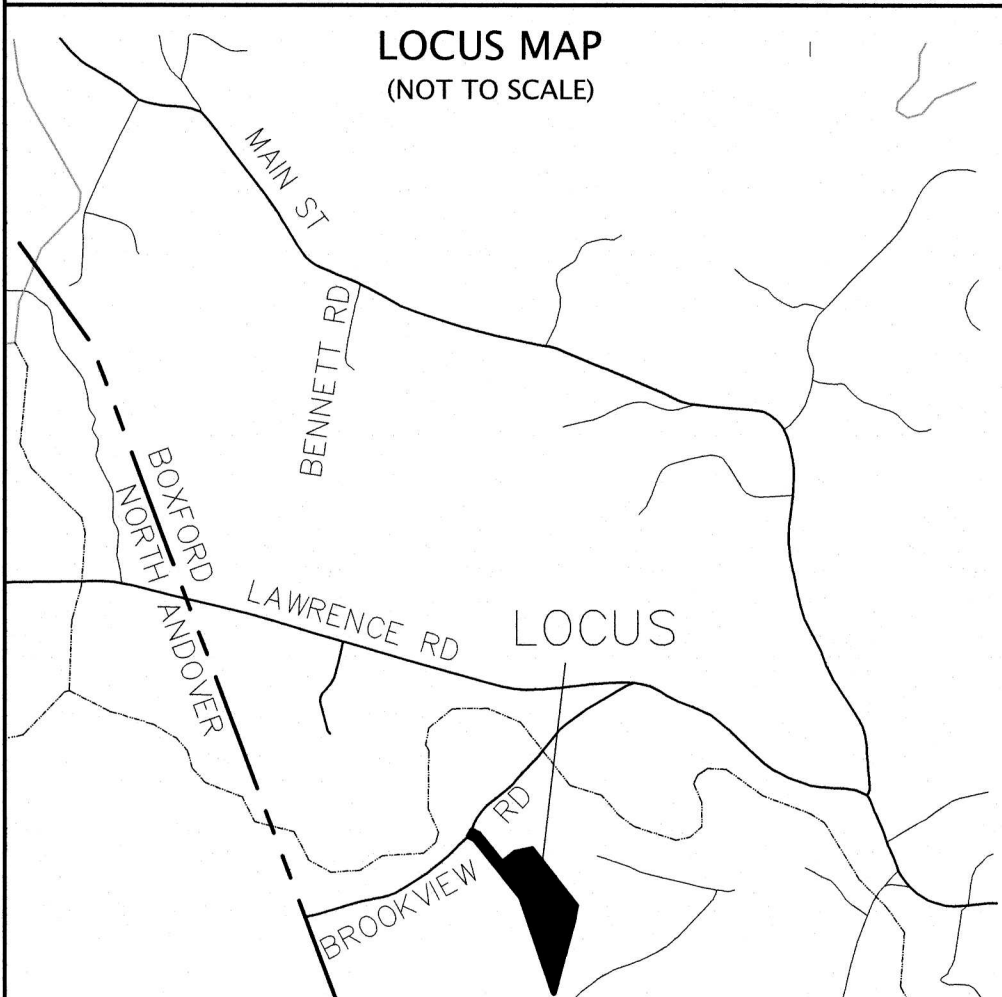
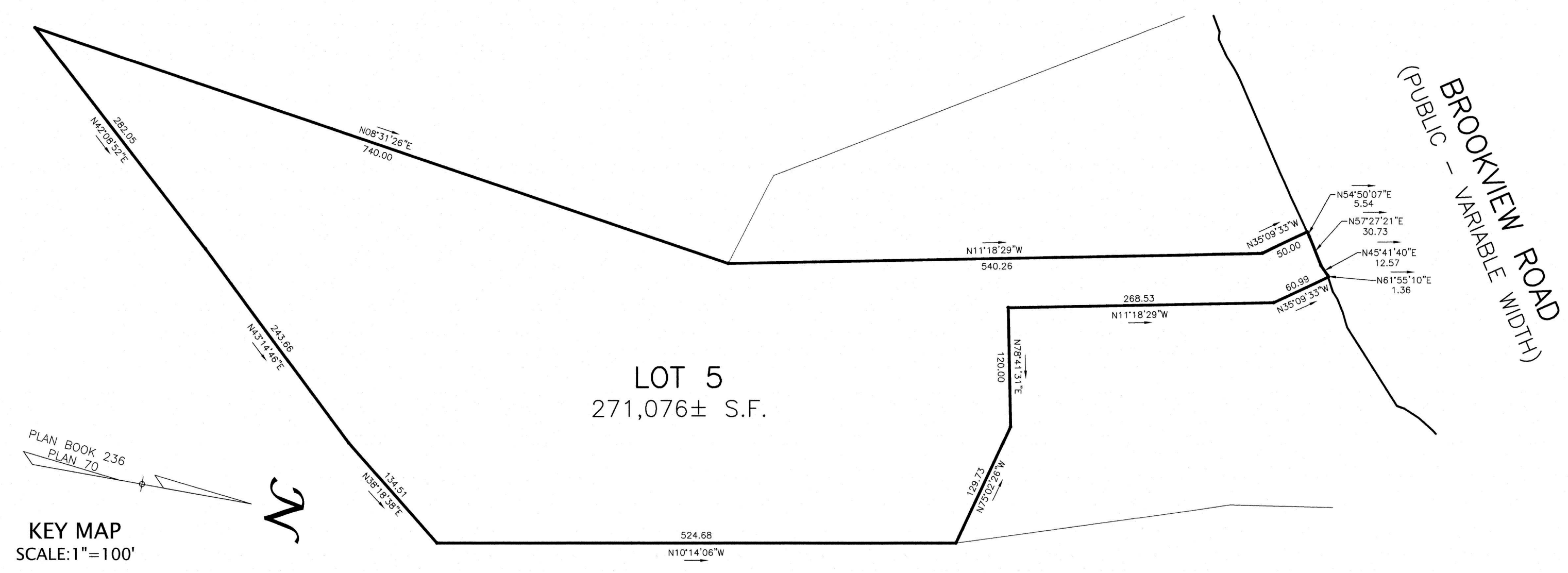
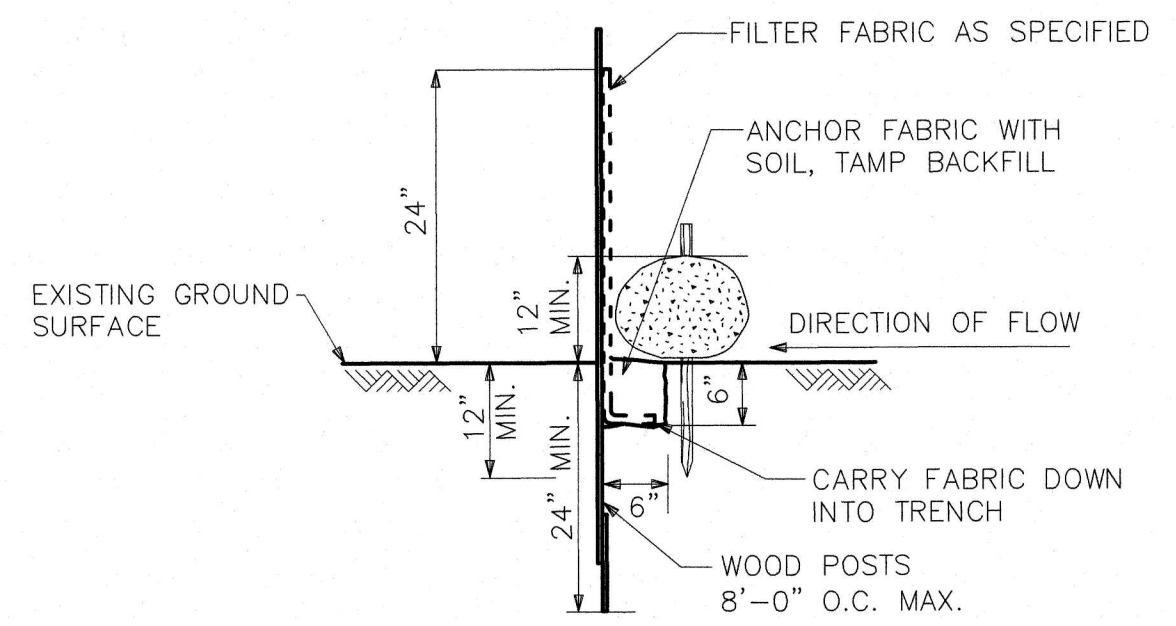

NOTES:

1. WETLANDS DELINEATED BY WILLIAMS & SPARAGES LLC ON MAY 25, 2018 & FIELD LOCATED BY AN INSTRUMENT SURVEY ON JUNE 5, 2018.
2. THE BOUNDARY SHOWN TAKEN FROM A PLAN ENTITLED "PLAN OF LAND IN BOXFORD, MA PROPERTY OF MAUREEN A. BERNARD & JUDITH A. LABONTE, TRUSTEES OF COUNTRY HILL ASSOCIATES REALTY TRUST SCALE: 1" = 60' FEBRUARY 10, 1988 DONOHUE & PARKHURST, INC. 152 MAIN STREET - WENHAM, MA" RECORDED WITH ESSEX SOUTH DISTRICT REGISTRY OF DEEDS AS PLAN 70 OF PLAN BOOK 236.

DISCRETIONARY CUTTING AREA CALCULATIONS:

EXISTING DISCRETIONARY CUTTING AREA = 21,600 S.F.±

PROPOSED ALTERATION WITHIN DISCRETIONARY CUTTING AREA = 1,500 S.F.± (6.9%)

- BUFFERZONE ENHANCEMENT AREA SPECIES LIST:**
- (7) - 3'- 4' HIGHBUSH BLUEBERRY *VACCINIUM CORYMBOSUM*
 - (6) - 3'- 4' NORTHERN ARROWWOOD *VIBURNUM DENTATUM*
 - (6) - 3'- 4' SILKY DOGWOOD *CORNUS AMOMUM*
- SEED MIX:**
- NEW ENGLAND CONSERVATION/WILDLIFE SEED MIX
 APPLICATION RATE: 1 LB/ 1,750 sq. ft.
 AREA SHALL BE SCARIFIED USING A STEEL RAKE PRIOR TO SEEDING

WILLIAMS & SPARAGES

ENGINEERS, PLANNERS, LANDSCAPE ARCHITECTS

101 MAIN STREET
 SUITE 101
 BOXFORD, MA 01750
 PHONE: (978) 336-8088
 FAX: (978) 336-8089
 WWW.WSENGINEERS.COM

Owner/Applicant:
 Oliver Parker McComas &
 Ursula A. McComas
 34 Brookview Road
 Boxford, MA 01921

Designed By: SML
 Drawn By: GJH
 Project Manager: CJH
 Job File Number: BOXF-0061
 Drawing File Folder: BOXF61

Drawing Issued for Review Only
 Drawing Issued for Permit
 Drawing Issued for Construction

SEAL

COMMONWEALTH OF MASSACHUSETTS

REGISTERED PROFESSIONAL CIVIL ENGINEER

WILLIAMS & SPARAGES

No. 40199

11/17/2021

PLAN TO ACCOMPANY A NOTICE OF INTENT

#34 BROOKVIEW ROAD, BOXFORD

REVISION	DATE	DESCRIPTION
6		
5		
4	11/17/2021	REVISED TO SHOW TREES TO BE REMOVED
3	10/1/2019	REVISED BUILDING LOCATION
2		REVISED PLAN PER BCC COMMENTS
1	6/11/2019	

DRAWING: EX-1

SHEET 1 OF 1

SCALE: 1" = 20'

MAY 2, 2019