

**LEGEND:**

- PAVEMENT EDGE
- TREELINE
- FENCE
- ⊙ 12" DT DECIDUOUS TREE
- ⊙ EXISTING CONTOUR
- \* LAMP
- ⊙ PROPANE TANK
- ⊙ WELL
- (114) PROPOSED CONTOUR
- PROPOSED LIMIT OF CLEARING
- PROPOSED RETAINING WALL
- PROPOSED EROSION & SEDIMENTATION CONTROL BARRIER

- NOTES:**
1. WETLANDS WERE DELINEATED BY MAUREEN HERALD NORSE ENVIRONMENTAL SERVICES, INC. IN MARCH 2022 AND LOCATED BY ANDOVER CONSULTANTS, INC. VIA AN INSTRUMENT SURVEY.
  2. THE PURPOSE OF THIS PROJECT IS TO CONSTRUCT A POOL WITH SURROUNDING PATIO, POOL HOUSE/SHED AND ASSOCIATED GRADING TO FLATTEN A SMALL AREA AROUND THE POOL HOUSE/SHED. ONLY A SMALL PORTION (265 SF) OF THE PATIO WILL BE WITHIN THE 100' BUFFER AND THE PROPOSED POOL HOUSE/SHED WILL BE 85' FROM THE BVW. ADDITIONALLY AN EXISTING SHED THAT IS 67' FROM THE BVW WILL BE REMOVED AS PART OF THIS PROJECT.

**OWNER/APPLICANT:**  
SUNDAR NARASIMHAN & MARIE LAMB  
28 PINE PLAIN ROAD  
BOXFORD, MA

**DEED REFERENCE:**  
DEED BOOK 13787, PAGE 578

**ASSESSOR REFERENCE:**  
TOWN MAP NO. 11, BLOCK NO. 2, TOWN LOT NO. 23

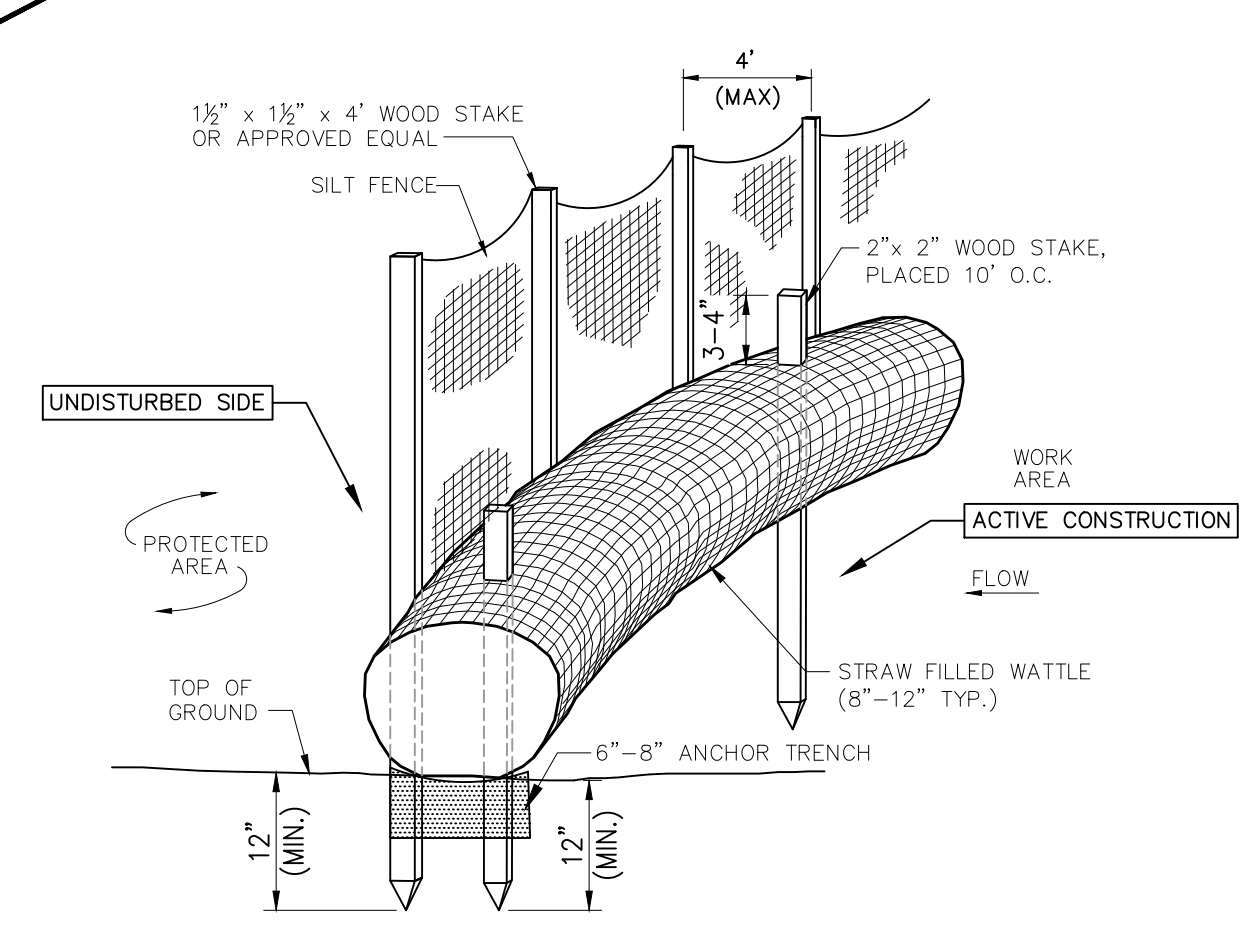

**NOI PROPOSED SITE PLAN**  
**28 PINE PLAIN ROAD**  
**BOXFORD, MASS.**

PREPARED FOR: MARIE LAMB & SUNDAR NARASIMHAN  
DATE: MAY 15, 2023  
SCALE: 1"=20'

**andover consultants inc.**  
1 East River Place  
Methuen, Mass. 01844  
Telephone: 978-687-3828

DENNIS A. ORRECCI  
CIVIL  
No. 49318  
REGISTERED PROFESSIONAL ENGINEER

Reg. Prof. Engineer

0 20 40 60 80 Ft.  
0 5 10 20 Meter