



BOXFORD SELECT BOARD

Monday, May 8, 2023

Town Hall 7A Spofford Road

Meeting Room 1

Remote option through Zoom:

<https://us02web.zoom.us/j/8157412201?pwd=WFIUWU1PS1c2NGNuZUJ3TERNbWpRQT09>

AGENDA

This meeting is audio and video recorded

7:00 PM Call to Order

7:05 PM Announcements

7:10 PM Consider Appointment of Registrar of Voters

- Kenneth Lee Thompson

7:15 PM Report of the Town Administrator

- Discussion of proposed dry hydrant within Willow Road right of way
- Consider approval of Memorandum of Agreement for new Collective Bargaining Agreement, Teamster Local 25 Boxford Police Patrol Officers
- Consider approval of Memorandum of Agreement for new Collective Bargaining Agreement, Boxford Police Reserve Association
- Common Victualer's License, Stone House Farm, Inc., 276 Washington Street
- Any other business to come before the Town Administrator and the Board not anticipated at the time of this posting

7:35 PM Discussion on May 9, 2023 Town Meeting

8:00 PM Routines

- Correspondence
- Appointments
- Approval of Minutes
- School and Non-School Warrants

8:05 PM Any other business to come before the Board

Adjourn

Next Meeting – May 22, 2023

New Call to Order

I call this meeting to order and inform all that this meeting is being video and audio recorded.

Pursuant to Chapter 2 of the Acts of 2023, this meeting will be conducted via remote hybrid means, in accordance with applicable law. This means that members of the public body as well as members of the public may access this meeting via virtual means in addition to in person through the remote participation link provided on this meeting's posting on the Town's website calendar. The website calendar also lists the specific ID number required for virtual attendance via Zoom along with phone numbers to dial into the meeting.

Additionally, the public is able to: Listen to and/or view this meeting via BCATv on FIOS channel #39 or Comcast Channel #22 or through the BCATv website; OR Participate in the meeting virtually.

Members please be aware that, if at least one member attends the meeting remotely, all votes must be roll call votes.

ANNUAL TOWN MEETING AND ELECTION

Boxford's Annual Town Meeting will take place on May 9, 2023 at 7pm in the Masconomet Auditorium, 20 Endicott Road.

Residents can access the Annual Town Meeting Warrant and supporting materials for each of the articles on the Town of Boxford website at www.boxfordma.gov/TownMeeting2023

The Annual Town Election will occur on May 16 at Town Hall, 7A Spofford Road from 7am until 8pm. The last day to register to vote (if you are not already registered) is April 30.

Registration may be accomplished online by going to online to the Secretary of the State's webpage at www.sec.state.ma.us or in person at the Town Clerk's office in Town Hall.



Town of Boxford

Community Workshops

We want to hear from you!

We are Studio Luz Architects and we are working with the Town of Boxford and MassDevelopment to create a new vision for two surplus properties located at 4 Middleton Road and 188 Washington Street that will benefit the surrounding Boxford community. We want to hear your thoughts. What would you like to see happen at 188 Washington Street and 4 Middleton Road?

This new vision for 4 Middleton Road and 188 Washington Street will be based off community input, market analysis and the programmatic needs of the town, defining the future programming and connecting the vision to the Boxford Town Facility master plan and Town Meeting cycle.

The goal is to develop consensus for future use of 4 Middleton Street and 188 Washington Street and produce comprehensive documentation of programming scenarios to inform a subsequent Request for Proposals for the redevelopment of the property for the new proposed use.

Please join us at our in-person and virtual workshops!

05/15

In-Person

Visioning Workshop

7:00 pm-8:00 pm

10 Elm Street, Boxford, MA

05/18

Virtual

Visioning Workshop

7:00 pm-8:00 pm

Zoom Meeting

Scan here for
more information

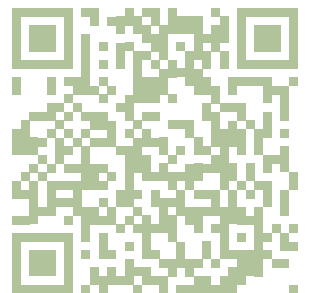

Town of
Boxford
Massachusetts

MassDevelopment

STU
DIO
LUZ
ARCHITECTS

www.boxfordma.gov/VillageCenters

From: [Robin Phelan](#)
To: [Matt Coogan](#)
Subject: appointment of Ken Thompson to Board of Registrars
Date: Thursday, May 4, 2023 1:42:46 PM

Hi, Matt. The Democratic Town Committee has recommended that Kenneth Lee Thompson be appointed to the Board of Registrars by the Boxford Select Board. Thanks.

Robin Phelan

Town Clerk

TOWN OF BOXFORD

7A Spofford Road

Boxford, MA 01921

Telephone (978) 887-0710

Fax (978) 887-0943

rphelan@town.boxford.ma.us

Please note that the Secretary of State has determined that every record, including email, made or received by a public entity is presumed to be a public record.

From: [Ross Povenmire](#)
To: [Matt Coogan](#)
Cc: [Ted Merchant](#); [Brian Geiger](#); [Christopher Olbrot](#); [Daniel Wells](#); [Peter Delaney](#)
Subject: Request for agenda item on May 8 Select Board meeting
Date: Wednesday, May 3, 2023 9:50:43 AM

Hello Matt, as discussed, the ZBA imposed a condition on the Special Permit for the Willows at Boxford, at the behest of the Boxford Fire Department, for a dry hydrant to be installed prior to the issuance of a certificate of occupancy for the new dwellings. An initial proposal by Toll Bros., Inc. to place a dry hydrant within the Conservation Restriction (CR) area of the Willows at Boxford property was rebuffed by the ConsCom as being inconsistent with the intent and language of the CR. There is no alternative for a dry hydrant within the Willows at Boxford property outside of the CR area.

An alternative proposal to place a dry hydrant on Willow Road in the vicinity of the Parker River crossing has been developed by Toll Bros., Inc. This alternative was discussed informally at a meeting of relevant department heads, including the Fire Chief, and was agreed by all to be a possible solution to the seeming impasse.

Toll Bros., Inc. has prepared plans and will prepare a Notice of Intent for the required ConsCom approval. Because the work is entirely within the road right-of-way, the NOI will require the signature of the Select Board Chair as the property owner. Toll Bros., Inc. will sign the NOI as the applicant. This is similar to what was done for the recent application for the truck spill clean-up.

Please place this matter on the agenda for Monday, May 8, so that the necessary signature can be obtained. Arrangements are being made to have a hard copy of the NOI to you in time for the Monday night meeting. Thank you.

Ross

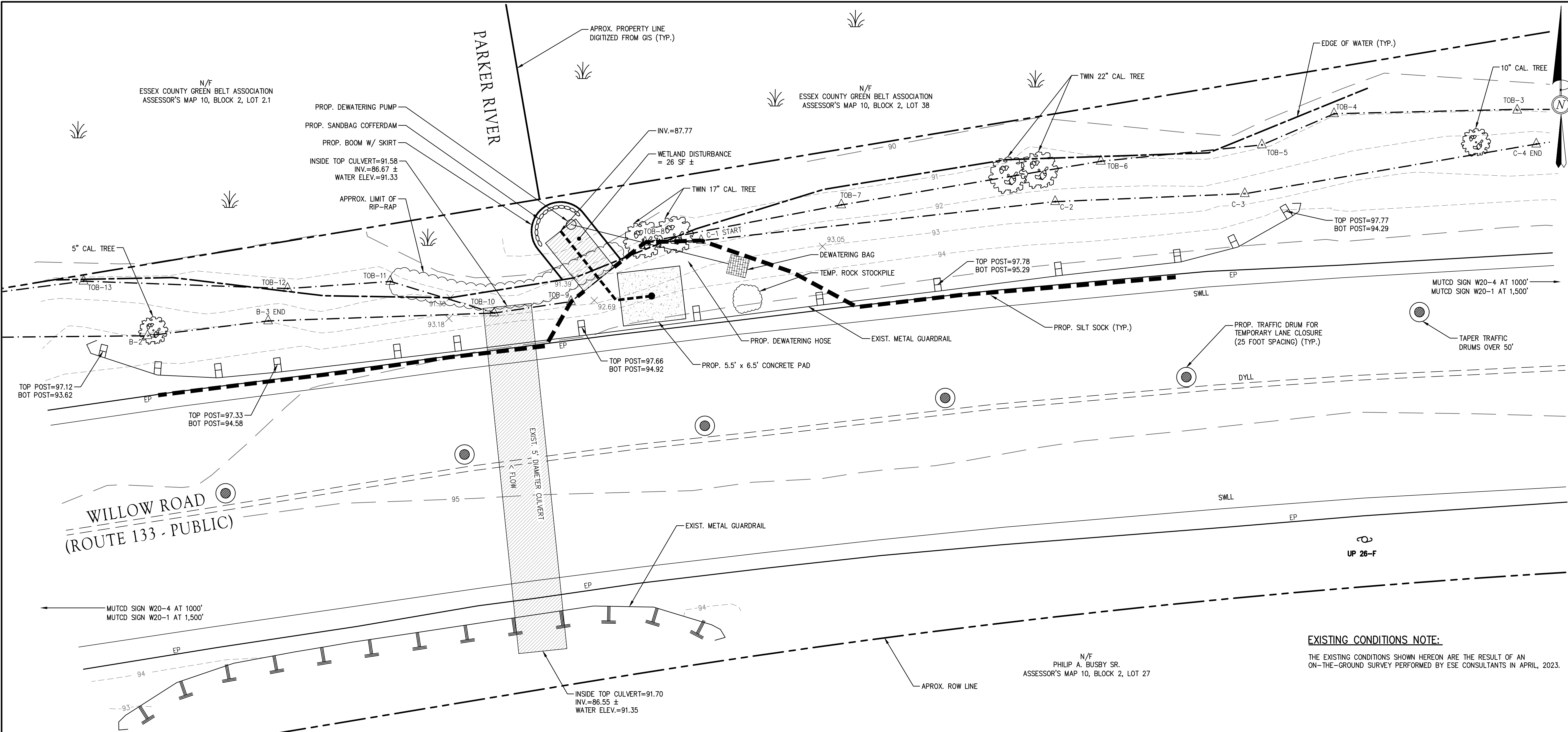

The Morin-Cameron GROUP, INC.

CIVIL ENGINEERS / ENVIRONMENTAL CONSULTANTS
LAND SURVEYORS / LAND USE PLANNERS
66 ELM STREET, DANVERS, MASSACHUSETTS 01923
P: 978-777-5886, F: 978-774-5486, W: WWW.MORINCAMERON.COM

DRAFT

SURVEY BY: ESE
DRAFTED BY: EMB
CHECKED BY: SPC
APPROVED BY: SPC
SCALE: 1" = 20'
DATE: APRIL 20, 2023

NO.	REVISIONS	DESCRIPTION	DATE

PLAN TO ACCOMPANY NOTICE OF INTENT
IN
BOXFORD, MASSACHUSETTS
WILLOW ROAD
PREPARED FOR
TOWN OF BOXFORD

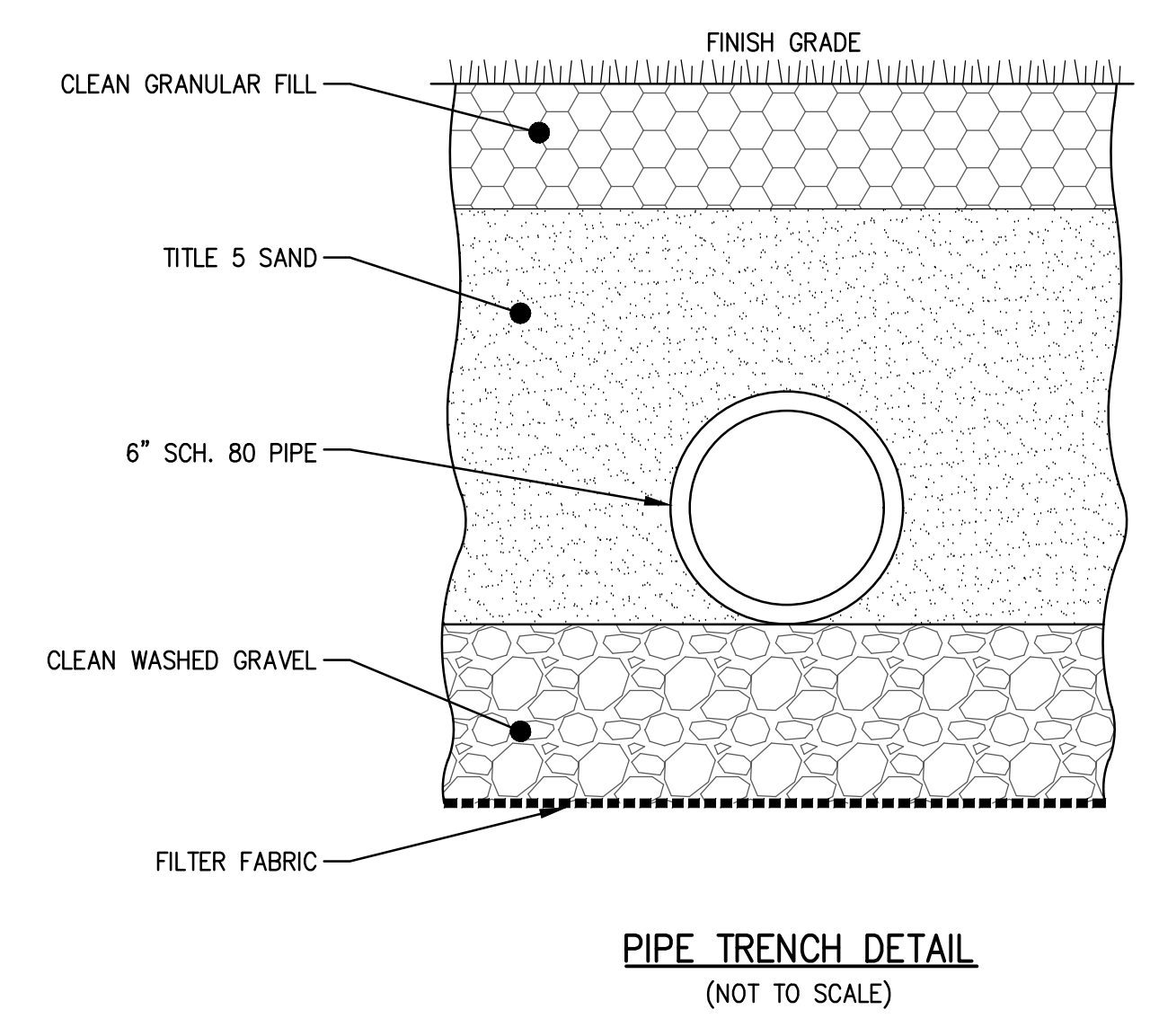
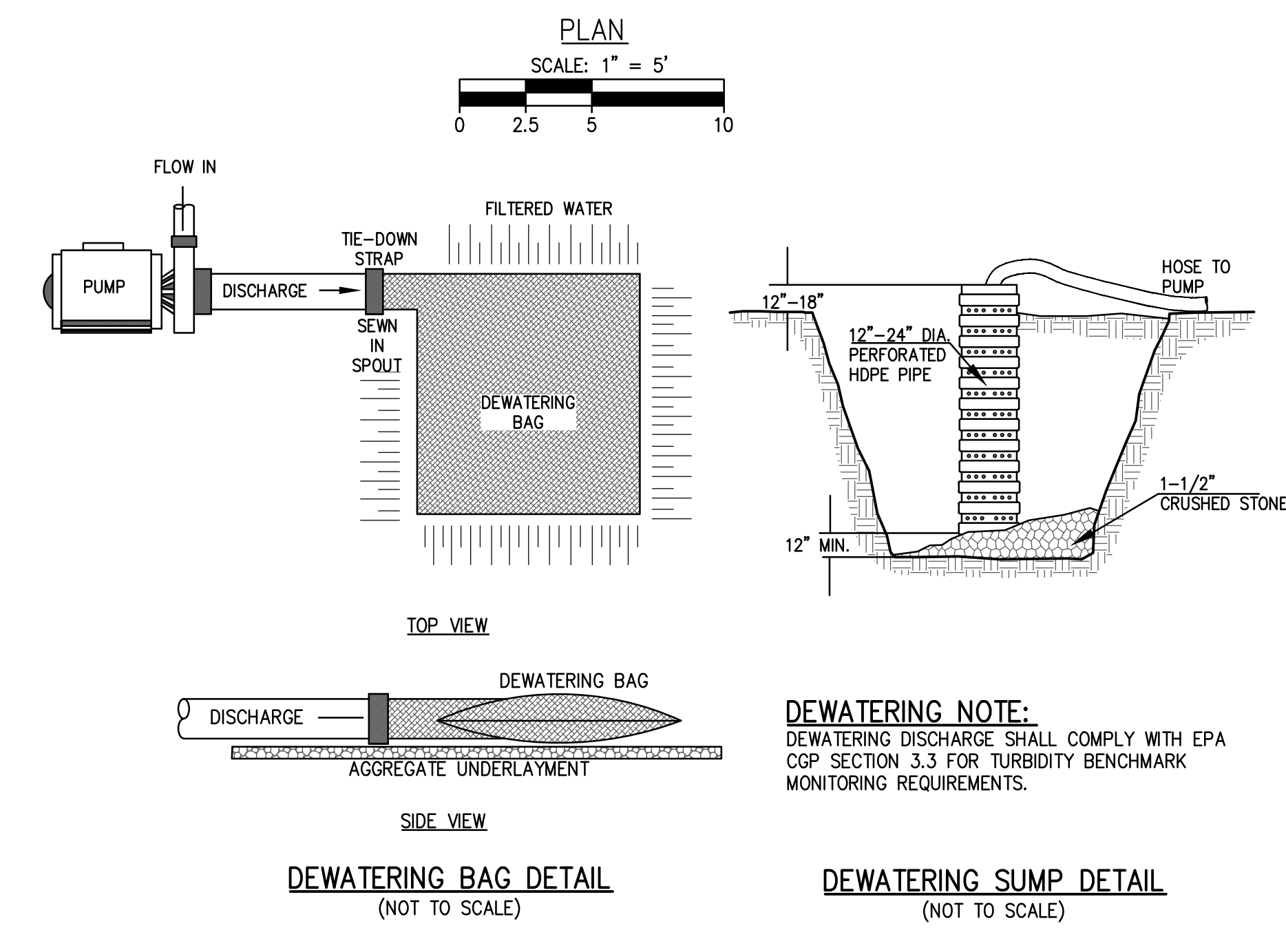
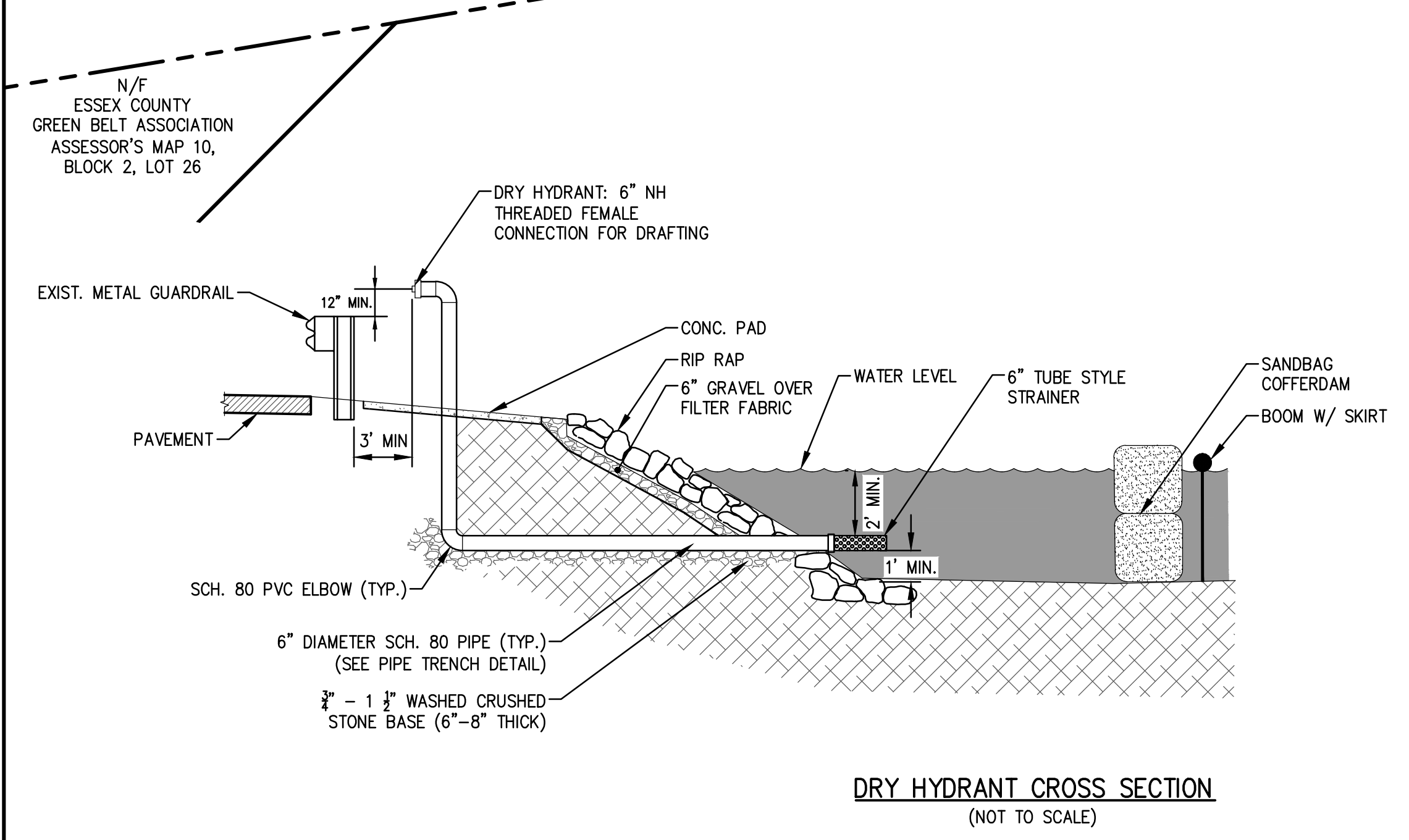

DEWATERING NOTE:
DEWATERING DISCHARGE SHALL COMPLY WITH EPA CGP SECTION 3.3 FOR TURBIDITY BENCHMARK MONITORING REQUIREMENTS.

MEMORANDUM OF AGREEMENT
Between
Teamsters Local 25 Boxford Police Patrol Officers
&
Town of Boxford

July 1, 2023 – June 30, 2026

Upon ratification, the following are agreed upon changes or additions to the existing agreement with an expiration date of June 30, 2023:

1. Article 9 “Grievance Procedure and Arbitration” p. 7

Make the following changes to this Article:

Section 1. The term "grievance" shall mean any dispute concerning the interpretation, application, enforcement, violation or meaning of this ~~agreement~~ **Collective Bargaining Agreement.**

Section 2. Any grievance that falls within the jurisdiction of the Chief of Police shall be submitted first to the Chief by Local 25 or a member of Local 25 and an earnest effort shall be made by a member of Local 25 and the Chief to adjust the grievance in an informal manner. If the grievance is such that it cannot be adjusted within ~~forty-eight (48) hours~~ **5 days** after the same has been submitted to the Chief of Police, then the matter shall be submitted to the Board of Selectmen of the Town in accordance with the following procedure:

C. If the Board takes no action within the fourteen (14) day period after the grievance has been submitted to it in writing, or, if Local 25 or member of Local 25 is not satisfied with the Board's decision, **within 10 days of receipt of such decision,** then the matter shall be referred to the American Arbitration Association for the selection of an arbitrator for the submission to final and binding arbitration in accordance with the provisions of Section 8 and Section 9 of General Laws Chapter 150E.

2. Article 10 – Clothing, Allowance and Equipment

Add: Section 5- All officers shall have the option to wear external load bearing vest carriers.

3. Article 11 “Holidays” p. 8

Add Juneteenth to list of holidays.

4. Article 15 “Hours of Work and Overtime”

Section 5: Define “continuing sickness or injury” as an illness or injury lasting more than 20 consecutive work shifts.

Section 12: Increase annual cap on compensatory time to 120 hours.

Section 13 (p. 12): delete B:

B. The parties agree, if so requested by the Union in writing during the third year of the contract (i.e. FY23), to re-open only Section 12 of this Article to negotiate potential changes to the compensatory time bank. Neither party is obligated to reach an agreement if this item is re-opened.

5. Article 19 “Paying Police Details”

Change rate of private details to \$64 per hour

Change rate of town details to \$54 per hour

Add Strike/ Word Stoppage Details \$120.00, but this section would not apply to striking by Town employees, including the Masconomet Regional School District employees. Town rate would apply.

Add: Private details will be charged at 4 hours of the applicable rate if the private company cancels their detail 2 hour or less from the scheduled start time of the detail.

Add Paragraph:

The Town of Boxford has the right to withhold detail hours from the payroll system under the following circumstances:

- Out-of-town details worked for companies that have overdue invoices and/ or missing or incomplete billing information from the officer who worked the detail.
- Private, in-town details that are missing or have incomplete billing information.

Strike final sentence “The Town shall maintain a fund of \$1,000.00 from which to make prompt payments to members pending collection of payments.”

6. Article 20 Pay Matrix

Increase base salaries by 2% in each of the contract years.

7. Article 23 “Job Security” p. 15

Language change to 2nd paragraph: A Full-time ~~patrolmen~~ patrol officer shall be required to confirm with departmental regulations established or hereinafter established shall be expect to always conduct ~~himself~~ themselves in a manner betting a police officer of the Town of Boxford, whether ~~in or out of uniform~~ on or off duty.

Language change to 3rd paragraph: Strike “A Probationary Patrol Officer” in 1st sentence.

Language change to 4th paragraph, 1st sentence “A Full-Time Patrol officer may be suspended with without pay if is he/she is charged with a commission of a felony indicted of a felony.”

8. New: Accreditation

Town agrees to the following one-time base salary increases in terms of achieving State Certification and Accreditation:

Year1- 1%, Year 2-1%, Year 3- 1%

9. New: Performance Review:

Both parties agree to the Boxford Police Department implementing a program where union members set goals with their supervisors and are evaluated annually at a minimum. It is understood that the program shall not be used for discipline of any kind.

10. New: Global Position Device, In Car Video

As part of this agreement, it is understood that, in Fiscal Year 2024, the Boxford Police Department will be utilizing a Global Position (GPS) Device within the Mobile Data Terminals of all town-owned police vehicles as part of the implementation of ProPhoenix, the Town’s new Computer Aided Dispatch (CAD) Records Management Software (RMS). It is understood that disciplinary actions against and excessive monitoring of employees is neither the primary purpose nor the intended result of the implementation of the GPS system.

As part of this agreement, it is understood that the Town of Boxford and the Boxford Police Department will install and activate an interior video camera/recorder, commonly referred to as “dash cameras”, in any or all town owned vehicles. It is understood that disciplinary actions against and excessive monitoring of employees is neither the primary purpose nor the intended result of the implementation of a dash camera system.

11. General

Replace “Selectmen” with “Select Board” throughout contract

Make contract gender neutral (he/she, his/her, patrol officer, etc.)

Town of Boxford

Local 25 Boxford Police Patrol Officers



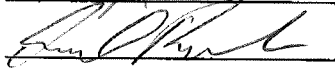

Date: _____

Date: 5/4/23

**Agreement of Contract Extension and Modification
of the Collective Bargaining Agreement
By and Between
Town of Boxford and
The Boxford Police Reserve Association**

July 1, 2023 – June 30, 2024

Now comes the Town of Boxford hereinafter referred to as the (“Town”) and the Boxford Police Reserve Association hereinafter referred to as the (“Association”) collectively referred to as the (“Parties”).

WITNESSETH

1. WHEREAS the Parties entered in a three (3) year Collective Bargaining Agreement dated from July 1, 2020 through June 30th 2023 hereinafter (“Agreement”) on or about June 15th 2021 and subsequently ratified at the Boxford Annual Town Meeting on or about June 26, 2021, and subsequently executed by the Town Administrator on or about August 1st, 2021, with an expiration on or about of June 30th, 2023 incorporated by reference herein and marked as Exhibit “A”.
2. WHEREAS, the Parties in good faith mutually agree to extend and modify the Agreement with this successor Agreement of Contract Extension and Modification hereinafter (“Extension Agreement”) subject to the terms and conditions as stated herein.

NOW THEREFORE, the Parties agree to the following terms and conditions as stated herein:

3. **Amend Article 4 – Term of Agreement.** The Parties agree to a one-year successor Extension Agreement term commencing from July 1, 2023 through June 30, 2024.
4. **Amend Article 17 – Rate of Compensation:** The Parties agree to amend Article 17 with respect to a base wage increase of two percent (2%) effective as of and commencing on July 1, 2023 without delay and or offset. See attached Rate of Compensation Matrix incorporated by reference herein as Exhibit (“B”).
5. The Parties agree to commence good faith Collective Bargaining talks for the next contract term on or before December 1, 2023 and shall use good faith efforts to complete the same on or before March 31st 2024.
6. The Parties agree all other terms and conditions stated within Agreement and not modified pursuant to this Extension Agreement shall remain in full force and effect.
7. This Extension Agreement is subject to and conditioned upon ratification by the Board of Selectmen of the Town of Boxford and funding by the Town of Boxford on or before May 9th 2023 and subject to ratification by the Union membership of the Association, all of which shall not be unreasonably withheld by the Parties.

8. This Extension Agreement is duly executed by the authorized representative(s) of the Town of Boxford and Boxford Police Reserve Association respectively and the Parties represent and warrant they have the respective authority to enter into this Extension Agreement.

Whereby the Parties hereto sign under Seal.

Town Boxford

Boxford Police Reserve Association



Matthew Coogan
Town Administrator
Date:

Albert P. Manzi III, Esquire
President
Date: May 4th, 2023

Board of Selectmen

/s/ Peter Cheverie

Barbara G. Jessel, Chair
Date:

Peter Cheverie
1st Vice President

/s/ Eric Renda

Charles J. Costello, Clerk

Eric Renda
Treasurer

/s/ Michael S. Dougherty

Peter C. Perkins

Michael S. Dougherty
Secretary

Judith A. Stickney

Margaret Chow-Menzer

EXHIBIT "B"
Article 17 Rate of Compensation
July 1st 2023 – June 30th 2024
2.00 % Increase:

The hourly rate of compensation for employees is as shown in the table below:

<i>Officer Status</i>	New Rates Effective July 1, 2023 - June 30, 2024		
	Base Rate of Pay	Eve Shift (5%)	Mid Shift (7%)
Special	21.88	22.98	23.42
Reserve 0-36 months of service	21.88	22.98	23.42
Reserve 36+ months of service	22.59	23.72	24.18

NUMBER

23-03

COMMONWEALTH OF MASSACHUSETTS
TOWN of BOXFORD

FEE

\$50.00

This is to Certify that STONE HOUSE FARM, INC.

IS HEREBY GRANTED A
COMMON VICTUALLER'S LICENSE

In said 276 Washington Street, West Boxford and at that place only and expires December thirty-first **2023** unless sooner suspended or revoked for violation of the laws of the Commonwealth respecting the licensing of common victuallers. This license is issued in conformity with the authority granted to the licensing authorities by General Laws, Chapter 140, and amendments thereto.

In Testimony Whereof, the undersigned have hereunto affixed their official signatures.

For the SELECT BOARD

Date: _____

Matthew Coogan, Town Administrator

The Commonwealth of Massachusetts

TOWN of BOXFORD

APPLICATION FOR PERMIT

No. _____ 4/25/03 _____
(Date)

TO THE LICENSING AUTHORITIES:

In accordance with the provisions of the Statutes relating thereto, application for a Permit is hereby made by

Name Stone House Farm Inc
(Full name of person, firm or corporation making application)

516 Washington Street West Boxford MA 01885
(Give location by street and number)

To operate a retail food establishment
processing chicken, Beef, Turkey, Waddles Pies
Baked Goods, Bread & Sausages

State clearly purpose for which permit is requested

(Signature of applicant)
516 Washington St
West Boxford MA 01885
(Address)

Permit issued _____

GAZEBO RENTAL AGREEMENT

The applicant named below requests to rent Boxford's Gazebo, under the following conditions;

1. Rental is made to a Town of Boxford resident over the age of 18.
2. Gazebo hours of Operation - 9AM until 1 hour after Sunset – unless later time is pre-authorized by the permitting authority.
3. Music and Lighting: Electronic or live music shall be in good taste, and it shall conform to the community's standards. The sponsor shall ensure that the volume shall be kept at a reasonable level, and the sponsor shall cause the volume to be lowered if requested by a local resident or Town official. Music and Lighting will be prohibited 1 hour after sunset or longer with a pre-authorized extension from permitting authority.
4. No alcohol on premises without valid liquor distribution permit
5. No food may be served without a valid food service permit
6. All signs must comply with Town Bylaw. Directional signage must be approved by the Selectmen's Office.
7. No admission charge. Collections or other money raising activities are allowed as permissible by law.
8. Public Restroom Facilities: The sponsor shall provide at least one handicap accessible portable restroom for an event lasting more than four hours. Any existing portable restrooms associated with the adjacent ball playing field will satisfy this requirement.
9. Renter is responsible to clean up the Gazebo after use. If you have large amounts of refuse, bag it and take it with you. Should janitorial services be required, a reasonable fee will be assessed to the user.
10. No lit candles, smoke machines, or fireworks allowed within Gazebo.
11. Use of any tape, tacks, screws, or nails for the hanging, tacking and/or posting of flyers, signs, and/or posters on the structure are prohibited.
12. The undersigned has read the attached regulations governing the use of Boxford's Gazebo and has agreed to comply with them and to assume full responsibility for any damage or loss to the Town as a result of use and/or misuse of the Gazebo by the renter or their invitees and agrees to reimburse the Town for said loss. The undersigned further assumes personal responsibility for any and all liability to any person(s) arising out of the use of the Gazebo and agrees to hold the Town of Boxford and their agents harmless from, and indemnify them against, any and all claims, demands, liability and damages resulting from the use of the Gazebo by anyone at the event held therein.

**Please return completed application to the Office of the Board of Selectmen,
7A Spofford Road, Boxford, MA 01921 at least 15 days prior to intended rental date.**

Name West Boxford Improvement Society, Application date 4/27/2023

Address P.O. Box 283, West Boxford, MA 01885

Phone 508-523-1344 Date of rental July 29, 2023 Time(s) of rental 9am - 6 pm

Type of function Boxford's 4th Annual Summer Fest - Community Concert, Coolout + games for kids Number of attendees 500 +/-

Rental fees are charged to assist with maintenance and security costs. Fees do not apply to Town uses. All fees are due and payable to the Town of Boxford no later than ten (10) days in advance of the meeting.

- Gazebo Rental (Resident) \$ 50.00
 - Security Deposit* \$100.00
- Non profits may apply for fee waiver

*Security deposits may be claimed four business days after your event, after a satisfactory inspection of the structure by Town Staff.

Copy of insurance policy provided? (yes) _____ (no)

----- DO NOT WRITE BELOW THIS LINE -----

Action taken: _____ Date: _____

Fee Amount: \$ _____ Collected? (yes) _____ (no) _____