



BOXFORD SELECT BOARD

Monday, April 24, 2023

Town Hall 7A Spofford Road

Meeting Room 1

Remote option through Zoom:

<https://us02web.zoom.us/j/8157412201?pwd=WFIUWU1PS1c2NGNuZUJ3TERNbWpRQT09>

REVISED AGENDA

This meeting is audio and video recorded

7:00 PM Call to Order

7:05 PM Announcements

7:10 PM Proclamations for Center at 10 Elm

7:20 PM Meeting with the Boxford Library Board of Trustees

- Discussion on request to place a sign in front of Town Hall
- Any other business to come before the Library Board of Trustees and the Select Board not anticipated at the time of this posting.

7:35 PM Meeting with Boxford Housing Partnership Committee

- Discussion on new Small Repair Grant Program appointees
- Any other business to come before the Housing Partnership Committee and the Select Board not anticipated at the time of this posting.

7:50 PM Discussion on May 9, 2023 Town Meeting

- Assignment of Warrant Articles at Town Meeting
- Select Board recommendations of Warrant Articles

8:05 PM Report of the Town Administrator

- Proposal for Eagle Scout Project – Bike repair stations at PD and East Fire Station
- Alcohol Sale Permit on Private Property Application, iFarm
- Consider approval of health insurance rates for FY24
- Consider approval of Memorandum of Agreement for new Boxford Communications Dispatchers Association
- Application for MassHousing Partnership MBTA Communities Technical Assistance Program

- Declaration of surplus items
- Regional Retirement request for one-time COLA adjustment
- Discussion on FY23 Performance Evaluation Process
- Any other business to come before the Town Administrator and the Board not anticipated at the time of this posting

8:25 PM Routines

- Correspondence
- Appointments
- Approval of Minutes
- School and Non-School Warrants

8:30 PM Any other business to come before the Board

Adjourn

Next Meeting – May 8, 2023

New Call to Order

I call this meeting to order and inform all that this meeting is being video and audio recorded.

Pursuant to Chapter 2 of the Acts of 2023, this meeting will be conducted via remote hybrid means, in accordance with applicable law. This means that members of the public body as well as members of the public may access this meeting via virtual means in addition to in person through the remote participation link provided on this meeting's posting on the Town's website calendar. The website calendar also lists the specific ID number required for virtual attendance via Zoom along with phone numbers to dial into the meeting.

Additionally, the public is able to: Listen to and/or view this meeting via BCATv on FIOS channel #39 or Comcast Channel #22 or through the BCATv website; OR Participate in the meeting virtually.

Members please be aware that, if at least one member attends the meeting remotely, all votes must be roll call votes.

ANNUAL TOWN MEETING AND ELECTION

Boxford's Annual Town Meeting will take place on May 9, 2023 at 7pm in the Masconomet Auditorium, 20 Endicott Road.

Residents can access the Annual Town Meeting Warrant and supporting materials for each of the articles on the Town of Boxford website at www.boxfordma.gov/TownMeeting2023

The Annual Town Election will occur on May 16 at Town Hall, 7A Spofford Road from 7am until 8pm. The last day to register to vote (if you are not already registered) is April 30.

Registration may be accomplished online by going to online to the Secretary of the State's webpage at www.sec.state.ma.us or in person at the Town Clerk's office in Town Hall.





MODERATOR'S FORUM

Tuesday, May 2, 2023

7:00 PM

Boxford Town Hall

Meeting Room #1

**Review of all warrant articles and
override questions prior to Town
Meeting on May 9.**

The Public is Invited



Candidate's
NIGHT

The League of Women Voters
is hosting Candidates Night!

Thursday, May 4, 2023

7:00 PM

Boxford Town Hall

Meeting Room #1

For a list of candidates who are running for
election, please visit our website at
www.boxfordma.gov and click on “Annual
Town Meeting and Election” in the News
and Announcements section

Boxford

Presented by the Boxford Village Garden Club
and the Boxford Recycling Committee

EARTH DAY

Help Eliminate Litter Program

Saturday 11 - 3 pm

April 29, 2023

Collect litter around town

Drop off at the

Recycling Center

behind the **Town Hall**

Receive a free

**Benson's ice cream
sundae!**

Visit our exhibitors:

- * fun crafts * beekeeping *
- * conservation tips *
- * gardening advice *
- * meet the goats and more! *



Paper Shredding

11:30 - 2:30 pm

1 box (1' x 1' x 2')

FREE per resident

****No household trash permitted**

Event will run rain or shine

Town of Boxford

Community Workshops

We want to hear from you!

We are Studio Luz Architects and we are working with the Town of Boxford and MassDevelopment to create a new vision for two surplus properties located at 4 Middleton Road and 188 Washington Street that will benefit the surrounding Boxford community. We want to hear your thoughts. What would you like to see happen at 188 Washington Street and 4 Middleton Road?

This new vision for 4 Middleton Road and 188 Washington Street will be based off community input, market analysis and the programmatic needs of the town, defining the future programming and connecting the vision to the Boxford Town Facility master plan and Town Meeting cycle.

The goal is to develop consensus for future use of 4 Middleton Street and 188 Washington Street and produce comprehensive documentation of programming scenarios to inform a subsequent Request for Proposals for the redevelopment of the property for the new proposed use.

Please join us at our in-person and virtual workshops!

05/15

In-Person

Visioning Workshop

7:00 pm-8:00 pm

10 Elm Street, Boxford, MA

05/18

Virtual

Visioning Workshop

7:00 pm-8:00 pm

Zoom Meeting

Scan here for
more information



Town of
Boxford
Massachusetts

MassDevelopment

STU
DIO
LUZ
ARCHITECTS

www.boxfordma.gov/VillageCenters

From: [Kevin Bourque](#)
To: [Matt Coogan](#)
Cc: [Brendan Sweeney](#)
Subject: Request to be on Select Board agenda
Date: Tuesday, March 28, 2023 2:35:03 PM

External Sender

Hello Matt,

The Library Trustees would like to be put on the Select Board agenda for Monday April 24th (or a meeting date thereafter). The Library Trustees would like to have the Select Board approve the placement of a sign on the grassy area in front of the Town Hall / Library building.

This is the motion approved by the Library Board of Trustees on Monday, March 13, 2023:
Advocate that the Select Board approve the placement of a sign on the grassy area in front of the Town Hall/Library building based upon the approved design. (see attached image file for reference)

MOTION: J. Smallman made a motion, seconded by C. Eckert to approve the proposal as presented to go before the Select Board for their approval.

ROLL CALL: Ryan yes, Smallman yes, Eckert yes, Pelley yes, Ramos-Pachucki yes, Woodland yes.

Let me know if you need any further information regarding this agenda item that trustees would like to bring before the Select board.

Also, Robin Phelan recommended the trustees post a joint meeting agenda for the meeting that this item will be discussed in case a quorum of trustees is present and need to conduct any deliberations. If this item will be on the April 24 meeting agenda, I will need to know before April 13 so I can post the agenda with Robin Phelan. I'm on vacation April 15-23.

Thank you,
Kevin

Kevin J. Bourque
Library Director
Boxford Town Library
978-887-7323
www.boxfordma.gov/town-library



Boxford

TOWN HALL &
TOWN LIBRARY

**BOXFORD HOUSING PARTNERSHIP
SELECT BOARD
APRIL 24, 2023**

Dear Members of the Select Board,

The Housing Partnership requests assistance from the Select Board in establishing the Board of Trustees for the Boxford Small Repair Grants Trust. The Trust received final approval from the State in January, 2023 and we are ready to proceed. In Section 3 (a), the Trust document states that the Select Board must appoint the 5 members of the trust. The entire Trust document is also attached as a reference. In anticipation of this, the Housing Partnership has voted to recommend me as their representative to the Trust.

Please let me know if the Housing Partnership can be of any assistance.

Joe Hill
Chair, Housing Partnership

BOXFORD SMALL REPAIR GRANTS TRUST

SECTION 3. (a) The board of trustees shall consist of 5 members to be appointed {BY} the select board of the town of Boxford, 1 of whom shall be a member of the select board, 1 of whom shall be from a resident of the town of Boxford, 1 of whom shall be a member of the town housing partnership committee, 1 of whom shall be a member of the Boxford council on aging and 1 of whom shall be the town administrator or their designee. All members of the board shall serve for 2-year overlapping terms, except the town administrator or their designee.

Initially, appointments to the board of trustees shall be staggered terms, with 2 members serving for 1-year terms and 2 members serving for 2-year terms. The members of the board shall serve without compensation but shall be reimbursed by the trust for expenses incurred in the performance of the member's duties.

Acts (2022)

Chapter 443

AUTHORIZING THE TOWN OF BOXFORD TO ESTABLISH THE BOXFORD SMALL REPAIR GRANTS TRUST

Be it enacted by the Senate and House of Representatives in General Court assembled, and by the authority of the same, as follows:

SECTION 1. There shall be a municipal trust known as the Boxford Small Repair Grants Trust, herein referred to as the “trust”, to advance the public purpose of ensuring the maintenance of safe and sanitary housing for income-qualified residents of the town of Boxford who are 60 years of age or older or who have a permanent disability.

SECTION 2. The purpose of the trust shall be to provide funds for the preservation of housing in the town of Boxford for the benefit of income-qualified Boxford residents through the Boxford Small Repair Grant Program, which shall provide financial assistance for the benefit of low- and moderate-income households in order to preserve existing housing units for health and safety purposes. The purpose of the grant program will be to enable income-qualified residents to continue to age in place and in their community through essential modifications to their homes, which shall serve the public interest and address a

community need.

The trust shall be governed by a board of trustees in accordance with the authority granted by town meeting and shall dispense funds as grants as the board shall deem appropriate to carry out the purposes of the trust consistent with the policies adopted from time to time by the board.

SECTION 3. (a) The board of trustees shall consist of 5 members to be appointed the select board of the town of Boxford, 1 of whom shall be a member of the select board, 1 of whom shall be from a resident of the town of Boxford, 1 of whom shall be a member of the town housing partnership committee, 1 of whom shall be a member of the Boxford council on aging and 1 of whom shall be the town administrator or their designee. All members of the board shall serve for 2-year overlapping terms, except the town administrator or their designee.

Initially, appointments to the board of trustees shall be staggered terms, with 2 members serving for 1-year terms and 2 members serving for 2-year terms. The members of the board shall serve without compensation but shall be reimbursed by the trust for expenses incurred in the performance of the member's duties.

(b) Members of the board shall be sworn to the faithful performance of their official duties. A majority of the members shall constitute a quorum for the transaction of any business. The board shall elect from among its members a chair, vice-chair, clerk and other officers as it finds necessary and determine their duties.

(c) The original members of the board shall be appointed within 60 days following the effective date of this act. In the event of a vacancy on the board, a successor member shall be appointed by the

select board to complete the unexpired term.

(d) Any member of the board of trustees may be removed by the select board.

(e) The board of trustees shall meet not less than twice a year and more often as determined necessary by the board.

(f) The board of trustees are hereby authorized to execute a declaration of trust governing the trust.

SECTION 4. (a) There shall be a trust fund to be known as the Boxford Small Repair Grants Trust Fund. The fund shall be separate and apart from the General Fund of the town of Boxford.

(b) The town treasurer shall be the custodian of the trust fund consistent with section 46 of chapter 41 of the General Laws.

(c) The trust fund shall receive and hold all gifts and grants made to the trust fund as well as money appropriated by the town to the trust.

(d) Money in the trust fund shall be available for expenditure by the trust for the purposes set forth in this act, and subject to any restrictions contained in any gift or grant, without the need for further appropriation by town meeting.

SECTION 5. (a) The trust, by and through its board of trustees, may:

(i) disburse funds consistent with the requirements of this trust; provided, however, that the maximum amount that can be granted to any 1 applicant or residence is \$7,500;

(ii) establish the grant program parameters such as the guidelines, limits, eligibility and residency requirements, eligible uses of funds and any other parameters that the trust deems necessary to ensure the objectives of the trust;

(iii) accept and receive money by gift, grant, contribution, bequest or transfer from any person, firm, corporation or other public or private entity or any other source; provided, however, that a record of any restrictions on any contribution to the trust shall be maintained;

(iv) execute, acknowledge and deliver contracts, grant agreements and other instruments sealed or unsealed, necessary, proper or incident to a transaction in which the board engages for the accomplishment of the purposes of the trust; and

(v) issue policy goals and statements to serve as guidelines for the trust.

(b) General revenues appropriated into the trust become trust property and may be expended without further appropriation. All money remaining in the trust at the end of a fiscal year, whether or not expended by the board within 1 year of the date the money was appropriated into the trust, shall remain trust property.

(c) The trust is a public employer, and the members of the board are public employees for the purposes of chapter 258 of the General Laws.

(d) The trust shall be deemed a municipal agency and the trustees special municipal employees for the purposes of the General Laws, including, but not limited to, chapter 268A of the General Laws.

(e) The trust is exempt from chapters 59 and 62 of the General Laws and from any other general law concerning payments of taxes based upon or measured by property or income imposed by the commonwealth or a political subdivision of the commonwealth.

(f) The books and records of the trust shall be audited annually by an independent auditor in accordance with generally accepted

accounting practices.

(g) The trust is a public body for the purposes of sections 18 to 25, inclusive, of chapter 30A of the General Laws.

(h) The trust is a board of the town for the purposes of chapters 30B and section 15A of chapter 40 of the General Laws; provided, however, that agreements and conveyances between the trust and agencies, boards, commissions, authorities, departments and public instrumentalities of the town shall be exempt from said chapter 30B.

(i) The trust may act and do things necessary or convenient to carry out the purposes expressly granted in this act.

(j) The board of trustees shall be considered a town board subject to the by-laws of the town except as may be otherwise expressly provided in this act.

SECTION 6. The financial records of the trust shall be subject to control and oversight by the town except as may be otherwise expressly provided in this act.

SECTION 7. (a) The trust shall provide grants to residents of the town Boxford whose income is not greater than 100 per cent of the area median income, as defined by the department of housing and community development, and who are: (i) 60 years of age or older; provided, however, that if the applicant is a couple, at least 1 of the applicants shall be 60 years of age or older; or (ii) of any age with a permanent disability; provided, however, that for the purposes of this section, "permanent disability" shall mean incapacity that will continue for an indefinite period which is likely never to end, even though recovery at some remote or unknown time is possible.

To be eligible, the resident must be the record owner of the house or, if the house is in a trust, the resident must be a beneficiary of

the trust and must give written authority to make the requested repairs to the residence.

(b) Any application submitted for grant funds shall be confidential, except to the extent required to be disclosed pursuant to section 10 of chapter 66 of the General Laws.

(c) The recipient of a grant shall execute a grant agreement in favor of the trust, which shall set forth the purpose for which the grant is awarded and the terms and conditions associated with the grant, including a requirement that in the event all or a portion of the funds are not used for the purposes consistent with this act, such funds shall be returned to the trust.

SECTION 8. If the trust is terminated, the remaining funds in the trust shall be returned to the town of Boxford and held by the select board for affordable housing purposes.

SECTION 9. This act, being necessary for the welfare of the commonwealth and the town of Boxford and its inhabitants, shall be liberally construed to affect its purposes.

SECTION 10. This act shall take effect upon its passage.

Approved, January 5, 2023.

#	Warrant Article
1	Receive Annual Reports
2	Fund First Year of Negotiated Collective Bargaining Agreements
3	Adopt Personnel Board Classification Plan and Compensation Plan
4	Adopt FY 2024 Budget - \$39,343,454
5	Supplement Funding for Fire Department Medical Response Program FY24 - \$75,000
6	Override: Elementary Schools FY2024 Budget - \$265,216
7	Override: Masconomet Regional School District Assessment FY2024 - \$266,316
8	Fund prior year bills FY2022 - \$3,409.38
9	Establish Opioid Settlement Stabilization Fund
10	Set annual curbside solid waste collection fee
11	Fund Omnibus Capital Budget - \$828,200
12	Fund Security Camera Systems at Elementary Schools - \$300,000
13	Fund Masco Turf Fields, Stadium and Structures Engineering Design - \$167,451
14	Debt: New Fire Engine 6 - \$550,000
15	CPC: Annual Budget and Reserves - \$1,298,786
16	CPC: Purchase of Dorman Property, 0 Herrick Road - \$1,500,000
17	CPC: Johnson Playground Engineering and Design - \$25,000
18	CPC: Mt. Vernon Cemetary New Wall - \$3,000
19	Rail Trail Right of Way Easement Acquisition
20	Permanent Easement -791 Main Street Fire Hydrant
21	ByLaw - Increase Number of Council on Aging Members to 9
22	ByLaw - Masconomet Regional Agreement Amendment 19
23	Any other business

TOWN OF BOXFORD

Website: BoxfordMA.gov

**Warrant for Annual Town Meeting
Tuesday, May 9, 2023
7:00 p.m.**

**Masconomet Regional High School
20 Endicott Road
Boxford, MA 01921**



Supporting documents for this warrant may be found at:

<https://www.boxfordma.gov/TownMeeting2023>

WARRANT FOR ANNUAL TOWN MEETING
May 9, 2023 - 7:00 P.M.

MASCONOMET REGIONAL HIGH SCHOOL – AUDITORIUM

Commonwealth of Massachusetts
Essex s.s.

To either of the Constables of the Town of Boxford in said County,

GREETINGS:

In the name of the Commonwealth of Massachusetts, you are hereby directed to notify and warn the inhabitants of the Town of Boxford qualified to vote in elections and in Town affairs to meet at the **Masconomet Regional High School**, 20 Endicott Road, Boxford, on **Tuesday the ninth day of May next at 7:00 P.M.**, then and there to act on the following articles, viz:

ARTICLE 1. To receive and place on file the reports of the Town Officers and Committees without ratification of any action taken or authorization of any action proposed; or take any other action thereon.

Sponsored and Supported by the Select Board

ARTICLE 2. To see if the Town, in accordance with M.G.L. Chapter 150E, section 7, **will vote to appropriate a sum of money to fund the first-year cost items contained in the following collective bargaining agreements** recently negotiated and ratified by the Select Board between the Town and the following Unions which have terms of July 1, 2023 through June 30, 2026:

- **American Federation of State, County and Municipal Employees, AFL-CIO Council #93, Local 939, Clerical/ Library**
- **International Association of Fire Fighters, AFL-CIO Local 5305, Boxford Professional Fire Fighters**
- **International Brotherhood of Teamsters Local 25, Boxford Police Patrol Officers**
- **Boxford Communications Dispatchers and Police Secretarial Employees Association**
- **Boxford Police Reserve Association**

Said collective bargaining agreements are on file with the Town Clerk; funding for the cost items in the first year of said agreements is included in the general operating budgets of the Town; or take any other action thereon.

Sponsored by Select Board
Select Board to make recommendation at Town Meeting
Finance Committee to make recommendation at Town Meeting

ARTICLE 3. To see if the Town will vote to adopt the Classification Plan and Compensation Plan for FY 2024, as submitted by the Personnel Board under Chapter 23 of the Town Code; said Classification Plan and Compensation Plan as printed on pages 15 through 17 of this warrant; funding for estimated costs of said plan included in the general operating budget of Town in Article 4; or take any other action thereon.

Sponsored and Supported by the Personnel Board
Select Board recommends adoption of this article
Finance Committee to make recommendation at Town Meeting

ARTICLE 4. To **act on the proposed budget** and see what sums of money the Town will vote to raise and appropriate, or transfer from available funds, for the use of several departments for Fiscal Year 2024, to wit: General Government, Financial Administration, Public Safety, Education, Public Works, Health & Human Services, Culture & Recreation, Employee Benefits, Debt Service, and all other necessary proper expenses during said fiscal year; and authorize expenditure of these funds under the direction of the appropriate listed department; or take any other action thereon.

Sponsored and Supported by the Finance Committee
Estimate: \$39,343,454
Select Board recommends adoption of this article
The proposed budget is printed on pages 13 and 14 of this warrant.

ARTICLE 5. To see if the Town will vote **to raise and appropriate \$75,000** for the Medical Response Pilot Program in the Fiscal Year 2024 Fire Department budget; or take any other action thereon.

Sponsored and supported by the Select Board
Finance Committee recommends adoption of this article

NOTE: At this time, we anticipate that **Article 6 and Article 7** will each be offered as a "contingent appropriation." This means that although the appropriation could be approved at the Annual Town Meeting, that appropriation would be fully contingent upon successful passage of the related Proposition 2½ ballot questions. Should the override question fail, the appropriation would be rendered null and void. In the case of Article 7, the Masconomet Regional School District budget would be rejected (the district budget must be accepted by at least two of the three member communities).

ARTICLE 6. To see if the Town will vote **to raise and appropriate or transfer from available funds the sum of \$265,216** for the purpose of additionally funding the Fiscal Year 2024 Elementary School Budget; provided, however, that the appropriation authorized herein shall be subject to and contingent upon approval of the voters at the Town Election to assess additional real estate and personal property taxes in accordance with the provisions of Proposition 2 1/2, so called; or take any other action thereon.

Sponsored and supported by the Elementary School Committee
Finance Committee recommends adoption of this article
Select Board recommends adoption of this article

ARTICLE 7. To see if the Town will vote **to raise and appropriate or transfer from available funds the sum of \$266,316** for the purposes of additionally funding the Fiscal Year 2024 Masconomet Regional School District Assessment, thereby meeting the Town’s total District assessment, provided, however, that the appropriation authorized herein shall be subject to and contingent upon approval of the voters at the Town Election to assess additional real estate and personal property taxes in accordance with the provisions of Proposition 2 ½, so called; or take any other action thereon.

Sponsored and supported by the Masconomet Regional District School Committee
Finance Committee recommends adoption of this article
Select Board recommends adoption of this article

ARTICLE 8. To see if the Town will vote to **transfer and appropriate from Free Cash the sum of \$3,409.48** to be expended by the Town to fund bills from FY2022 for snow and ice treatment; or take any other action thereon.

--4/5ths vote

Sponsored and supported by the Select Board
Finance Committee recommends adoption of this article

ARTICLE 9. To see if the Town will vote, pursuant to the provisions of G.L. c.40, §5B, **to create a new special purpose stabilization fund, to be known as the Opioid Settlement Stabilization Fund**, which may be expended for all of the purposes allowed by law, including those outlined in applicable opioid-litigation settlement documents, a document prepared by the Substance Abuse Bureau of the Commonwealth’s Office of Health and Human Services Department, found at www.mass.gov/doc/massachusetts-abatement-terms/download entitled “Abatement Strategies”, and consistent with any state guidelines or regulations further clarifying allowable uses of opioid litigation settlement funds; and further, to adopt the last paragraph of said §5B and dedicate to such fund, without further appropriation, 100% of the opioid litigation settlement funds received by the Town; and further, to transfer from Free Cash a sum of money equal to that received by the Town from opioid litigation settlements resulting from the Town’s participation in the national Opioid Multi-District Litigation into said Opioid Settlement Stabilization Fund; or take any other action related thereto.

Sponsored and supported by the Finance Committee
Select Board recommends adoption of this article

ARTICLE 10. To see if the Town will vote to set the following **annual curbside solid waste collection fees: \$6.00 for each 32-gallon overflow bag; \$52 for an additional 64-gallon trash barrel; \$120 per year collection fee per additional 64-gallon barrel;** or take any other action thereon.

Sponsored and Supported by the Board of Health
Finance Committee recommends adoption of this article
Select Board recommends adoption of this article

ARTICLE 11. To **act on the list of proposed equipment and capital purchases** for FY 2024 and see what sums of money the Town will vote to transfer from Free Cash, for the use of several departments for fiscal year 2024, and authorize expenditure of these funds for such purposes under the direction of the appropriate listed department and authorize the Select Board or School Committees to dispose of any equipment declared surplus if replaced; or take any other action thereon.

Sponsored and supported by the Select Board
Estimate: **\$828,200**
Finance Committee recommends adoption of this article
Permanent Building Committee recommendations as noted
Sustainability Committee recommendation as noted
The proposed FY24 capital budget is printed on page 18 of this warrant.

ARTICLE 12. To see if the Town will vote to **transfer and appropriate from Free Cash a sum of money** to be expended under the direction of the Permanent Building Committee, with the advice of the School Administration, to install security camera systems at Harry Lee Cole Elementary School (\$150,000) and Spofford Pond Elementary School (\$150,000), for a total expenditure of \$300,000, including all incidental and related expenses, or take any other action thereon.

Sponsored by the Select Board
Boxford School Committee recommends adoption of this article
Select Board to make recommendation at Town Meeting
Finance Committee to make recommendation at Town Meeting
Permanent Building Committee to make recommendation at Town Meeting

ARTICLE 13. To see if the Town will vote to **transfer and appropriate from Free Cash the sum of \$167,451** to be expended by the Masconomet Regional School District Committee, with the advice of the School Superintendent, to design and permit artificial turf athletic fields, stadium, restrooms, locker rooms, press box, and concession stand, including all incidental and related expenses, or take any other action thereon.

Sponsored and supported by the Masconomet Regional District School Committee
Finance Committee does not recommend adoption of this article
Select Board does not recommend adoption of this article

ARTICLE 14. To see if the Town will vote to appropriate **\$550,000.00** to be expended, under the direction of the Select Board, to purchase and equip a replacement fire truck mini pumper tanker vehicle (to be known as Engine 6), including the payment of all costs incidental or related thereto (the "Project"); and to meet this appropriation, authorize the Treasurer with the approval of the Select Board to borrow said amount under and pursuant to Massachusetts General Laws Chapter 44, Section 7, or pursuant to any other enabling authority, and to issue bonds or notes of the Town therefor; and to authorize the Chief Procurement Officer and the Select Board to enter into any and all agreements and execute any and all instruments as may be necessary on behalf of the Town to effectuate the execution of said Project; provided further that the amount

of borrowing authorized pursuant to this vote shall be reduced by any grant amount received prior to the issuance of any bonds or notes under the authority of this vote; or take any other action thereon.

Sponsored and supported by Select Board
Finance Committee recommends adoption of this article

ARTICLE 15. To see if the Town will vote to **appropriate or reserve from the Community Preservation Fund annual revenues** in the amounts recommended by the Community Preservation Committee for committee administrative expenses, debt service, community preservation projects and other expenses in Fiscal Year 2024, with each item to be considered a separate appropriation:

Appropriations:

From FY 2024 estimated annual revenues for Lincoln Hall Renovation Bond expense	\$40,775
From FY 2024 estimated annual revenues for Haynes Land Purchase Bond expense	\$116,500
From FY 2024 estimated annual revenues for Aaron Wood Renovation Bond expense	\$14,151
From FY 2024 estimated annual revenues for Boxford Commons Bond expense	\$133,500
From FY 2024 estimated annual revenues for 10 Elm Street Bond expense	\$75,000
From FY 2024 estimated annual revenues for Committee Administrative expenses	\$66,469

Reserves:

From FY 2024 estimated annual revenues for Community Housing Reserve	\$132,939
From FY 2024 estimated annual revenues for Historic Reserve	\$3,013
From FY 2024 estimated annual revenues for Open Space Reserve	\$16,439
From FY 2024 estimated annual revenues for Budgeted Reserve	\$700,000

or take any other action thereon.

Sponsored and supported by the Community Preservation Committee
Select Board recommends adoption of this article
Finance Committee to make recommendation at Town Meeting

ARTICLE 16. To see if the Town will vote to authorize the Select Board to acquire by purchase, gift, eminent domain, or otherwise all or a portion of **a 35+ acre parcel of land on Herrick Road, Boxford, also known as the Dorman Property**, shown on a plan of land entitled “Compiled Plan in Boxford, MA Prepared for Town of Boxford,” drawn by Donohoe Survey, Inc., dated January 25, 2023, on file with the Town Clerk; that said land be conveyed to the Town of Boxford under the provisions of Massachusetts General Laws, Chapter 44B, as it may hereafter be amended, and to be under the care, custody, management and control of the Select Board and held for the following purposes authorized under the Community Preservation Act:

- a) Acquisition, creation, preservation, rehabilitation and restoration of open space, and
- b) Acquisition, creation, preservation, rehabilitation and restoration of land for recreational use;

and that to fund said purchase including all costs incidental and related thereto including closing costs, legal expenses and feasibility studies and associated plans, to appropriate the sum of 1,500,000 or any

other amount; and that to meet this appropriation, the sum of \$1,500,000 be transferred from the Undesignated Community Preservation Fund balance; and to authorize the Select Board to grant conservation restrictions or other such perpetual restrictions as may be permitted pursuant to the Community Preservation Act, on all or any portion of said parcel; and, further, to authorize the Select Board to apply for and accept grants, donations or reimbursements for this purpose in any way connected with the scope of this article, and to enter into all agreements and execute any and all instruments as may be necessary on behalf of the Town to effect said purchase, or take any other action thereon.

Sponsored and supported by the Community Preservation Committee
Land Committee recommends adoption of this article
Select Board recommends adoption of this article
Finance Committee to make recommendation at Town Meeting

ARTICLE 17. To see if the Town will vote to appropriate **\$25,000 from the Undesignated Community Preservation Fund balance to fund the preparation of engineering plans, wetland delineation, survey plan, concept designs, preliminary project plan and any other permitting costs** for construction of a new playground to replace the existing playground at Johnson Field located at 7A Spofford Road; said funds to be expended under the direction of the Permanent Building Committee, or take any other action thereon.

Sponsored and supported by the Community Preservation Committee
Finance Committee recommends adoption of this article
Permanent Building Committee recommends adoption of this article
Recreation Committee recommends adoption of this article
Select Board recommends adoption of this article

ARTICLE 18. To see if the Town will vote to appropriate **\$3,000 from the Community Preservation Historic Fund balance to help fund the demolition of an existing retaining wall and the construction of a new retaining wall** at the Mt. Vernon Cemetery located on Main Street and identified as Assessor's map 12, block 1, lot 14, including any related costs and expenses; with matching funds provided by the Mt. Vernon – Brookside Cemetery Corp for a total project costs of \$5,973, said funds to be expended under the direction of the Community Preservation Committee, or take any other action thereon.

Sponsored and supported by the Community Preservation Committee
Finance Committee recommends adoption of this article
Select Board recommends adoption of this article

ARTICLE 19. To see if the Town will vote to (a) authorize the Select Board to acquire, by purchase and/or gift, the fee to and/or permanent and/or temporary easements, for public way purposes, including without limitation, for the construction, installation, maintenance, improvement, repair, replacement

and/or relocation of a shared path and rights of way, slopes, grading, construction, landscaping, and other appurtenances and/or facilities, to enable the Town to undertake the Boxford/Georgetown Border to Boston Project and for any and all purposes incidental or related thereto, in, on and under certain parcels of land approximately shown on plans entitled “Massachusetts Department of Transportation Highway Division Plan and Profile of Border to Boston Trail in the Towns of Boxford & Georgetown Essex County,” prepared by Stantec, on file with the Town Clerk, as said plans may be amended and/or incorporated into an easement plan, and land within 200 feet of said parcels; (b) transfer the care, custody, and control of a portion or portions of the Town-owned property or properties shown on the aforesaid plans from the board or officer having custody of the same for the purposes for which such properties are currently held to the Select Board for shared path and public way purposes and further to dedicate said portions of the Town-owned properties to the foregoing purposes, and, if applicable, authorize the Select Board to submit petitions to the General Court to allow the foregoing under Article 97 of the Massachusetts Constitution or otherwise; (c) authorize the Select Board to enter into all agreements and take any and all actions as may be necessary or appropriate to effectuate the foregoing purposes; or take any other action thereon.

Sponsored and supported by the Select Board
Border to Boston Trail Committee recommends adoption of this article

ARTICLE 20. To see if the Town will vote to authorize the Select Board to acquire, by gift, or otherwise, a permanent easement for the purpose of access to and the right to operate, maintain, repair and replace a fire hydrant located at property known as 791 Main Street, Boxford; and, further, to authorize the Select Board to enter into all agreements and execute any and all instruments as may be necessary on behalf of the Town to carry out the purposes of this article, or take any other action thereon.

Sponsored and supported by the Select Board

ARTICLE 21. To see if the Town will vote to amend Chapter 7, Section 7-15 the of Town’s general bylaw by striking the language as indicated below and by inserting the ***bold, italicized text:***

A Council on Aging of ~~seven~~***nine*** members shall be appointed by the Select Board for four-year overlapping terms of office. The terms of no more than three members shall expire in any calendar year. Members shall be eligible for reappointment for concurrent terms.

Sponsored and supported by the Select Board
Council on Aging recommends adoption of this article

ARTICLE 22. To see if the Town will vote to amend subsection D of Section IV (“Apportionment of Capital Costs”) of the Masconomet Regional School District Agreement, as recommended by the Masconomet Regional School District School Committee, by striking the language as indicated below and by inserting the ***bold, italicized text***:

D. Apportionment of Capital Costs

1. All capital costs of the regional school district for ~~each fiscal year~~ ***Fiscal Year 2024*** shall be apportioned ~~annually~~ to the member towns on the basis of their respective pupil enrollments on October 1 of the preceding year in grades 7 through 12 residing in each member town and receiving education at such town’s expense, except that pupils for whom a member town is paying tuition for ***non-resident vocational programs or*** special education as provided under Chapters 74 and 71B of the General Laws, and pupils attending the Essex North Shore Agricultural and Technical School shall be excluded from the pupil enrollments for this purpose. Each member town’s share for ~~each fiscal year~~ ***Fiscal Year 2024*** shall be determined by computing the ratio which that town’s pupil enrollment as specified above bears to the total of such pupil enrollments in all the member towns of the regional school district on that same date. Debt service included in capital costs shall be apportioned as a capital cost of the year in which the same falls due.

2. ***All capital costs of the regional school district for Fiscal Year 2025 shall be apportioned to the member towns on the basis of their respective pupil enrollments on October 1 of the preceding four (4) years in grades 7 through 12 residing in each member town and receiving education at such town’s expense, except that pupils for whom a member town is paying tuition for non-resident vocational programs or special education as provided under Chapters 74 and 71B of the General Laws, and pupils attending the Essex North Shore Agricultural and Technical School shall be excluded from the pupil enrollments for this purpose. Each member town’s share for Fiscal Year 2025 shall be determined by computing the ratio which that town’s pupil enrollment as specified above bears to the total of such pupil enrollments in all the member towns of the regional school district on October 1 of the preceding four (4) years. Debt service included in capital costs shall be apportioned as a capital cost of the year in which the same falls due.***

3. ***All capital costs of the regional school district for Fiscal Year 2026 and thereafter shall be apportioned to the member towns on the basis of their respective pupil enrollments on October 1 of the preceding five (5) years in grades 7 through 12 residing in each member town and receiving education at such town’s expense, except that pupils for whom a member town is paying tuition for non-resident vocational programs or special education as provided under Chapters 74 and 71B of the General Laws, and pupils attending the Essex North Shore Agricultural and Technical School shall be excluded from the pupil enrollments for this purpose. Each member town’s share for Fiscal Year 2026 and thereafter shall be determined by computing the ratio which that town’s pupil enrollment as specified above bears to the total of such pupil enrollments in all the member towns of the regional school district on October 1 of the preceding five (5) years. Debt service included in capital costs shall be apportioned as a capital cost of the year in which the same falls due.***

Or take any other action thereon.

Sponsored and supported by the Masconomet Regional School District School Committee.
Select Board recommends adoption of this article.

Finance Committee recommends adoption of this article.

ARTICLE 23. To transact any other business that may legally come before said meeting.

Supporting documents for this warrant may be found at:
www.boxfordma.gov/TownMeeting2023

You are hereby ordered to notify and warn voters to meet in the Boxford Town Hall, 7A Spofford Road, Boxford, MA, on Tuesday, the 16th of May next, polls open from 7:00 a.m. to 8:00 p.m., for the following purposes, viz: to choose by ballot the following Town Officers for the ensuing year: **Select Board**, ONE member for three years; **Board of Assessors**, ONE member for three years; **Board of Health**, TWO members for three years; **Boxford School Committee**, TWO members for three years; **Masconomet Regional District School Committee**, TWO members for three years; **Board of Library Trustees**, TWO members for three years; **Town Moderator**, ONE for 3 years; **Constable, East Parish**, ONE for three years; **Constable, West Parish**, ONE for three years; **Board of Commissioners of Trust Funds**, ONE member for three years.

QUESTION #1: Shall the Town of Boxford be allowed to assess an additional \$265,216 in real estate and personal property taxes for the purposes of funding the Fiscal Year 2024 Elementary School Budget beginning July first?

Yes ___

No ___

QUESTION #2: Shall the Town of Boxford be allowed to assess an additional \$266,316 in real estate and personal property taxes for the purposes of funding the Fiscal Year 2024 Masconomet Regional School District Assessment beginning July first?

Yes ___

No ___

And you are directed to serve this warrant by posting attested copies thereof at each of the public meeting houses in said Town seven days, at least, before the time of holding said meeting.

Hereof, fail not and make due return of this warrant with your doing thereon to the Town Clerk at the time and place of holding said meeting.

Given under our hands this 10TH day of APRIL in the year of our Lord, two thousand twenty-two.

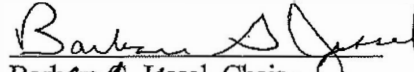
Barbara G. Jessel, Chair

Charles J. Costello, Clerk



Margaret Chow-Menzer

Peter C. Perkins

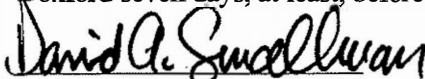

Judith A. Stickney

SELECT BOARD

I have served this warrant by posting attested copies thereof on each of the meeting houses in said Town of Boxford seven days, at least, before the time of holding said meeting.

David A. Smallman, Constable
West Parish

Date 4-19-2023

John A. Rowen, Constable
East Parish

Date 4/20/2023

Proposed Operating Budget Fiscal Year 2024

	Actual Expended FY22	Approved Budget FY23	Draft Budget FY24	\$ Change FY23 to FY24	% Change FY23 to FY24
General Government					
Select Board & Administrator	306,794	329,663	351,284	21,621	6.56%
Legal	82,447	98,361	88,361	-10,000	-10.17%
Technology	220,421	226,576	264,616	38,040	16.79%
Town Clerk	124,275	131,213	140,748	9,535	7.27%
Land Committee	0	500	500	0	0.00%
Land Use	91,238	93,958	104,874	10,916	11.62%
Utilities & General Maintenance	361,897	332,007	356,041	24,034	7.24%
Other Insurance	395,144	421,780	432,325	10,545	2.50%
Total General Government	1,582,217	1,634,058	1,738,748	104,690	6.41%
Financial Administration					
Finance Committee	179	1,010	1,010	0	0.00%
Finance Committee Reserve	175,000	175,000	175,000	0	0.00%
Municipal Finance Departments	495,884	541,556	515,392	-26,165	-4.83%
Total Financial Administration	671,063	717,566	691,402	-26,165	-3.65%
Public Safety					
Police Salary	1,282,172	1,379,937	1,443,348	63,411	4.60%
Police Non-Salary Expenses	84,208	104,020	111,045	7,025	6.75%
Fire Salary	654,579	688,530	711,760	23,230	3.37%
Fire Non-Salary Expenses	96,239	107,009	112,063	5,054	4.72%
Building Inspection/Zoning Bd	164,743	169,821	178,159	8,338	4.91%
Sealer of Weights & Measures	425	431	431	0	0.00%
Animal Inspector	5,335	5,830	0	-5,830	-100.00%
Animal Control Officer	32,633	45,722	60,000	14,278	31.23%
Communications Salary	477,540	445,374	459,793	14,419	3.24%
Communications Non-Salary Exp.	80,694	108,511	110,538	2,027	1.87%
Total Public Safety	2,878,569	3,055,185	3,187,137	131,952	4.32%
Education					
Elementary Schools*	13,122,122	13,505,697	14,136,413	630,716	4.67%
Essex NS Agricultural/Technical School	402,602	407,347	380,512	-26,835	-6.59%
Masconomet Operational Assessment*	10,773,426	11,131,422	11,651,259	519,837	4.67%
Total Education	24,298,150	25,044,466	26,168,184	1,123,718	4.49%

*Does not include operational override amounts

Public Works

Cemeteries	142	500	500	0	0.00%
Trash/Recycling Pickup & Disposal	691,800	737,382	778,984	41,602	5.64%
Snow & Ice Removal	403,000	133,000	133,000	0	0.00%
Fuel Depot	93,730	75,000	75,000	0	0.00%
DPW Salaries	648,533	678,357	716,124	37,767	5.57%
DPW Non-Salary Expense	395,976	433,364	439,842	6,478	1.49%
Total Public Works	2,233,180	2,057,603	2,143,450	85,847	4.17%

Human Services

Board of Health	160,929	179,817	183,329	3,512	1.95%
Council on Aging	141,763	171,910	182,932	11,022	6.41%
Veterans' Benefits	40,703	45,000	48,564	3,564	7.92%
HAWC Program	2,000	2,000	2,000	0	0.00%
Tri Town Council	31,095	31,095	31,095	0	0.00%
Total Human Services	376,490	429,822	447,921	18,099	4.21%

Culture & Recreation

Library Salaries	356,431	374,952	385,088	10,136	2.70%
Library Non-Salary Expense	126,557	134,184	135,544	1,360	1.01%
Celebrations/Events	4,425	4,425	4,425	0	0.00%
Cultural Council	3,000	3,000	3,000	0	0.00%
Historic District Commission	0	375	375	0	0.00%
Total Culture & Recreation	490,412	516,936	528,432	11,496	2.22%

Employee Benefits

Health Insurance (non-school)	657,629	815,913	884,123	68,210	8.36%
OPEB Contribution	300,000	300,000	250,000	-50,000	-16.67%
Essex Retirement Assessment	1,523,087	1,551,592	1,742,530	190,938	12.31%
Medicare/Life Ins (Town/School)	202,146	209,503	217,288	7,785	3.72%
Unemployment Insurance	13,371	15,000	15,000	0	0.00%
Salary Reserve	0	110,000	150,000	40,000	36.36%
Total Employee Benefits	2,696,233	3,002,008	3,258,942	256,934	8.56%

Debt Service

Permanent Debt Service	875,702	1,340,118	1,179,239	-160,879	-12.00%
Masconomet Debt Assessment	105,545	0	0	0	0.00%
Total Debt Service	981,247	1,340,118	1,179,239	-160,879	-12.00%

Total Budget	36,207,561	37,797,762	39,343,454	1,545,692	4.09%
---------------------	-------------------	-------------------	-------------------	------------------	--------------

**TOWN OF BOXFORD - COMPENSATION PLAN for
NON-BENEFIT ELIGIBLE CLASSIFICATION PLAN EMPLOYEES
FISCAL YEAR 2024**

<u>HOURLY EMPLOYEES CLASSIFICATION</u>	<u>HOURLY RATE FY2024</u>
1. Library Personnel	
Circulation Attendant	\$15.00
Library Assistant	\$17.28
2. Minutes Secretary	\$18.17 - \$22.09
3. Clerical Associate	\$17.75
4. Assistant Town Clerk	\$28.67
5. Alternate Building Inspector	\$29.03
6. Recycle Attendant	\$17.92
7. Election Officers	
Wardens	\$15.00
Inspectors	\$15.50
8. Plumbing/Gas Inspector	\$374.29 (weekly)
9. Wiring Inspector	\$374.29 (weekly)
10. DPW Summer Help	
Starting	\$17.00
Returning 2nd Year	\$17.35
Each Successive Returning Year	+ \$.35/ hour
11. Parks Program (Seasonal)	
Director	\$34.68 - \$40.80
Assistant Director	\$19.89 - \$25.00
Nurse	\$26.00 - \$37.00
Senior Counselor	\$15.50
Junior Counselor	\$15.00
12. Outreach Worker	\$18.83
13. Van Driver	\$15.83

TOWN OF BOXFORD, MA - NON-UNION CLASSIFICATION PLAN

Grade N-1

No position assigned.

Grade N-2

No position assigned.

Grade N-3

No position assigned.

Grade N-4

Animal Control Officer

Grade N-5

Administrative Services Manager/ HR Coordinator

Grade N-6

No position assigned.

Grade N-7

Assistant Treasurer/Collector of Taxes

Grade N-8

No position assigned.

Grade N-9

Director of Communications
Director of Senior Services
Town Clerk

Grade N-10

Director of Public Health
Director of Public Libraries
Inspector of Buildings

Grade N-11

Director of Assessments
Director of Land Use
Assistant Town Administrator
Treasurer/Collector

Grade N-12

No position assigned.

Grade N-13

DPW Superintendent/Town Engineer
Fire Chief

Grade N-14

Police Chief
Director of Municipal Finance/Town Accountant

Grade N-15

Town Administrator

TOWN OF BOXFORD – PROPOSED NON-UNION COMPENSATION PLAN FY 2024

<i>Grade</i>		<i>Min</i>	<i>Mid</i>	<i>Max</i>
1	Hourly	\$ 19.78	\$ 23.74	\$ 27.70
	Weekly	\$ 791.38	\$ 949.66	\$ 1,107.93
	Annual	\$ 41,310.00	\$ 49,572.00	\$ 57,834.00
2	Hourly	\$ 21.47	\$ 25.76	\$ 30.05
	Weekly	\$ 858.65	\$ 1,030.38	\$ 1,202.11
	Annual	\$ 44,821.35	\$ 53,785.62	\$ 62,749.89
3	Hourly	\$ 23.29	\$ 27.95	\$ 32.61
	Weekly	\$ 931.63	\$ 1,117.96	\$ 1,304.28
	Annual	\$ 48,631.16	\$ 58,357.40	\$ 68,083.63
4	Hourly	\$ 25.27	\$ 30.32	\$ 35.38
	Weekly	\$ 1,010.82	\$ 1,212.98	\$ 1,415.15
	Annual	\$ 52,764.81	\$ 63,317.78	\$ 73,870.74
5	Hourly	\$ 27.42	\$ 32.90	\$ 38.39
	Weekly	\$ 1,096.74	\$ 1,316.09	\$ 1,535.44
	Annual	\$ 57,249.82	\$ 68,699.79	\$ 80,149.75
6	Hourly	\$ 29.75	\$ 35.70	\$ 41.65
	Weekly	\$ 1,189.96	\$ 1,427.96	\$ 1,665.95
	Annual	\$ 62,116.06	\$ 74,539.27	\$ 86,962.48
7	Hourly	\$ 32.28	\$ 38.73	\$ 45.19
	Weekly	\$ 1,291.11	\$ 1,549.33	\$ 1,807.55
	Annual	\$ 67,395.92	\$ 80,875.11	\$ 94,354.29
8	Hourly	\$ 35.02	\$ 42.03	\$ 49.03
	Weekly	\$ 1,400.85	\$ 1,681.02	\$ 1,961.20
	Annual	\$ 73,124.58	\$ 87,749.49	\$ 102,374.41
9	Hourly	\$ 38.00	\$ 45.60	\$ 53.20
	Weekly	\$ 1,519.93	\$ 1,823.91	\$ 2,127.90
	Annual	\$ 79,340.17	\$ 95,208.20	\$ 111,076.23
10	Hourly	\$ 41.23	\$ 49.47	\$ 57.72
	Weekly	\$ 1,649.12	\$ 1,978.94	\$ 2,308.77
	Annual	\$ 86,084.08	\$103,300.90	\$ 120,517.71
11	Hourly	\$ 44.73	\$ 53.68	\$ 62.63
	Weekly	\$ 1,789.30	\$ 2,147.15	\$ 2,505.01
	Annual	\$ 93,401.23	\$112,081.47	\$ 130,761.72
12	Hourly	\$ 48.53	\$ 58.24	\$ 67.95
	Weekly	\$ 1,941.39	\$ 2,329.66	\$ 2,717.94
	Annual	\$101,340.33	\$121,608.40	\$ 141,876.46
13	Hourly	\$ 52.66	\$ 63.19	\$ 73.72
	Weekly	\$ 2,106.40	\$ 2,527.68	\$ 2,948.96
	Annual	\$109,954.26	\$131,945.11	\$ 153,935.96
14	Hourly	\$ 57.14	\$ 68.56	\$ 79.99
	Weekly	\$ 2,285.45	\$ 2,742.54	\$ 3,199.63
	Annual	\$119,300.37	\$143,160.44	\$ 167,020.52
15	Hourly	\$ 61.80	\$ 74.16	\$ 86.51
	Weekly	\$ 2,471.84	\$ 2,966.21	\$ 3,460.57
	Annual	\$129,030.00	\$154,836.00	\$ 180,642.00

Proposed Equipment and Capital Purchases for FY 2024

			PBC Recommendations	Sustainability Committee Recommendation
1	IT Hardware	\$27,000		
2	New Automated Trash Collection - Trash and Recycling Bins	\$310,000		
3	Replace Police Department Tasers and Cartridges	\$17,000		
4	Handheld Radar Police Department	\$5,000		
5	CPR Machines Fire Department	\$44,200		
6	Electronic Handheld Voting Devices Town Meeting	\$12,000		
7	Spofford School Flooring Year 2	\$90,000	Yes	
8	Spofford School - Feasibility and Design HVAC Electrification	\$75,000	Yes	Yes
9	Engineering Design Services for New DPW Facility Phase II - Schematic	\$248,000	Yes	
	Total ARTICLE 11	\$828,200		

From: [Steve Clifford](#)
To: [Matt Coogan](#)
Cc: [Scott Morrison](#); [Steve Greenberg](#)
Subject: Boxford Schools Security Video Projects
Date: Friday, April 21, 2023 3:29:10 PM
Attachments: [Harry Lee Cole SecVid-042123.pdf](#)
[Spofford Pond School - SecVid-042123.pdf](#)

External Sender

Good Afternoon Matt,

Please see attached estimates related to the security video projects that we have been discussing funding at the upcoming annual town meeting. At this time I am adding a 20% contingency to each estimate while we iron out some final technical details and get you project estimates as requested by today. I expect to modify the total cost of each project's cost lower but wanted to have these costs as a placeholder for your process. Any questions related to these estimates or the projects in general please contact me directly.

Cole School = 81,324.00
Spofford Pond School = \$62,158.00

Thank you,
Steve

Steve Clifford
Director of Facilities

Boxford Public Schools
Middleton Public Schools
Topsfield Public Schools
Office - 978-887-0771 ext.225
Fax - 978-887-8042



***CONNECTING & PROTECTING THE
FUTURE***

Structured Cabling • Integrated Security
• IT Infrastructure • A/V

**LAN-TEL Communications,
Inc.**

**3 Edgewater Drive
Norwood, MA 02062**



LAN-TEL Communications, Inc.
3 Edgewater Drive
Norwood, MA 02062
Phone: 781.551.8599
Fax: 781.551.8667 www.lan-tel.com

Date: **April 13, 2023**

To: Mr. Scott Morrison
Superintendent
Boxford Public Schools
28 Middleton Rd
Boxford, MA 01921

From: **John M Grennon**
LAN-TEL Communications, Inc.
Phone: (857) 939-8181
jgrennon@lan-tel.com

Re: Security Upgrades at the Spofford Pond School
31 Spofford Rd. Boxford, MA.

Thank you for the opportunity to present LAN-TEL Communications, Inc.'s quote for the requested security upgrades and enhancements at the Spofford Pond School, located at 31 Spofford Rd. Boxford, MA

Our quote is based upon the information gathered during a site visit conducted by John Grennon of Lan-Tel Communications, Matt Leonard of Avigilon and Steven Clifford of the Tri-Town School Union.

I am hopeful you will find our response to reflect our understanding and interpretation of the security scope and that the financial offer is within your budget allocation.

If you have any questions, please call me at (857) 939-8181 or e-mail me at jgrennon@lan-tel.com. I look forward to reviewing our proposal with you.

Regards,
John M Grennon

Connecting & Protecting the Future
Structured Cabling • Integrated Security • IT Infrastructure • A/V



Scope of Work

Lan-Tel Communications will furnish and install the following IP Camera and Video upgrades at the Spofford Pond School

Four (4) Avigilon 270-degree IP exterior cameras

One (1) Avigilon Exterior Mini Dome camera

Three (3) Avigilon Interior 180-degree IP cameras

One (1) Avigilon Interior 360-degree IP camera

Five (5) Avigilon Interior Mini Dome cameras

One (1) Avigilon 16 TB, rack mounted, Network Video Recorder

Two (2) 42 Inch Video Monitors

One (1) Remote Monitoring Workstation 2 Monitors ACC Client pre-installed

Lan-Tel Communications will provide all required Avigilon base and edge device licensing for all installed cameras.

Lan-Tel Communications will furnish and install all necessary Category 6 cable associated with this installation.

All work will be performed by Lan-Tel Communications Technicians. Subcontractors will not be utilized for this project.

This installation will be covered by a 1-year, material and labor warranty. In addition, all Avigilon equipment will be covered by a 5-year warranty.

Lan-Tel Communications will provide 4 hours of end user training on the Avigilon Control Center System. This training will be conducted at the Spofford Pond School and the date and time will be at the discretion of the Tri-Town School Union.

QTY:	Manufacturer:	PART#	Description:
			Cabling Scope
3000	General	7131800	CAT6 PLENUM BLUE GENSPEED 6
50	Garvin	JHK-32	J-HOOK, 2"
1	Hilti	50352	Gridwire Shots (100 ct)
1	Cert Conn	SWP612	Pretied Ceiling Wire With Pin; 6 ft, Silver 100
1	LAN-TEL	LAN-TEL	Firestop Material
1	Velcro	189645	75' Velcro
15	Cert Conn	12B2103	PATCH CORD CAT 6 3FT BLUE
2	Ortronics	PHD66U24HM	Clarity 6 hinged 24-port panel with lower cable management panel, Cat6, six-port modules, 19" x 3.5"
			Cabling Scope
Qty:	Manufacturer:	Part Number:	CCTV Scope
1	Avigilon	NVR5-STD-16TB-W10-NA	NVR5 Standard 16 TeraBytes 2U Rack Mount, W10 NA
4	Avigilon	15C-H4A-3MH-270	3x 5 MP, WDR, LightCatcher, 2.8mm, Camera Only
1	Avigilon	4.0C-H5A-DP1-IR	4.0 MP WDR, LightCatcher, Day/Night, Pendant Dome, 3.3-9mm f/1.3 P-iris lens, Integrated IR, Next-Generation Analytics. Must use with a H4A-MT-Wall1 or H4A-MT-NPTA1.
3	Avigilon	6.0C-H5DH-DO1-IR	2x 3MP H5A Dual Head Camera. Outdoor camera with built-in IR
1	Avigilon	9C-H4A-3MH-180	3x 3 MP, WDR, LightCatcher, 4mm, Camera Only
1	Avigilon	12C-H4A-4MH-360	4x 3 MP, WDR, LightCatcher, 2.8mm, Camera Only
5	Avigilon	3.0C-H6M-D1-IR	3.0 MP, H6 Mini Dome Camera, WDR, LightCatcher, Day/Night, 2.9mm f/2.0, IR
15	Avigilon	ACC7-ENT	ACC 7 Enterprise camera channel
4	Avigilon	H4AMH-AD-PEND1	Outdoor pendant mount adapter, must order one of IRPTZ-MNT-Wall1 or IRPTZ-MNT-NPTA1 and one of H4AMH-DO-COVR1 or H4AMH-DO-COVR1-SMOKE.
4	Avigilon	H4AMH-DO-COVR1	Outdoor Dome Cover for H4 Multisensor
4	Avigilon	IRPTZ-MNT-WALL1	Pedant wVideo mount adapter. For use with H4 IR PTZ or H4A-MH-AD-PEND1 on H4 Multisensor.
4	Avigilon	H4-MT-CRNR1	Corner mount adapter for use with H4A-MT-Wall1, H4-BO-JBOX1, H4SL, H4F, H4 PTZ, H4 IR PTZ and H4 Multisensor cameras.
4	Avigilon	H4AMH-AD-IRIL1	Optional IR illuminator ring, up to 30m (100ft), for use with H4AMH-DO-COVR1.
1	Avigilon	H4A-MT-WALL1	Wall mount bracket for use with H5A/H4A pendant dome cameras
1	Avigilon	H5DH-DO-JBOX1	Junction Box for H5A Dual Head Camera
1	Avigilon	H4AMH-AD-PEND1	Outdoor pendant mount adapter, must order one of IRPTZ-MNT-Wall1 or IRPTZ-MNT-NPTA1 and one of H4AMH-DO-COVR1 or H4AMH-DO-COVR1-SMOKE.

1	Avigilon	H4AMH-DO-COVR1	Outdoor Dome Cover for H4 Multisensor
1	Avigilon	IRPTZ-MNT-WALL1	Pedant wVideo mount adapter. For use with H4 IR PTZ or H4A-MH-AD-PEND1 on H4 Multisensor.
1	Avigilon	H4AMH-AD-DOME1	Outdoor surface mount adapter, must order either a H4AMH-DO-COVR1 or H4AMH-DO-COVR1-SMOKE.
1	Avigilon	H4AMH-DO-COVR1	Outdoor Dome Cover for H4 Multisensor
4	Avigilon	POE-INJ2-60W-NA	Indoor single port Gigabit PoE++ 60W, North American power cord included. Temperature range of the PoE injector is -10C to +45C (14 °F to 113 °F). When used with the H4 IR PTZ, the camera will operate in a reduced temperature range from -10 °C to +50 °C (14°F to 122 °F).
2	Neatgear	GS524PP	24-Port Gigabit Ethernet Unmanaged PoE Switch with 24 x PoE+ @ 300W, Desktop or Rackmount, and Limited Lifetime Protection
2	ViewSonic	VX4381-4K	43 Inch Ultra HD MVA 4K Monitor Widescreen with HDR10 Support, Eye Care, HDMI, USB, DisplayPort
1	Avigilon	RM5-WKS-2MN-NA	Remote Monitoring Workstation 2 Monitors ACC Client pre-installed
1	LAN-TEL	LAN-TEL-CABLES	Misc cables for workstations, monitors
2	Vertiv	PST5-850MT120	UPS backup protection for workstations and surveillance systems
15			CCTV Scope
			Programming and Commissioning
1	LAN-TEL	LAN-TEL-SVCS	Video System Programming
			Programming and Commissioning
			Misc/Admin Time/Documentation
1	LAN-TEL	LAN-TEL	Misc Materials
1	LAN-TEL	LAN-TEL	Coordination, Documentation, Meetings
			Misc/Admin Time/Documentation
			Materials Handling
1	LAN-TEL	LAN-TEL	Materials Handling/Deliveries
			Materials Handling
			Testing and Training
1	LAN-TEL	LAN-TEL	CCTV Testing and Re-aiming
			Testing and Training

Pricing Structure

Material:	\$	40,997.00
Labor:	\$	10,801.00
Total	\$	51,798.00

Terms & Conditions

LAN-TEL Communications, Inc., having its place of business at 3 EDGEWATER DRIVE, Norwood, MA 02062, (hereinafter referred to as "LAN-TEL") sets forth the following terms and conditions to which Purchaser and LAN-TEL agree:

1. LAN-TEL agrees to provide and install all equipment as specified in accordance with manufactures specifications. All equipment will be installed in a workmanlike manner. LAN-TEL reserves the right to substitute equipment based upon installation constraints or delivery requirements.
2. Purchaser shall be responsible to provide 110VAC power as required.
3. All labor is under warranty by Lan-Tel Communications for the period of 12 months to be free of defects in material and manufacturing. This shall include on-site support including parts and labor. Warranty service is available from 8:30 a.m. to 4:30 p.m. Monday through Friday excluding holidays. Out of hours service is available for a labor charge.
4. Services required to correct conditions caused by lightning, fire, flood or other acts of God, or by equipment outside the scope of this agreement, misuse, abuse or vandalism are specifically excluded from this agreement, and are billable at current rates.
5. This quote is good for (30) thirty days.

LAN-TEL Communications, Inc.

Boxford Public Schools

By: **John M Grennon**

Date: **April 13, 2023**



About LAN-TEL Communications, Inc.

LAN-TEL is the industry leader and trusted provider of structured cabling systems, integrated public safety and security solutions and IT infrastructure services. For more than 25 years, LAN-TEL has offered an unparalleled level of client service, support and innovative technologies to New England's largest corporations, buildings and municipalities.

Decades of Telecommunications Experience

LAN-TEL has been providing telecommunication wiring services to customers in New England since 1991. Our team of experienced technicians and project managers are trained and certified to install and maintain all low voltage solutions; from traditional copper-based infrastructure to cutting-edge fiber solutions. The LAN-TEL team brings expertise throughout every phase of your project. LAN-TEL is an active member of the Building Industry Consulting Services International (BICSI) and is qualified and certified to build and test to current Electronic Industries Alliance (EIA), and Telecommunications Industry Association (TIA) standards. Our team of Registered Communications Distribution Designers (RCDD), Project Managers, and Engineers ensure your network infrastructure will utilize the latest design/installation techniques and comply with all state/local licensing requirements and building codes.

Security Teams Trusted by Top Law Enforcement

LAN-TEL is New England's relied upon security system provider, having provided hundreds of hardwired and wireless video security system installations throughout New England. At our Norwood headquarters, in our prefabrication department's special IP Lab, technicians efficiently customize security cameras and switches to precise specifications for New England's largest Police Departments, Corporations, Schools and clients. All security cameras undergo thorough pretesting prior to being delivered and installed on-site. LAN-TEL technicians provide reliable installations and maintenance of systems in a variety of field conditions, 24-7, whenever the call comes in.

Unmatched IT Infrastructure Services

LAN-TEL offers IT Infrastructure solutions from a talented team of experienced professionals. LAN-TEL Communications' IT infrastructure group provides end-to-end solutions; from the physical cabling, to data center infrastructure, and full integration of security systems. LAN-TEL Communications is a one-stop shop for all your IT infrastructure needs. As your most trusted adviser, LAN-TEL Communications has partnered with the best-of-breed IT hardware and software providers to offer the latest solutions.

Connecting & Protecting the Future
Structured Cabling • Integrated Security • IT Infrastructure • A/V





***CONNECTING & PROTECTING THE
FUTURE***

Structured Cabling • Integrated Security
• IT Infrastructure • A/V

**LAN-TEL Communications,
Inc.**

**3 Edgewater Drive
Norwood, MA 02062**



LAN-TEL Communications, Inc.
3 Edgewater Drive
Norwood, MA 02062
Phone: 781.551.8599
Fax: 781.551.8667 www.lan-tel.com

Date: **April 13, 2023**

To: Mr. Scott Morrison
Superintendent
Boxford Public Schools
28 Middleton Rd
Boxford, MA 01921

From: **John M Grennon**
LAN-TEL Communications, Inc.
Phone: (857) 939-8181
jgrennon@lan-tel.com

Re: Security Upgrades at the Harry Lee Cole School
26 Middleton Rd. Boxford, MA.

Thank you for the opportunity to present LAN-TEL Communications, Inc.'s quote for the requested security upgrades and enhancements at the Harry Lee Cole School, located at 26 Middleton Rd. Boxford, MA.

Our quote is based upon the information gathered during a site visit conducted by John Grennon of Lan-Tel Communications, Matt Leonard of Avigilon and Steven Clifford of the Tri-Town School Union.

I am hopeful you will find our response to reflect our understanding and interpretation of the security scope and that the financial offer is within your budget allocation.

If you have any questions, please call me at (857) 939-8181 or e-mail me at jgrennon@lan-tel.com. I look forward to reviewing our proposal with you.

Regards,
John M Grennon

Connecting & Protecting the Future
Structured Cabling • Integrated Security • IT Infrastructure • A/V



Scope of Work

Lan-Tel Communications will furnish and install the following IP Camera and Video upgrades at the Harry Lee Cole School

Four (4) Avigilon 270-degree IP exterior cameras

One (1) Avigilon Exterior Mini Dome camera

Six (6) Avigilon Interior 180-degree IP cameras

Ten (10) Avigilon Interior Mini Dome cameras

One (1) Avigilon Interior 360-degree IP camera

Two (2) 42 Inch Video Monitors

One (1) Remote Monitoring Workstation 2 Monitors ACC Client pre-installed

Lan-Tel Communications will provide all required Avigilon base and edge device licensing for all installed cameras.

Lan-Tel Communications will furnish and install all necessary Category 6 cable associated with this installation.

All work will be performed by Lan-Tel Communications Technicians. Subcontractors will not be utilized for this project.

This installation will be covered by a 1-year, material and labor warranty. In addition, all Avigilon equipment will be covered by a 5-year warranty.

Lan-Tel Communications will provide 4 hours of end user training on the Avigilon Control Center System. This training will be conducted at the Harry Lee Cole School and the date and time will be at the discretion of the Tri-Town School Union.

QTY:	Manufacturer:	PART#	Description:
			Cabling Scope
5000	General	7131800	CAT6 PLENUM BLUE GENSPEED 6
100	Garvin	JHK-32	J-HOOK, 2"
1	Hilti	50352	Gridwire Shots (100 ct)
1	Cert Conn	SWP612	Pretied Ceiling Wire With Pin; 6 ft, Silver 100
1	LAN-TEL	LAN-TEL	Firestop Material
1	Velcro	189645	75' Velcro
22	Cert Conn	12B2103	PATCH CORD CAT 6 3FT BLUE
2	Ortronics	PHD66U24HM	Clarity 6 hinged 24-port panel with lower cable management panel, Cat6, six-port modules, 19" x 3.5"
			Cabling Scope
Qty:	Manufacturer:	Part Number:	CCTV Scope
1	Avigilon	NVR5-STD-24TB-W10-NA	NVR5 STD 24TB 2U Rack Mnt, W10 NA
4	Avigilon	15C-H4A-3MH-270	3x 5 MP, WDR, LightCatcher, 2.8mm, Camera Only
1	Avigilon	4.0C-H5A-DP1-IR	4.0 MP WDR, LightCatcher, Day/Night, Pendant Dome, 3.3-9mm f/1.3 P-iris lens, Integrated IR, Next-Generation Analytics. Must use with a H4A-MT-Wall1 or H4A-MT-NPTA1.
6	Avigilon	9C-H4A-3MH-180	3x 3 MP, WDR, LightCatcher, 4mm, Camera Only
1	Avigilon	12C-H4A-4MH-360	4x 3 MP, WDR, LightCatcher, 2.8mm, Camera Only
10	Avigilon	3.0C-H6M-D1-IR	3.0 MP, H6 Mini Dome Camera, WDR, LightCatcher, Day/Night, 2.9mm f/2.0, IR
22	Avigilon	ACC7-ENT	ACC 7 Enterprise camera channel
4	Avigilon	H4AMH-AD-PEND1	Outdoor pendant mount adapter, must order one of IRPTZ-MNT-Wall1 or IRPTZ-MNT-NPTA1 and one of H4AMH-DO-COVR1 or H4AMH-DO-COVR1-SMOKE.
4	Avigilon	H4AMH-DO-COVR1	Outdoor Dome Cover for H4 Multisensor
4	Avigilon	IRPTZ-MNT-WALL1	Pedant wVideo mount adapter. For use with H4 IR PTZ or H4A-MH-AD-PEND1 on H4 Multisensor.
4	Avigilon	H4-MT-CRNR1	Corner mount adapter for use with H4A-MT-Wall1, H4-BO-JBOX1, H4SL, H4F, H4 PTZ, H4 IR PTZ and H4 Multisensor cameras.
4	Avigilon	H4AMH-AD-IRIL1	Optional IR illuminator ring, up to 30m (100ft), for use with H4AMH-DO-COVR1.
1	Avigilon	H4A-MT-WALL1	Wall mount bracket for use with H5A/H4A pendant dome cameras
6	Avigilon	H4AMH-AD-PEND1	Outdoor pendant mount adapter, must order one of IRPTZ-MNT-Wall1 or IRPTZ-MNT-NPTA1 and one of H4AMH-DO-COVR1 or H4AMH-DO-COVR1-SMOKE.
6	Avigilon	H4AMH-DO-COVR1	Outdoor Dome Cover for H4 Multisensor

6	Avigilon	IRPTZ-MNT-WALL1	Pedant wVideo mount adapter. For use with H4 IR PTZ or H4A-MH-AD-PEND1 on H4 Multisensor.
1	Avigilon	H4AMH-AD-DOME1	Outdoor surface mount adapter, must order either a H4AMH-DO-COVR1 or H4AMH-DO-COVR1-SMOKE.
1	Avigilon	H4AMH-DO-COVR1	Outdoor Dome Cover for H4 Multisensor
4	Avigilon	POE-INJ2-60W-NA	Indoor single port Gigabit PoE++ 60W, North American power cord included. Temperature range of the PoE injector is -10C to +45C (14 °F to 113 °F). When used with the H4 IR PTZ, the camera will operate in a reduced temperature range from -10 °C to +50 °C (14°F to 122 °F).
2	Neatgear	GS524PP	24-Port Gigabit Ethernet Unmanaged PoE Switch with 24 x PoE+ @ 300W, Desktop or Rackmount, and Limited Lifetime Protection
2	ViewSonic	VX4381-4K	43 Inch Ultra HD MVA 4K Monitor Widescreen with HDR10 Support, Eye Care, HDMI, USB, DisplayPort
1	Avigilon	RM5-WKS-2MN-NA	Remote Monitoring Workstation 2 Monitors ACC Client pre-installed
1	LAN-TEL	LAN-TEL-CABLES	Misc cables for workstations, monitors
2	Vertiv	PST5-850MT120	UPS backup protection for workstations and surveillance systems
CCTV Scope			
Programming and Commissioning			
1	LAN-TEL	LAN-TEL-SVCS	Video System Programming
Programming and Commissioning			
Misc/Admin Time/Documentation			
1	LAN-TEL	LAN-TEL	Misc Materials
1	LAN-TEL	LAN-TEL	Coordination, Documentation, Meetings
Misc/Admin Time/Documentation			
Materials Handling			
1	LAN-TEL	LAN-TEL	Materials Handling/Deliveries
Materials Handling			
Testing and Training			
1	LAN-TEL	LAN-TEL	CCTV Testing and Re-aiming
Testing and Training			

Pricing Structure

Material:	\$	51,704.00
Labor:	\$	16,066.00
Total	\$	67,770.00

Terms & Conditions

LAN-TEL Communications, Inc., having its place of business at 3 EDGEWATER DRIVE, Norwood, MA 02062, (hereinafter referred to as "LAN-TEL") sets forth the following terms and conditions to which Purchaser and LAN-TEL agree:

1. LAN-TEL agrees to provide and install all equipment as specified in accordance with manufactures specifications. All equipment will be installed in a workmanlike manner. LAN-TEL reserves the right to substitute equipment based upon installation constraints or delivery requirements.
2. Purchaser shall be responsible to provide 110VAC power as required.
3. All labor is under warranty by Lan-Tel Communications for the period of 12 months to be free of defects in material and manufacturing. This shall include on-site support including parts and labor. Warranty service is available from 8:30 a.m. to 4:30 p.m. Monday through Friday excluding holidays. Out of hours service is available for a labor charge.
4. Services required to correct conditions caused by lightning, fire, flood or other acts of God, or by equipment outside the scope of this agreement, misuse, abuse or vandalism are specifically excluded from this agreement, and are billable at current rates.
5. This quote is good for (30) thirty days.

LAN-TEL Communications, Inc.

Boxford Public Schools

By: **John M Grennon**

Date: **April 13, 2023**



About LAN-TEL Communications, Inc.

LAN-TEL is the industry leader and trusted provider of structured cabling systems, integrated public safety and security solutions and IT infrastructure services. For more than 25 years, LAN-TEL has offered an unparalleled level of client service, support and innovative technologies to New England's largest corporations, buildings and municipalities.

Decades of Telecommunications Experience

LAN-TEL has been providing telecommunication wiring services to customers in New England since 1991. Our team of experienced technicians and project managers are trained and certified to install and maintain all low voltage solutions; from traditional copper-based infrastructure to cutting-edge fiber solutions. The LAN-TEL team brings expertise throughout every phase of your project. LAN-TEL is an active member of the Building Industry Consulting Services International (BICSI) and is qualified and certified to build and test to current Electronic Industries Alliance (EIA), and Telecommunications Industry Association (TIA) standards. Our team of Registered Communications Distribution Designers (RCDD), Project Managers, and Engineers ensure your network infrastructure will utilize the latest design/installation techniques and comply with all state/local licensing requirements and building codes.

Security Teams Trusted by Top Law Enforcement

LAN-TEL is New England's relied upon security system provider, having provided hundreds of hardwired and wireless video security system installations throughout New England. At our Norwood headquarters, in our prefabrication department's special IP Lab, technicians efficiently customize security cameras and switches to precise specifications for New England's largest Police Departments, Corporations, Schools and clients. All security cameras undergo thorough pretesting prior to being delivered and installed on-site. LAN-TEL technicians provide reliable installations and maintenance of systems in a variety of field conditions, 24-7, whenever the call comes in.

Unmatched IT Infrastructure Services

LAN-TEL offers IT Infrastructure solutions from a talented team of experienced professionals. LAN-TEL Communications' IT infrastructure group provides end-to-end solutions; from the physical cabling, to data center infrastructure, and full integration of security systems. LAN-TEL Communications is a one-stop shop for all your IT infrastructure needs. As your most trusted adviser, LAN-TEL Communications has partnered with the best-of-breed IT hardware and software providers to offer the latest solutions.

Connecting & Protecting the Future
Structured Cabling • Integrated Security • IT Infrastructure • A/V





Eagle Scout Service Project Proposal



BOY SCOUTS OF AMERICA®

Eagle Scout candidate's full legal name Charlie Posanka

Please give a name to your project Public Bike Repair Station

Instructions for Preparing Your Proposal

Meeting the Five Tests of an Acceptable Eagle Scout Service Project

Your proposal must be prepared first. It is an overview, but also the beginnings of planning. It must show your unit leader, unit committee, and council or district that your project can meet the following tests.

- 1. It provides sufficient opportunity to meet the Eagle Scout service project requirement.** You must show that planning, development, and leadership will take place; and how the three factors will benefit a religious institution, a school, or your community.
- 2. It appears to be feasible.** You must show the project is realistic for you to carry out.
- 3. Safety issues will be addressed.** You must show you have an understanding of what must be done to guard against injury, and what will be done if someone gets hurt.
- 4. Action steps for further detailed planning are included.** You must make a list of the key steps you will take to make sure your plan will have enough details so it can be carried out successfully.
- 5. You are on the right track with a reasonable chance for a positive experience.**

When completing your proposal you only need enough detail to show a reviewer that you can meet the tests above. If showing that you meet the tests requires a lengthy and complicated proposal, your project might be more complex than necessary. Remember, the proposal is only the beginnings of planning. Most of your planning will come with the next step, preparation of your project plan.

If your project does not require materials or supplies, etc., simply mark those spaces "not applicable." As a reminder, do not begin any work, or raise any money, or obtain any materials, until your project proposal has been approved.

Consider also, that if you submit your proposal too close to your 18th birthday, it may not be approved in time to finish planning and executing the project.

Working with Your Project Beneficiary

On the last two pages of this workbook there is an information sheet called, "Navigating the Eagle Scout Service Project." This is for you to print and give to the religious institution, school, or community that will benefit from your efforts. You should do this as part of your first meeting with your beneficiary and use the sheet to help explain how the Eagle Scout service project works. Be sure to read it carefully so you can explain what it says.

"Navigating the Eagle Scout Service Project" will help you communicate a number of things to your beneficiary. For example, it provides thanks and congratulations for accepting the project; and it gives some background, discusses the requirements, and points out the responsibilities connected with approving your project proposal. It also explains that the beneficiary has the right to review, and also to require changes in your project plan.

Again, be sure to read carefully "Navigating the Eagle Scout Service Project" so you will have a full understanding of the role of your beneficiary.

Next Step: Your Project Plan

Once your proposal is approved, you are **strongly encouraged** to prepare your project plan using the form in this workbook. Doing so increases the likelihood your project will be approved at your Eagle Scout board of review. As you begin preparing it, you should meet with a project coach. Check with the person who handled the approval of your project proposal to learn how coaches are designated in your community.

Your designated coach can help you avoid the common pitfalls associated with Eagle Scout service projects and be a big part of your success. You may also want to talk to your unit leader. There may be adults in your troop who are experts in conducting the kind of project you are planning. It's ok for you to work with them as well. The more coaching you get, the better your results will be.

Beginning Work on Your Project

Once your proposal has been fully approved and you have finished your project planning, only then, may you begin work on your project.

Contact Information

Eagle Scout candidates should know who is involved, but contact information may be more important to unit leaders and others in case they want to talk to each other. While it is recognized that not all the information will be needed for every project, Scouts are expected to provide as much as reasonably possible. Approval representatives must understand, however, that doing so is not part of the service project requirement.

Eagle Scout Candidate

Name: Charlie Posanka		Birth date: 6/5/06	
Email Address: cposanka@gmail.com		BSA PID number: 129298799	
Address: 18 Mill Run Road	City: Boxford	State: MA	Zip: 01921
Preferred telephone(s): 978-380-3825		Life Board of Review date: June 5, 2021	

Current Unit Information

Check One: <input checked="" type="radio"/> Troop <input type="radio"/> Crew <input type="radio"/> Ship	Unit Number: Troop 51
Name of District: Great Eastern	Name of Council: Spirit of Adventure

Unit Leader Check One: Scoutmaster Crew Advisor Skipper

Name: Michael Posanka		Preferred telephone(s): 617-459-9001	
Address: 18 Mill Run Road	City: Boxford	State: MA	Zip: 01921
Email Address: mposanka@yahoo.com			

Unit Committee Chair

Name: Sean Flynn		Preferred telephone(s): 617-823-8177	
Address: 123 Highridge Road	City: Boxford	State: MA	Zip: 01921
Email Address: sflynn9@gmail.com			

Unit Advancement Coordinator *(If your unit has one)*

Name: Dan Allis		Preferred telephone(s): 617-821-2631	
Address: 41 Highland Road	City: Boxford	State: MA	Zip: 01921
Email Address: daniel.allis2009@gmail.com			

Project Beneficiary *(Name of religious institution, school or community)*

Name: Town of Boxford		Preferred telephone(s): 978-861-1014	
Address: 7 Spofford Road	City: Boxford	State: MA	Zip: 01921
Email Address: Not provided			

Project Beneficiary Representative *(Name of contact person for the project beneficiary)*

Name: Matthew Coogan		Preferred telephone(s): 978-861-1014	
Address: 7 Spofford Road	City: Boxford	State: MA	Zip: 01921
Email Address: Not provided			

Your Council Service Center

Contact Name:	Preferred telephone(s):		
Address:	City:	State:	Zip:
Email Address:			

Council or District Project Approval Representative *(Your unit leader, unit advancement coordinator, or council or district advancement chair may help you learn who this will be.)*

Name:		Preferred telephone(s):	
Address:	City:	State:	Zip:
Email Address:			

Project Coach *(Your council or district project approval representative may help you learn who this will be.)*

Name: Tim O'Brien		Preferred telephone(s): 978-766-5814	
Address: 5 Endicott Road	City: Boxford	State: MA	Zip: 01921
Email Address: tobrien@comcast.net			

Giving Leadership

Approximately how many people will be needed to help on your project?

Where will you recruit them (unit members, friends, neighbors, family, others)?

- Once the project is approved, I will speak to my troop, as well as the local bike teams for fundraising
- Once I have the stand and the materials needed for installation purchased, I will once again speak to my troop about the installation process
- Since this will most likely be in the summer, and my troop will no longer be meeting regularly, I will address it in an email

What do you think will be most difficult about leading them?

- I will need the assistance of someone who has experience with concrete and tools, so that I can learn how to mix and pour concrete.

Materials

Materials are things that become part of the finished project, such as lumber, nails and paint.

What types of materials, if any, will you need? You do not need a detailed list or exact quantities, but you must show you have a reasonable idea of what is required. For example, for lumber, use basic dimensions such as 2x4 or 4x4.

After looking at the instructions of the stand that was donated, the materials that are included that I need to consider for the next stand include:

- Main body (6" x .154" tube)
- Bike Hanger (1.5" sch. 40 pipe, 1/4" plate)
- Stand foot (10" dia. x 25" plate)
- Tool tethers (5/32" stainless steel cables)
- Manuel air pump

Supplies

Supplies are things you use up, such as food and refreshments, gasoline, masking tape, tarps, safety supplies and garbage bags.

What types of supplies, if any, will you need? You do not need a detailed list or exact quantities, but you must show you have a reasonable idea of what is required.

- Concrete (roughly 14 cubic feet)
- Water and food for scouts

Tools

Include tools, and also equipment, that will be borrowed, rented, or purchased.

What tools or equipment, if any, will you need? You do not need a detailed list, but you must show you have a reasonable idea of what is required.

After looking at the instructions and the list of tools for the donated stand, the tools I will need are: - Philips and flat head screwdrivers - 2.5, 3, 4, 5, 6, 8mm Allen wrenches - Headset wrench - Pedal wrench - 8, 9, 10, 11mm box wrenches - Tire levers - Marker or pencil - Masonry Drill Bit (3/8") - Drill - Hammer - Wrench (9/16") - Level - shovel

Other Needs

Items that don't fit the above categories; for example, parking or postage, or services such as printing or pouring concrete, etc..

What other needs do you think you might encounter?

Permits and Permissions

Note that property owners should obtain and pay for permits.

Will permissions or permits (such as building permits) be required for your project? Who will obtain them? How long will it take?

- I will need to get permission from the Town of Boxford, as the beneficiary. - I will need to get official permission from Fire Chief Geiger to use land at the fire station - I will need approval from Police Chief Riter to use his donated stand at the police station - I already talked to everyone listed above, and they are all enthusiastic. I also already have in possession the stand that was donated by Chief Riter

Preliminary Cost Estimate

You do not need exact costs yet. Reviewers will just want to see if you can reasonably expect to raise enough money to cover an initial estimate of expenses. Include the value of donated materials, supplies, tools, and other items. It is not necessary to include the value of tools or other items that will be loaned at no cost. Note that if your project requires a fundraising application, you do not need to submit it with your proposal.

Enter your estimated expenses below
(Include sales tax if applicable)

Materials:
 Supplies:
 Tools:
 Other:
 Total Costs:

Fundraising: Explain how you will raise the money to pay for the total costs. If you intend to seek donations of actual materials, supplies, etc., then explain how you plan to do that, too.

I will start a GoFundMe. I will advertise it through the Scout Troop, as well as the various local cycling clubs, such as my own.

Project Phases

Think of your project in terms of phases, and list what they might be. The first may be to prepare your project plan. Other phases might include fundraising, preparation, execution and reporting. You may have as many phases as you want, but it is not necessary to become overly complicated; brief, one line descriptions are sufficient. If you have more than 10 phases, attach a separate page with your continued phase list.

1	Planning
2	Fundraising
3	Preparation for installation
4	Installation
5	Reports
6	
7	
8	
9	
10	

Logistics

How will you handle transportation of materials, supplies, tools, and helpers?

All of these materials, supplies, and tools can fit in the back of a car. The scouts might need their own form of transportation, but the only transportation that is needed is from 1 station location to the other

Safety Issues

The Guide to Safe Scouting is an important resource in considering safety issues.

Describe the hazards and safety concerns of which you and your helpers should be aware.

Read the "Age Guidelines for Tool Usage" at Scouting.org

The only thing that will be dangerous is the use of the drill. I will need adult supervision. I will also need to get in touch with DigSafe to make sure it is safe

Project Planning

You do not have to list every step, but it must be enough to show you have a reasonable idea of how to prepare your plan.

List some action steps you will take to prepare your project plan. For example, "Complete a more detailed set of drawings."

I will get the proposal approved. Once that is approved, I will finish my planning. Next, I will start and advertise a GoFundMe throughout the rest of the spring. Once I have the money, I will purchase everything that I need. I will once again speak to my troop about my project, specifically asking for help with the installation process. Once I have the scout troop helping, I will install these stands

Project Description and Benefit

Briefly describe your project

Install public bike repair stations in Boxford. I will be installing 2 stations. One stand was generously donated by Chief Jim Riter. Chief Riter is the chief of police in Boxford. He would like it to be installed by the police station. I plan to install the second station at the East Fire Station. I have already talked to Chief Geiger. These stations have several tools on them that can repair parts on a bike.

Include images on an additional document.

Tell how your project will be helpful to the beneficiary. Why is it needed?

- There are various cycling groups and individuals in Boxford, some of which meet where I intend to put these stations. If a part on their bikes breaks, they will be able to fix it with the tools provided on the stand.

When do you plan to begin carrying out your project?

I plan to start fundraising in May

When do you think your project will be completed?

I plan to finish by October

Caution: Using an Adobe or other PDF reader to insert a "signature" can cause this entire document's contents to be locked preventing future edits; make sure you save a copy if any signatures will be inserted digitally.

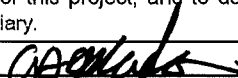
Candidate's Promise*		<i>Sign below before you seek the other approvals for your proposal.</i>
On my honor as a Scout, I have read this entire workbook, including the "Message to Scouts and Parents or Guardians" on page 4. I promise to be the leader of this project, and to do my best to carry it out for the maximum benefit to the religious institution, school, or community I have chose as beneficiary.		
Signed 	Date	

* Remember: Do not begin any work on your project, or raise any money, or obtain any materials, until your project has been approved.

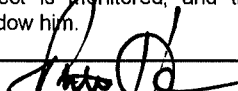
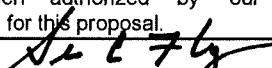
Unit Leader Approval*		Unit Committee Approval*	
I have reviewed this proposal and discussed it with the candidate. I believe it provides impact worthy of an Eagle Scout service project, and will involve planning, development and leadership. I am comfortable the Scout understands what to do, and how to lead the effort. I will see that the project is monitored, and that adults or others present will not overshadow him.		This Eagle Scout candidate is a Life Scout, and registered in our unit. I have reviewed this proposal, I am comfortable the project is feasible, and I will do everything I can see that our unit measures up to the level of support we have agreed to provide (if any). I certify that I have been authorized by our unit committee to provide its approval for this proposal.	
Signed 	Date <u>Apr. 10, 2023</u>	Signed 	Date <u>4/10/23</u>
Name (Printed) <u>PATRICK HERES</u>		Name (Printed) <u>Sean C. Flynn</u>	

Beneficiary Approval*		Council or District Approval	
This service project will provide significant benefit, and we will do all we can to see it through. We realize funding on our part is not required, but we have informed the Scout of the financial support (if any) to which we have agreed. We understand any fund raising the Scout conducts will be in our name and that funds left over will come to us if we are allowed to accept them. We will provide receipts to donors as required.		I have read topics 9.0.2.0 through 9.0.2.15, regarding the Eagle Scout service project, in the <i>Guide to Advancement</i> , No. 33088. I agree on my honor to apply the procedures as written, and in compliance with the policy on "Unauthorized Changes to Advancement." Accordingly, I approve this proposal. I will encourage the candidate to prepare a project plan and share it with the designated project coach.	
<p>Our Eagle Candidate has provided us a copy of "Navigating the Eagle Scout Service Project, Information for Project Beneficiaries."</p> <p>Yes <input type="checkbox"/> No <input type="checkbox"/></p>			
Signed	Date	Signed	Date
Name (Printed)		Name (Printed)	

* While it makes sense to obtain approvals in the order they appear, there shall be no required sequence for the order of obtaining those approvals marked with an asterisk (*). Council or district approval, however, must come after the others.

Air Kit™ Prime

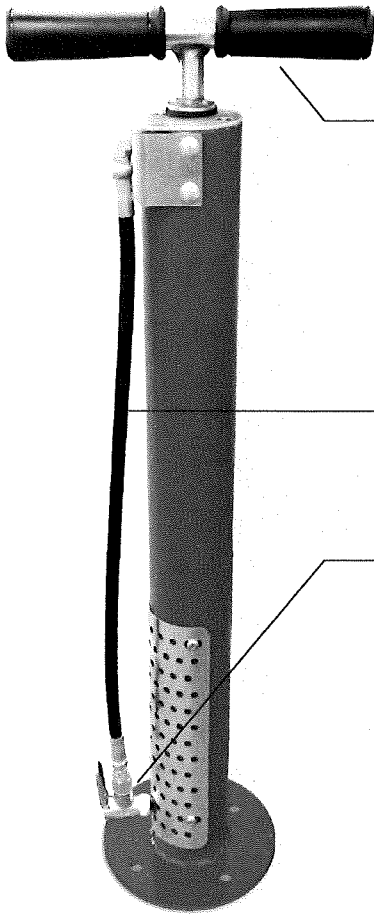

Durable rubber hand grips

Gasket rating -30° to 110° F

25" Reinforced air hose

Aluminum pump head accepts schrader and presta valves



Tamper-resistant fasteners included!

Air Kits require occasional maintenance and replacing of parts to remain serviceable. An extra gasket kit for the pump head is included with each unit shipped.

The Air Kit Prime includes Dero's aluminum Metal Head™ pump head.

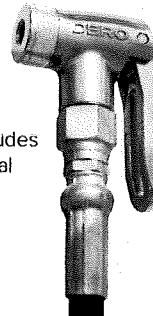

FINISH OPTIONS

Galvanized

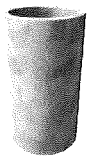

Stainless

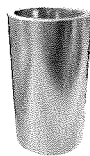

Powder Coat

White	Black	Light Gray RAL 7042	Deep Red RAL 3003	Yellow RAL 1023
CNH Bright Yellow	Orange RAL 2004	Beige RAL 1001	Iron Gray RAL 7011	Hunter Green RAL 6005
Light Green RAL 6018	Green RAL 6016	Sepia Brown RAL 8014	Bronze	Silver RAL 9007
Dark Purple	Flat Black	Wine Red RAL 3005		



1

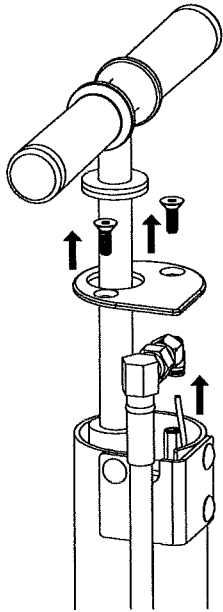

Remove the two tamper-proof screws at the top of the pump and lift the cap. Then disconnect the air line via the push-to-connect fitting at the top of the hose.

2

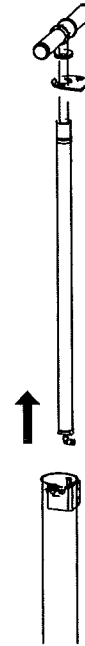

Slide the pump sideways out of the main body slot and then lift the whole pump and air lines out of the main body.

3

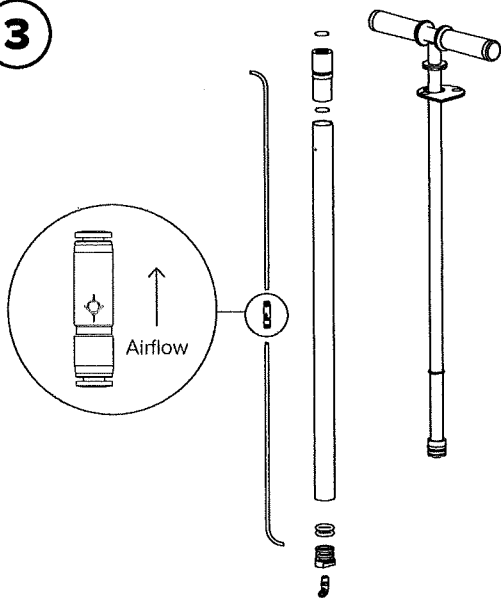

The pump can now be taken apart without tools for servicing.

4

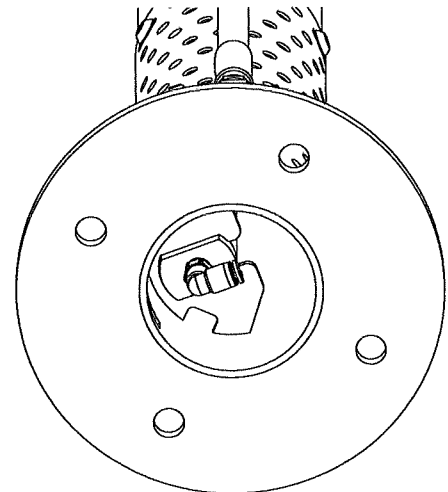

It may be necessary to gain access to the bottom of the main body to align the pump when re-assembling.

TOOLS NEEDED

Marker or Pencil
 Masonry Drill Bit 3/8"
 Drill (Hammer drill recommended)
 Hammer
 Wrench 9/16"
 Level

RECOMMENDED BASE MATERIAL

Solid concrete is the best base material for installation. To ensure the proper anchors are shipped with your Air Kit, ask your Dero representative which anchor is appropriate for your application. Be sure nothing is underneath the base material that could be damaged by drilling.

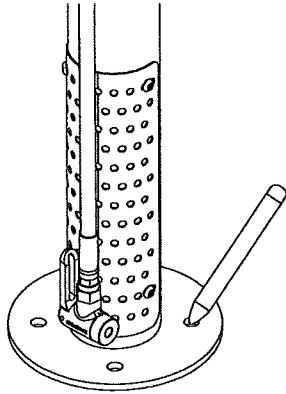
1

Place the Air Kit Prime in the desired location. Use a marker or pencil to outline the holes of the flange onto the base material.

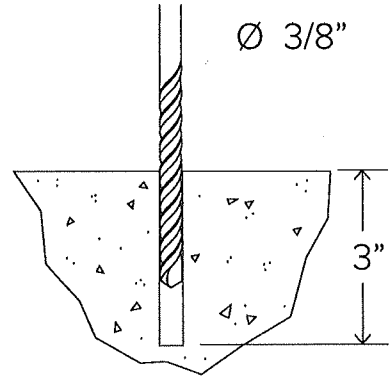
2

Drill 3/8" diameter holes 3" deep into surface. Make sure the holes are at least 3" away from any cracks in the base material.

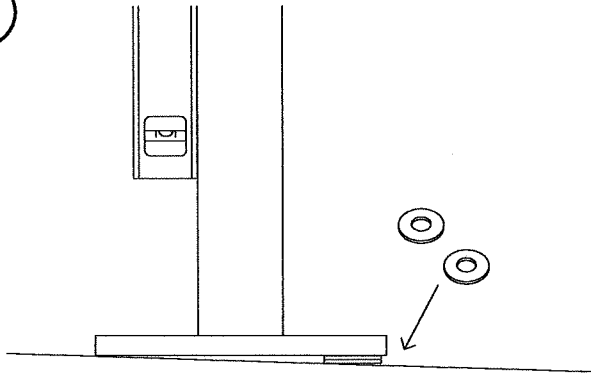
3

Use washers to level pump if necessary.

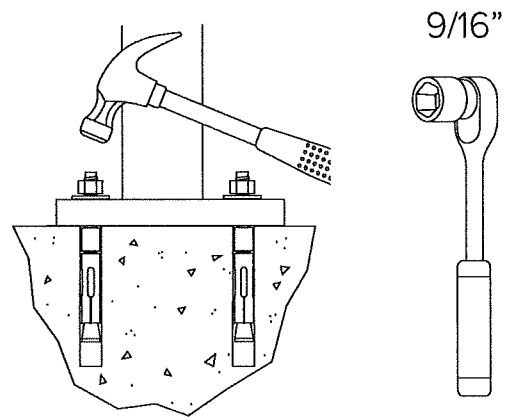
4

Thread nuts onto anchors, leaving approximately 1/4" of the anchor protruding, and tap into surface. **Place the 2 provided tamper-proof penta nuts on opposite sides.** Tighten nuts down to secure pump.



Be sure to save your tamper-resistant tools for any future maintenance. They are costly to replace.



Because public pumps require occasional maintenance, a spare pump head gasket kit is included with each unit shipped. Save this kit for future use.

Remove Metal Head™ by turning counter-clockwise.
You will need a 3/4" wrench. Replace with new
Metal Head and tighten.

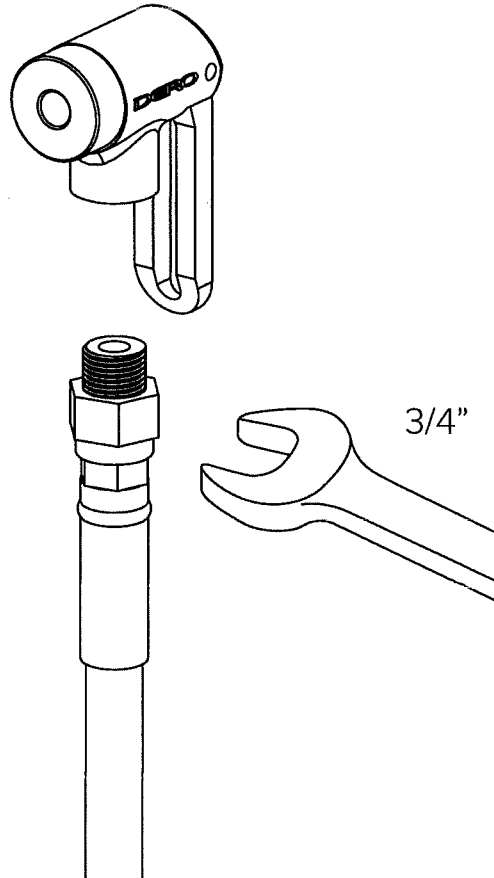

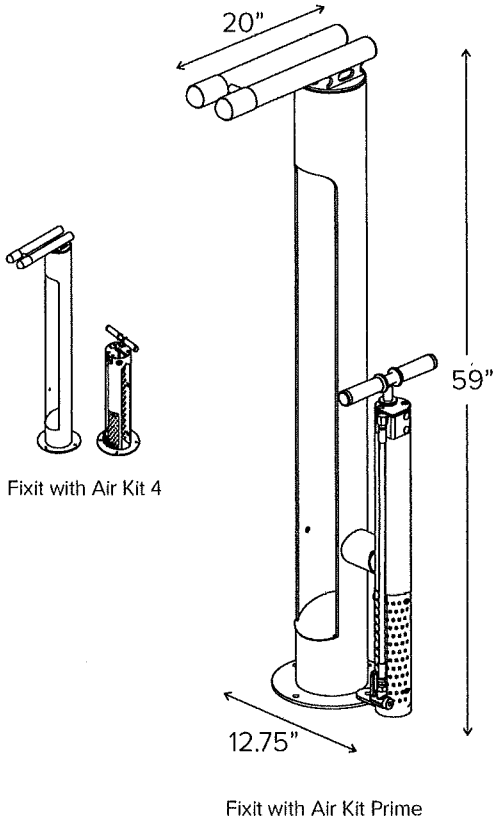

CAPACITY 1 Bike

MATERIALS

- Main body:** 6" x .154" tube
- Bike Hanger:** 1.5" sch. 40 pipe, 1/4" plate
- Foot:** 10" dia. x .25" plate
- Tool tethers:** 5/32" stainless steel cable
- Manual air pump**
- Hand tools:**
 - Phillips and flat head screwdrivers
 - 2.5, 3, 4, 5, 6, 8mm Allen wrenches
 - Headset wrench
 - Pedal wrench
 - 8, 9, 10, 11mm box wrenches
 - Tire levers (2)

FINISHES

- Galvanized**
An after fabrication hot dipped galvanized finish is our standard option.
- Powder Coat**
Our powder coat finish assures a high level of adhesion and durability by following these steps:
 1. Sandblast
 2. Epoxy primer electrostatically applied
 3. Final thick TGIC polyester powder coat
- Stainless**
Stainless Steel: 304 grade stainless steel material finished in either a high polished shine or a satin finish.

MOUNT OPTIONS

- Surface only**
Fixit has 10" diameter x.25" foot with four anchors per foot. Tamper-resistant fasteners are included.

PUMP OPTIONS

- No Pump**
- Air Kit Prime**
 - Attached to Fixit
 - Separate
- Air Kit 4**

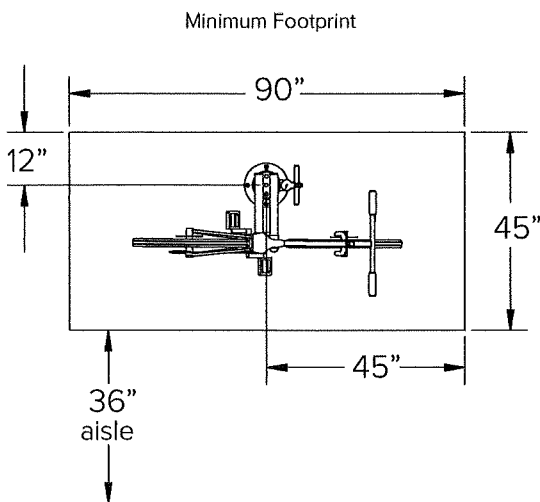

An optional wheel catch is available to hold bikes with no kick stands

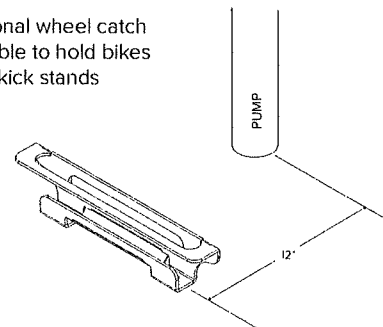

The Air Kit Prime should be installed at least 36" away from any obstructions.

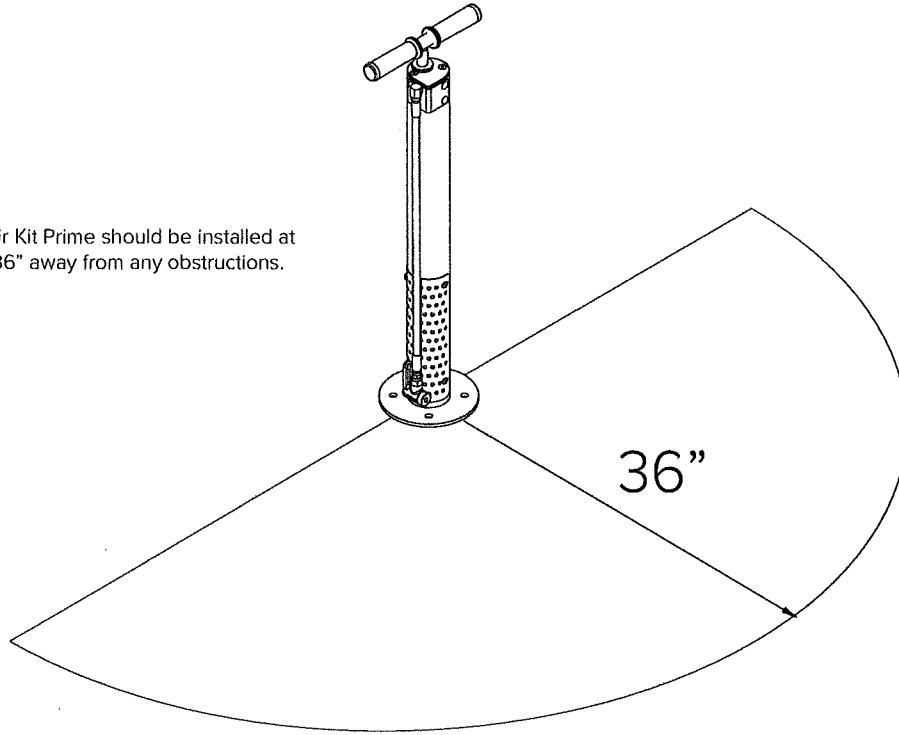

**APPLICATION FOR ALCOHOL SALE PERMIT ON PRIVATE PROPERTY
BOARD OF SELECTMEN**

I hereby apply for a permit to sell alcoholic beverages in a privately owned building in the Town of Boxford.

I understand and accept the provisions of Massachusetts General Laws Chapter 138, regarding the prohibition of distribution of alcoholic beverages to minors (any individual under the age of 21), and to intoxicated persons. The person identified below is to be in charge of the event, and will make sure that alcoholic beverages are not distributed contrary to the above referenced chapter. Issuance of this permit is contingent upon receipt by the Board of Selectmen of a liquor liability insurance policy which names the Town as an additional insured.

Tent located at i Farm
Building where event will be held

Auction Fundraiser
Type of function to be held

Thursday, June 8, 2023
Date of event

6PM - 10PM
Time of event

Harmony Wilson
Individual in charge of event

I hereby make application to the Board of Selectmen for a permit to distribute alcoholic beverages according to the terms of the agreement as stated above.

Harmony Wilson
Person making application

4/5/23
Date

Sales Manager, Vinwood + Board Member of Mersohawke
Title

-Do Not Write Below This Line-

Action of Board of Selectmen

___ Application granted ___ Date

Fee Collected: _____

Insurance Certificate Received () Yes () No

TIPS Server Verified () Yes () No

___ Application denied ___ Date

Authorized representative of Board of Selectmen

Date

ALCOHOL SALE PERMIT ON PRIVATE PROPERTY

Date Approved: _____

The Board of Selectmen is empowered through Massachusetts General Laws Chapter 138, Section 14 to issue "Special Liquor Licenses" to qualified applicants. Such licenses are generally issued for a specific event and for a fixed amount of time, usually one day or less. The Board of Selectmen may grant such a license after receiving an "application for license," submitted by the individual responsible for the management of liquor at that event. For-profit organizations may only be issued beer and wine licenses, while non-profit groups may be issued full licenses at the sole discretion of the Board of Selectmen.

The procedure to be observed by the applicant is as follows:

- 1) Submission of completed application for license to the Board of Selectmen and a copy to the Police Chief. Said license application shall specify the exact location, date, and time of the planned event. An approximate number of attendees will also be listed. The individual in charge of the management of the liquor distribution must be identified. The application shall be submitted to the Board of Selectmen at least ten business days prior to the event.
- 2) No special licensee shall sell any alcoholic beverages other than those purchased from a licensed wholesaler. The hours of operation shall be established by the Board of Selectmen, provided, however, that no special licensee shall sell or deliver any alcoholic beverage between the hours of 2:00 a.m. and 8:00 a.m. The special license shall be subject to such other terms and conditions as the Board of Selectmen deem necessary to protect public health, safety and welfare.
- 3) The Board of Selectmen requires that any server of alcohol licensed in the Town of Boxford pursuant to this policy will be TIPS Certified (T.I.P.S. - *Training and Intervention Procedures for Servers of alcohol*).
- 4) Submission of proof of Liquor Liability insurance in the minimum amount of \$1,000,000 and such other insurance as may be required by the Board of Selectmen, which names the Town as an additional insured to the Board of Selectmen.
- 5) The manager of the event will sign a statement that they understand and will comply with the provisions of M.G.L. Chapter 138 as they relate to the sale of alcoholic beverages to minors, and to intoxicated persons.
- 6) The Selectmen shall determine the fees to be charged. Unless otherwise voted by the Selectmen, the fee for a temporary license shall be \$50.00 per event, per day.
- 7) A completed permit shall be prepared by the Selectmen's office and signed by the Board. A copy shall be sent to the Chief of Police who will determine the need for police coverage for the event and will so inform the Selectmen. If police coverage is required, such coverage shall be paid for by the applicant. The original permit will be sent to the applicant, who will have it in their possession during the event.

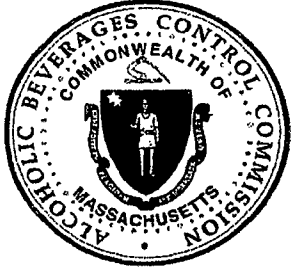

Commonwealth of Massachusetts
Office of the State Treasurer
Alcoholic Beverages Control Commission

CATERER'S LICENSE

M.G.L. c. 138, § 12C

This License permits the following licensee to: (a) to sell and serve alcoholic beverages to be served and drunk on the premises where the licensee caters a private event that is not open to the public; and (b) to store, transport, sell and deliver alcoholic beverages in the ordinary course of the licensee's business:

Vinwood Food Services, Inc.

3 Union Street
Ipswich, MA 01938

Approved by the Alcoholic Beverages Control Commission on September 08, 2022.

Jean Lorizio, Chairman

Crystal Matthews, Commissioner

Deborah Baglio, Commissioner

License Number: **CR-LIC-000002**
Record Number: **2022-000021-CR-REN**

THIS LICENSE WILL EXPIRE DECEMBER 31, 2023 UNLESS REVOKED OR CANCELLED DURING THIS PERIOD

THIS LICENSE SHALL BE DISPLAYED ON THE PREMISES IN A CONSPICUOUS PLACE WHERE IT CAN BE EASILY READ

This is your official TIPS certification card. Carry it with you as proof of your TIPS certification.

Congratulations!

This card certifies that you have successfully completed the TIPS (Training for Intervention ProcedureS) program. We value your participation and dedication to the responsible sale, service, and consumption of alcohol.

By using the techniques you have learned, you will help to provide a safer environment for your patrons, peers, and colleagues and reduce the tragedies resulting from intoxication, underage drinking, and drunk driving.

If you have any information you think would enhance the TIPS program, or if we can assist you in any way, please contact us at 800-438-8477.



Sincerely,

A handwritten signature in black ink that reads "Adam Chafetz".

Adam F. Chafetz
HCI President

ID#: 5453001 Name: Duane L Kristensen
Exam Date: 4/12/2021 Expiration Date: 4/12/2024



eTIPS On Premise 3.1

Issued: 4/12/2021
ID#: 5453001

CERTIFIED

Expires: 4/12/2024

Duane L Kristensen
Vinwood Caterers
3 Union St
Ipswich, MA 01938-2221

For service visit us online at www.gettips.com



CERTIFICATE OF LIABILITY INSURANCE

DATE (MM/DD/YYYY)
04/12/2023

THIS CERTIFICATE IS ISSUED AS A MATTER OF INFORMATION ONLY AND CONFERS NO RIGHTS UPON THE CERTIFICATE HOLDER. THIS CERTIFICATE DOES NOT AFFIRMATIVELY OR NEGATIVELY AMEND, EXTEND OR ALTER THE COVERAGE AFFORDED BY THE POLICIES BELOW. THIS CERTIFICATE OF INSURANCE DOES NOT CONSTITUTE A CONTRACT BETWEEN THE ISSUING INSURER(S), AUTHORIZED REPRESENTATIVE OR PRODUCER, AND THE CERTIFICATE HOLDER.

IMPORTANT: If the certificate holder is an ADDITIONAL INSURED, the policy(ies) must have ADDITIONAL INSURED provisions or be endorsed. If SUBROGATION IS WAIVED, subject to the terms and conditions of the policy, certain policies may require an endorsement. A statement on this certificate does not confer rights to the certificate holder in lieu of such endorsement(s).

PRODUCER Nicholas A Consoles Insurance Agency Inc 200 Lake St Suite 201B Peabody, MA 01960	CONTACT NAME: Judy Getchell PHONE (A/C, No, Ext): 978-223-4037 E-MAIL ADDRESS: judy@consolesinsurance.com	FAX (A/C, No): 978-656-6389
	INSURER(S) AFFORDING COVERAGE	
INSURED Vinwood Food Services, Inc. DBA Vinwood Caterers 3 Union Street Ipswich MA 01938	INSURER A : Norfolk & Dedham Mutual Fire Insurance Company	
	INSURER B : United States Liability Insurance Company	
	INSURER C :	
	INSURER D :	
	INSURER E :	
	INSURER F :	

COVERAGES **CERTIFICATE NUMBER:** **REVISION NUMBER:**

THIS IS TO CERTIFY THAT THE POLICIES OF INSURANCE LISTED BELOW HAVE BEEN ISSUED TO THE INSURED NAMED ABOVE FOR THE POLICY PERIOD INDICATED. NOTWITHSTANDING ANY REQUIREMENT, TERM OR CONDITION OF ANY CONTRACT OR OTHER DOCUMENT WITH RESPECT TO WHICH THIS CERTIFICATE MAY BE ISSUED OR MAY PERTAIN, THE INSURANCE AFFORDED BY THE POLICIES DESCRIBED HEREIN IS SUBJECT TO ALL THE TERMS, EXCLUSIONS AND CONDITIONS OF SUCH POLICIES. LIMITS SHOWN MAY HAVE BEEN REDUCED BY PAID CLAIMS.

INSR LTR	TYPE OF INSURANCE	ADDL SUBR INSD WVD	POLICY NUMBER	POLICY EFF (MM/DD/YYYY)	POLICY EXP (MM/DD/YYYY)	LIMITS
A	<input checked="" type="checkbox"/> COMMERCIAL GENERAL LIABILITY CLAIMS-MADE <input checked="" type="checkbox"/> OCCUR GEN'L AGGREGATE LIMIT APPLIES PER: <input checked="" type="checkbox"/> POLICY <input type="checkbox"/> PRO-JECT <input type="checkbox"/> LOC OTHER:		P012212535	04/13/2023	04/13/2024	EACH OCCURRENCE \$ 1,000,000 DAMAGE TO RENTED PREMISES (Ea occurrence) \$ 300,000 MED EXP (Any one person) \$ 5,000 PERSONAL & ADV INJURY \$ 1,000,000 GENERAL AGGREGATE \$ 2,000,000 PRODUCTS - COM/OP AGG \$ 2,000,000
A	AUTOMOBILE LIABILITY ANY AUTO <input checked="" type="checkbox"/> OWNED AUTOS ONLY <input checked="" type="checkbox"/> SCHEDULED AUTOS <input checked="" type="checkbox"/> HIRED AUTOS ONLY <input checked="" type="checkbox"/> NON-OWNED AUTOS ONLY		92282046A	04/13/2023	04/13/2024	COMBINED SINGLE LIMIT (Ea accident) \$ 1,000,000 BODILY INJURY (Per person) \$ BODILY INJURY (Per accident) \$ PROPERTY DAMAGE (Per accident) \$
B	<input checked="" type="checkbox"/> UMBRELLA LIAB <input checked="" type="checkbox"/> OCCUR <input type="checkbox"/> EXCESS LIAB <input type="checkbox"/> CLAIMS-MADE <input checked="" type="checkbox"/> DED <input checked="" type="checkbox"/> RETENTION \$ 5000		U2207035A	04/13/2023	04/13/2024	EACH OCCURRENCE \$ 1,000,000 AGGREGATE \$ 1,000,000
	WORKERS COMPENSATION AND EMPLOYERS' LIABILITY ANY PROPRIETOR/PARTNER/EXECUTIVE OFFICER/MEMBER EXCLUDED? (Mandatory in NH) If yes, describe under DESCRIPTION OF OPERATIONS below	<input type="checkbox"/> Y / <input type="checkbox"/> N N/A				PER STATUTE OTH-ER E.L. EACH ACCIDENT \$ E.L. DISEASE - EA EMPLOYEE \$ E.L. DISEASE - POLICY LIMIT \$
C	Liquor Law Liability		LQ1003815B	04/13/2023	04/13/2024	Liquor Liability Limit \$1,000,000 Liquor Limit-Aggregate \$2,000,000

DESCRIPTION OF OPERATIONS / LOCATIONS / VEHICLES (ACORD 101, Additional Remarks Schedule, may be attached if more space is required)

CERTIFICATE HOLDER Vinwood Food Services, Inc. 3 Union Street Ipswich, MA 01938	CANCELLATION SHOULD ANY OF THE ABOVE DESCRIBED POLICIES BE CANCELLED BEFORE THE EXPIRATION DATE THEREOF, NOTICE WILL BE DELIVERED IN ACCORDANCE WITH THE POLICY PROVISIONS. AUTHORIZED REPRESENTATIVE 
---	---

From: [James Riter](#)
To: [Leanne Mihalchik](#)
Subject: Re: IFarm Event - alcohol permit
Date: Thursday, April 20, 2023 1:01:15 PM

I have no concerns with the Ifarm event. They have had a number of permits in the past and there has never been an issue.

Jim

Sent from my Verizon, Samsung Galaxy smartphone
Get [Outlook for Android](#)

From: Leanne Mihalchik <LMihalchik@town.boxford.ma.us>
Sent: Thursday, April 20, 2023 12:37:46 PM
To: James Riter <JRiter@town.boxford.ma.us>
Subject: IFarm Event - alcohol permit

Hi Chief

iFarm is having an event on June 8 and has applied for an alcohol permit. Do you have any issue with issuing this permit?

Thanks!
Leanne

Leanne Mihalchik

Administrative Services Manager/HR Coordinator
Town of Boxford
7A Spofford Road
Boxford, MA 01921
Phone: 978-887-6000 x111
Fax: 978-887-0758

This email is subject to MGL c66s10, Public Records Law

MIIA HEALTH BENEFITS TRUST
Boxford
Renewal Proposal
07/01/2023 - 06/30/2024

MONTHLY CONTRIBUTION RATES						
PRODUCTS		Current		Renewal		
Unified Plan Name for FY2024	COVERAGE	RATES	RATES	CHANGE	BUNDLED RATES*	BUNDLED CHANGE*
Blue Care Elect \$250 Deductible with HCCS	Individual	\$ 1,058.36	\$ 1,152.55	8.90%	\$ 1,146.79	8.36%
	Family	\$ 2,831.89	\$ 3,083.93		\$ 3,068.51	
Network Blue NE \$250 Deductible with HCCS	Individual	\$ 895.33	\$ 975.01	8.90%	\$ 970.13	8.36%
	Family	\$ 2,391.94	\$ 2,604.82		\$ 2,591.80	
Network Blue Select \$250 Deductible	Individual	\$ 832.67	\$ 906.78	8.90%	\$ 902.25	8.36%
	Family	\$ 2,224.50	\$ 2,422.48		\$ 2,410.37	
New -Dental Blue Freedom Plan (High) - 100/80/50; \$50/\$150 Ded.; \$1,000 CYM	Individual		\$ 44.28		\$ 44.28	
	Family		\$ 92.12		\$ 92.12	
New - Dental Blue Freedom Plan Enhanced Value (Low) \$1,500 Plan	Individual		\$ 35.10		\$ 35.10	
	Family		\$ 87.30		\$ 87.30	

Renewal rates are based on final plan design and enrollment.

Senior plans will renew on January 1, 2024.

Please provide a copy of the in-force PEC or IAC agreement, if applicable.

*Medical rates reduced by 0.5% due to Medical coverage alongside Dental and Vision coverage.

Signed commitment is due on or before April 1, 2023.

Renewal rates are based on continuing the current enrollment level.

Signature for Acceptance of Rates	Title	Date
Print Name		

**Memorandum of Agreement
Between
Boxford Communications Dispatchers Association
&
Town of Boxford**

July 1, 2023 – June 30, 2026

Upon ratification, the following are agreed upon changes or additions to the existing agreement with an expiration date of June 30, 2026:

1. Throughout contract

Make entire contract gender neutral, including replacing “Board of Selectmen” with “Select Board”; “Chairman” with “Chair”, etc.

2. Article III: Persons Covered by this Agreement

Revise section as follows:

The Town recognizes the Association as the exclusive representative, for the purpose of collective bargaining relative to wages, hours of work and other conditions of employment, of all employees of the Boxford Communications Department, ***except the Director of Communications***. ~~and the Police Secretary, who are employed by various Town Departments.~~
The Town and the Association agree not to discriminate against employees covered by this Agreement on account of membership or non-membership in the Association. The Municipal Employer and the Association agree not to discriminate in any way against employees covered by this agreement or other present or prospective employees on account of race, religion, creed, color, national origin, sex or age.

3. Article VII Grievance (page 6)

Step 1 change from “48 hours” to “2 business days”

Rest of steps: change from “days” to “business days”

Step 2 change from “5 days’ to “5 business days”; 7 days to “7 business days”

Add “Nothing contained herein shall be construed to authorize any arbitrator to alter or modify this agreement or any of its provisions or take any action to prevent the Town and the Association from settling by mutual agreement.”

4. Article VIII Holidays (page 7)

New Section 1

Members shall be entitled to the following twelve (12) paid holidays: New Year's Day, Martin Luther King, Jr. Day, Washington's Birthday, Patriots' Day, Memorial Day, Juneteenth, Independence Day, Labor Day, Columbus Day, Veterans' Day, Thanksgiving Day, Christmas Day

5. Article XI Overtime and Extra Hours

Section 3 Extra Emergency Hours p10: Make gender neutral (Director his discretion Section) 3 Extra Emergency Hours page 10

Add new Section 7 Compensatory Time:

Employees may accept compensatory time off, at 1.5 times the hours actually worked, in lieu of compensation of overtime services, at the discretion of the Communications Director. An employee cannot earn or carry more than 72 hours of compensation time in a fiscal year. Starting July 1, 2023, this paragraph shall be phased into use during the three-year contract expiring June 30, 2026. Employees shall be in compliance with the 72 hours of compensation time as of June 30, 2025. Compensation time not used during a fiscal year will be paid out at the last pay period in June of each fiscal year as of June 30, 2025. Compensatory time thereafter is capped at 72 hours earned or used per year must be taken within the fiscal year or it shall be paid as overtime worked during the last pay period of each fiscal year.

6. Article XII Sick Leave

New first sentence "Employees shall follow the Town's Personnel Bylaw for Sick Leave, Chapter 23, Section 6D, with the exception of the following:"

Section 2 delete last sentence "As this section applies to the Police Secretary, he/ she shall be required to give notice to the Chief of Police or his/her designee"

7. Article XIII Other Leaves of Absence

Replace Section (a) with

An eligible employee may exercise his/her right to take leave, either paid or unpaid, as afforded by state or federal law, but must do so in accordance with the parameters of relevant state or federal law. Said leave shall include, but is not limited to, family and medical paid and unpaid leave pursuant to the Family and Medical Leave Act of 1993 (FMLA) and small necessities unpaid leave pursuant to the Massachusetts Small Necessities Leave Act of 1998 (SNLA). Upon request of an employee, information pertaining to leave associated with this section will be provided by the office of the Select Board.

8. Article XVII Payment by the Town

Section 1, Hourly Wages

Parties agree to the following base wages:

Effective July 1, 2023 2%

Effective July 1, 2024 2%

Effective July 1, 2025 2%

FY23 – adjustment of \$1.00 per hour increase across all steps

FY24 – adjustment of \$0.25 per hour increase across all steps

FY25 – adjustment of \$0.50 per hour increase across all steps

Dispatcher Employees Hourly Rate

	FY24	FY25	FY26
Step 1	\$ 24.61	\$ 25.36	\$ 26.36
Step 2	\$ 25.21	\$ 25.97	\$ 26.99
Step 3	\$ 25.79	\$ 26.55	\$ 27.58
Step 4	\$ 26.45	\$ 27.23	\$ 28.27
Step 5	\$ 26.97	\$ 27.76	\$ 28.81

Remove Police Secretary Hourly Rate and last paragraph

Section 3 Compensation for Training

Delete 3rd paragraph (eliminate stipend):

Any employee successfully completing the required Emergency Management Dispatch training and actively employed at the commencement of the fiscal year shall be entitled to an annual five hundred dollar (\$500) stipend to be paid on or before August 1st of each fiscal year. Effective July 1, 2016, the stipend shall increase to an annual six hundred dollars (\$600).

9. Add new Section: Performance Evaluation

Members will participate in the Town’s Performance Evaluation process. Performance evaluations provide a way to let members know how they are doing and what will be expected

of them in the future. The Association and Director of Communications will work together in the first year of this contract to develop the performance evaluation tool. The Association will identify a small group of members to work with the Director of Communications. It is expected for performance evaluations to begin at the end of the first year of the contract. The Association and the Director of Communications also commit to reviewing the performance evaluation tool every 2 years.

Town of Boxford

Date: _____

Boxford Communications
Dispatchers Association

James Fernandez
Marguerite T. Decoteau

Date: April 21, 2023



MHP MBTA Communities Technical Assistance Program ("3A-TA")

- ① Program Overview
- ② Application & Community Details
- ③ Technical Assistance Request
- ④ Signature from Chief Elected Official

Municipal Contact Information

Municipality *

Community Transit Category *

Community Transit Categories for all MBTA communities are listed in Appendix 1 of the Final Guidelines.

Primary Contact Name *

Title *

Email *

Phone *

Address *

7A Spofford Road

Address Line 2

Boxford

Massachusetts 

01921

[< Back](#)

[Technical Assistance Request >](#)



MHP MBTA Communities Technical Assistance Program ("3A-TA")

- ① Program Overview ② Application & Community Details ③ Technical Assistance Request
- ④ Signature from Chief Elected Official

Technical Assistance Request

Compliance Readiness *

Municipality has not started planning for compliance
▼

Select the statement that most accurately describes the community's status relative to compliance.

Municipal Capacity *

Municipality has no capacity to pursue compliance

Select the statement that most closely reflects the municipality's capacity to obtain compliance with Section 3A.

Type of Technical Assistance Requested *

- Locating/Delineating Districts
- Developing Use and Intensity Requirements
- Calculating Capacity and Gross Density Requirements
- Drafting Zoning Amendment
- Other

Other

Check all that apply

Technical Assistance Request Narrative *

Boxford has submitted an Interim Action Plan and has received confirmation of Interim Compliance. The proposed dates for various compliance related activities are presented in the Interim Action Plan. The Land Use Department in Boxford consists of one employee with a shared secretary, and relies heavily on MVPC for technical assistance. This grant is needed to fund MVPC's support for Boxford's MBTA Communities Act compliance effort.

Describe the municipality's current compliance status; work done to date to prepare for compliance including community education; the type (s) of technical assistance needed, and a general compliance timeline, including target zoning adoption dates.

Proposed District(s) Boundaries (if available)

Upload or drag files here.



[MIMAP w blue dots.pdf](#)
0.3 MB



If available, provide a map or maps showing existing or proposed district boundaries

DHCD Approved Action Plan (required) and any other supporting material (optional)

Upload or drag files here.



[Boxford - AP - 1-25-23 with revision.pdf](#)
0.7 MB



Provide links to documents that would support request for assistance, including a completed [DHCD Action Plan](#)

[< Back](#)

[Next >](#)



MHP MBTA Communities Technical Assistance Program ("3A-TA")

- ① Program Overview
- ② Application & Community Details
- ③ Technical Assistance Request
- ④ Signature from Chief Elected Official

Chief Elected Official or Alternate Authorized Signatory *

First	Last
-------	------

Please include a signature from Chief Elected Official or other individual authorized to sign on behalf of the municipality.

Title *

Signature *

×

draw type

Please include CEO or Alternate Si

Optional PDF of Signature (if unable to sign on Form)

or drag files here.

[< Back](#)

[Submit Application](#)

[Update](#)

[Action](#)



TOWN OF BOXFORD

Office of the Select Board
7A Spofford Road
Boxford, MA 01921
978-887-6000
www.boxfordma.gov

DATE: April 20, 2023

TO: Matthew Coogan
Town Administrator

FROM: Leanne Mihalchik
Administrative Services Manager/HR Coordinator

SUBJECT: Surplus Equipment

Please declare the aged technology items as presented on the attached list as surplus to be disposed of according the Town of Boxford's "Disposition of Surplus" policy. Policy attached.

"I move to declare the aged technology components itemized on the attached surplus list dated March 30, 2023, as surplus goods to be disposed of as separate items in accordance with the Town's policy for "Disposition of Surplus Property with an estimated net value of less than \$5000 each"

TOWN OF BOXFORD

DISPOSITION OF SURPLUS PROPERTY

SUBJECT TO M.G.L. c 30B

WITH AN ESTIMATED NET VALUE OF LESS THAN \$5,000

Section 1. Pursuant to M.G.L. c. 30B, §15(f), the Town's Disposition Agent, as defined below, is required to dispose of all tangible supplies that are no longer useful to the Town but have a resale or salvage value of less than \$5,000 using written procedures approved by the Board of Selectmen. This procedure applies to all tangible supplies, including motor vehicles, machinery, computer equipment, furniture, and other supplies. The term "supplies" does not include real property.

Prior to a disposition under this procedure, a supply must be declared to be no longer useful to the Town and must have an estimated net value of less than \$5,000.

Section 2. Property shall be declared surplus by the Town's Disposition Agent, Matthew Coogan who is authorized to declare a supply surplus.

Having been so declared and approved for disposition, the following procedures with respect to the property shall be followed by the Disposition Agent, who is responsible for assuring compliance with these procedures:

Value the Supply: The Disposition Agent shall value the property in a commercially reasonable manner. Valuations shall be aggregated where property is to be sold in a single lot. If a valuation is \$5,000 or more, the Disposition Agent must meet the requirements of M.G.L. c.30B, §15(b) through (d).

Offer the Property to Other Departments: The Disposition Agent shall circulate a list of the property to be disposed of to other Town departments and shall convey the property to any department that wants it.

Dispose of the Property: If the property is valued at less than \$5,000 and no department is interested in the property, the Disposition Agent shall:

- Prepare a complete list of the property to be disposed of and submit to the Board of Selectmen for prior approval;
- Ensure the property is in the best possible condition;
- Establish a procedure for potential buyers to examine the property;
- Advertise the pending sale by posting on website or soliciting quotes.
- Convey the property to the responsive person making the best offer via submittal to the Selectmen's Office by deadline on advertisement; and
- Properly record all documents.

DISPOSITION OF SURPLUS PROPERTY
Page 2

Section 3: The Town of Boxford shall reserve the right to accept or reject all offers, and to sell any property to any person offering to pay more than the highest offer received as provided in M.G.L. c.30B, §15(d)(1). All property shall be sold on an "as is" basis, with no warranty of any kind, express or implied.

Section 4. All monies from the disposition of supplies under this procedure shall be payable to the Town of Boxford. All revenue from the disposal of supplies under this procedure shall be deposited with the Town Treasurer for deposit in the general fund or appropriate revolving or enterprise fund, as recommended by the department head and approved by the Treasurer.

Section 5. If the Town receives no offers for a surplus supply, it may be disposed of in any commercially reasonable manner.

This Policy for Disposition of Property valued at under \$5,000 was approved by the Board of Selectmen on this 19th day of March, 2012.

Peter C. Perkins, Chair

Charles J. Costello

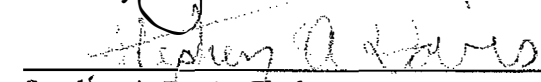
Stephen A. Davis, Clerk

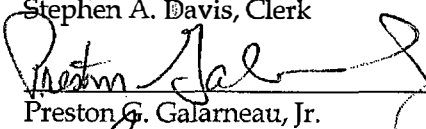
Preston G. Galarneau, Jr.

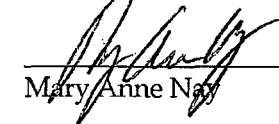
Mary Anne Nay

**BOARD OF SELECTMEN
TOWN OF BOXFORD**

ERRS PROPOSAL TO APPROVE 5% COLA FOR FY 2023

FACTS FOR CONSIDERATION

Ellen Guerin, Treasurer/ Collector

April 6, 2023

- On 12/19/22, ERRB voted (4-1) to approved 5% COLA for FY 2023. Requires ratification of 13 member units of ERRS.
- COLA is calculated on base pension of \$16,000 (which was increased from \$14,000 on 7/01/2022). 3% COLA is \$480/yr. 5% COLA is \$800/yr.
- The unfunded liability (UL) of ERRS is \$432M. The system is 60.3% funded, ranking it 81 out of 104 MA retirement systems. Like OPEB liability and funding, this is a consideration in credit rating of town debt issuances.
- Increasing the COLA base increases the UL by \$10.5M. Approving a 5% COLA will increase the UL by \$6M.
- Per attached funding schedule, the UL is on track to be fully funded in 2035 by increasing member unit contributions by 4.0-6.5% per year.
- Boxford's annual contributions are the ERRS assessments appropriated in the town budget. Recent payments and increases are:

Fiscal Year	Assessment	Increase
2021	\$1,423,044	
2022	\$1,523,087	7.0%
2023	\$1,551,592	1.9%
2024	\$1,742,530	12.3%

Section 2: Actuarial Valuation Results

Funding schedule

(1) Fiscal Year Ended June 30	(2) Employer Normal Cost	(3) Amortization of ERI (2002) Liability	(4) Amortization of ERI (2003) Liability	(5) Amortization of Remaining Liability	(6) Actuarially Determined Contribution (ADC): (2)+(3)+(4)+(5)	(7) Total UAL at Beginning of Fiscal Year	(8) Percent Increase in ADC Over Prior Year
2023	\$9,856,270	\$10,049	\$9,333	\$34,637,093	\$44,512,745	\$432,172,282	--
2024	10,165,422	10,501	9,753	37,220,397	47,406,073	425,341,913	6.50%
2025	10,484,183	10,974	10,191	39,982,120	50,487,468	415,268,350	6.50%
2026	10,812,848	11,468	10,650	42,934,187	53,769,153	401,533,620	6.50%
2027	11,151,722	11,984	11,129	46,089,313	57,264,148	383,677,727	6.50%
2028	11,501,123	12,523	11,630	49,461,042	60,986,318	361,194,872	6.50%
2029	11,861,372	0	0	53,089,057	64,950,429	333,529,354	6.50%
2030	12,232,806	0	0	55,315,640	67,548,446	300,071,118	4.00%
2031	12,615,768	0	0	57,634,616	70,250,384	261,888,361	4.00%
2032	13,010,614	0	0	60,049,785	73,060,399	218,551,507	4.00%
2033	13,417,709	0	0	62,565,106	75,982,815	169,596,843	4.00%
2034	13,837,432	0	0	65,184,696	79,022,128	114,523,959	4.00%
2035	14,270,171	0	0	52,793,011	67,063,182	52,793,011	-15.13%
2036	14,716,326	0	0	0	14,716,326	0	-78.06%

Notes:

Fiscal 2023 Actuarially Determined Contribution set equal to budgeted amount

Actuarially Determined Contributions are assumed to be paid on July 1

Item (2) reflects 2.75% growth in payroll, plus an additional 0.15% adjustment to total normal cost to reflect the effects of mortality improvement due to generational mortality assumption

Projected normal cost does not reflect the impact of pension reform for future hires

Projected unfunded actuarial accrued liability does not reflect the recognition of deferred investment gains/losses

ESSEX REGIONAL RETIREMENT SYSTEM

491 Maple Street, Suite 202, Danvers MA 01923

Telephone: 978-739-9151

Email: info@essexrrs.org

www.essexregional.com

Charles E. Kostro
Executive Director

Board Members:

Andrew J. Sheehan
Kevin A. Merz
Katherine E. Carleton
Susan J. Yaskell
Vincent R. Malgeri

January 18, 2023

Matthew Coogan
Town Administrator
Town Hall
7A Spofford Road
Boxford, MA 01921

Dear Mr. Coogan:

On November 16, 2022, the Governor signed into law Chapter 269 of the Acts of 2022. This act provides that retirement boards may increase the Cost-of-Living Adjustment (“COLA”) for Fiscal Year 2023 (“FY2023”) up to five percent on the base amount for eligible members of the Essex Regional Retirement System (“ERRS”). The COLA base amount for ERRS is \$16,000.

At their meeting on December 19, 2022, the Essex Regional Retirement Board (“Board”) voted four members in favor, and one opposed, to increase the COLA for FY2023 to five percent. This would add an additional two percent to the previously approved three percent increase approved by the Board at their meeting on April 25, 2022. The three percent increase in the COLA was effective as of July 1, 2022. The additional two percent increase in the COLA would be retroactive to that date.

However, the additional two percent increase in the COLA cannot take effect unless it is approved by two thirds of the select boards of the municipal units of ERRS. Enclosed please find a copy of the memo outlining this process which was distributed by the Public Employee Retirement Administration Commission (PERAC).

There are nineteen municipal units that are members of ERRS. Therefore, the increase in the COLA to five percent will not be effective unless it is approved by a majority vote of the select board in thirteen municipal units.

The Board respectfully requests that such a vote be taken, and the retirement system notified of the results, on or before April 1, 2023. Should thirteen municipal units approve this additional increase, receiving notice of the votes on or before April 1, 2023, will permit sufficient time for the additional COLA to be calculated and correctly applied to the benefit payments of eligible recipients. The application of this additional increase must be done within this fiscal year, which ends on June 30, 2023. Upon a vote of your Select Board, please submit a certified copy of the vote to ERRS.

If you have any questions regarding this notice, please do not hesitate to contact me at (978) 739-9151, extension 105, or via email at ckostro@essexrrs.org. You may also submit a copy of your certified board vote to me at this email address.

Thank you for your cooperation in this matter.

Sincerely,

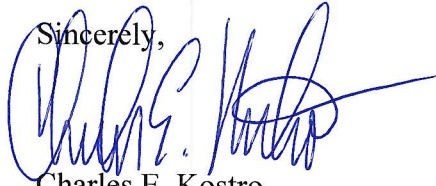

Charles E. Kostro
Executive Director

MEMORANDUM

TO: All Retirement Boards

FROM: John W. Parsons, Esq., Executive Director 

RE: 5% Local COLA option

DATE: November 18, 2022

On November 16, 2022, the Governor signed Chapter 269 of the Acts of 2022 into law. This act provides the local retirement systems with a local option to increase the Cost of Living Adjustment ("COLA") for Fiscal Year 2023 to up to 5 percent on the base amount specified pursuant to G.L. c. 32, § 103. The approval of the increase can occur at any time during the fiscal year and will take effect as of July 1, 2022.

The local approval mechanism is different than traditional COLA increases and COLA base increases. In order for a system to adopt a COLA increase pursuant to this act, **the retirement board must vote for the increased amount and then it must also receive local approval.**

For purposes of this act, local approval means:

- In a city, the mayor must recommend the increase to the city council and the council must vote in favor.
- In a city having a Plan D or Plan E charter, the city manager must recommend the increase to the city council and the council must vote in favor.
- In a town, the chief executive officer¹ - the select board in nearly all cases - must vote in favor to accept the increase rather than the town meeting as is the case for COLA base increases.
- In a district, or other political subdivision, the governing board, commission or committee must vote in favor to accept the COLA increase.

¹ As defined in G.L. c. 4, § 7, "chief executive officer", when used in connection with the operation of municipal governments shall include the mayor in a city and the select board in a town unless some other municipal office is designated to be the chief executive officer under the provisions of a local charter.



MEMORANDUM - Page Two

TO: All Retirement Boards
FROM: John W. Parsons, Esq., Executive Director
RE: 5% Local COLA option
DATE: November 18, 2022

- In a regional system, two-thirds of the cities and towns within the system must approve the increase. This is done in the same fashion as stated above for municipalities: in a city, by the city council upon recommendation by the mayor or, in a city with a Plan D or Plan E charter, the city manager; or, in a town, by approval of the chief executive officer (likely the select board) as defined by G.L. c. 4, § 7.
- In a county, the county commissioners, who normally do not have a role in COLAs nor COLA base increases, must vote to accept **and** two-thirds of the cities and towns within the system must approve the increase in the same manner as stated above for regional systems.

Though many local systems are comprised of multiple units such as housing authorities and districts, the two-thirds language only applies to regional and county systems as the approval specified in the statute only refers to cities and towns as voting political subdivisions.

Section 2 of the act provides that a COLA increase pursuant to this act is retroactive to July 1, 2022. Any COLA increase, in addition to any COLA previously adopted for FY 23, will become part of the fixed amount of a retirees' retirement allowance in the same manner as all COLAs granted pursuant to section 103.

PERAC has already received questions about estimating the cost of the enhanced COLA. PERAC Actuary John Boorack has provided the following formula for a conservative full-cost estimate, not a one-year estimate, to assist boards in their planning:

$$(0.2) \times (\text{COLA base}) \times (\# \text{ of retirees/beneficiaries})$$

If you have any questions about this memo, please contact PERAC's General Counsel, Judith Corrigan, at (617) 591-8904 or at judith.a.corrigan@mass.gov.